

Series 4000/7000

Flow Computer Installation Guide



Table of Contents

1.	The OMNI 4000/7000 Series.....	1-1
1.1	Users of the Guide	1-1
1.2	Certifications and Standards.....	1-1
1.2.1	IEC Test Procedure Compliance.....	1-2
1.2.2	Measurement Security and Firmware Downloads (WELMEC 7.2 Extension D)	1-3
1.3	Calculations	1-4
1.4	Equipment Overview.....	1-5
1.5	Safety.....	1-7
1.5.1	Basic Electric Safety.....	1-7
1.5.2	Electrical Grounding Requirements	1-7
1.5.3	Safety Labels.....	1-1
2.	OMNI 4000/7000 Overview	2-1
2.1	Hardware	2-1
2.2	Firmware	2-2
2.3	Software.....	2-2
3.	Installation.....	3-1
3.1	Installation Requirements	3-1
3.2	Equipment Verification	3-2
3.3	Documentation Review	3-3
3.4	Mount the OMNI 4000/7000 Flow Computer.....	3-3
3.4.1	Panel Mount	3-5
3.4.2	Panel Mount with Extended Back Panel.....	3-6
3.4.3	NEMA Mount	3-10
3.4.4	NEMA 4X Enclosure Installation	3-15
3.4.5	Optional Digital I/O Terminal Installation.....	3-16
3.5	OMNI 4000/7000 Back Panel Terminal Blocks	3-17
3.6	Input and Output Modules Overview	3-18
3.7	Connect to Field Devices.....	3-20
3.7.1	Digital I/O Multiplexer	3-20
3.7.2	Digital I/O Terminal Board.....	3-22
3.7.3	Dual Ethernet Module.....	3-25
3.7.4	Serial Module	3-26
3.7.5	Process I/O Modules	3-30
3.8	Power the Flow Computer	3-38
3.8.1	AC Power	3-38

3.8.2	DC Power	3-39
4.	Configuration.....	4-1
4.1	Getting Started.....	4-1
4.1.1	Front Panel Navigation.....	4-1
4.1.2	User Logon.....	4-4
4.1.3	Set the Date and Time	4-5
4.2	Check Modules	4-6
4.3	Configuring Communication Ports (Front Panel).....	4-7
4.3.1	Configuring Serial Ports	4-8
4.3.2	Configuring Ethernet Ports.....	4-10
4.3.3	Communicate using a USB Port	4-12
4.4	Software Installation.....	4-13
4.5	OMNICONNECT™ License Activation	4-14
4.5.1	Welcome Email	4-14
4.5.2	Online Activation	4-15
4.5.3	Manual Activation.....	4-16
4.5.4	Phone Activation	4-18
4.5.5	30-Day and 60-Day Trial	4-20
4.6	Firmware License Activation.....	4-21
4.6.1	Welcome Email	4-21
4.6.2	Online Activation	4-22
4.6.3	Manual Activation.....	4-24
4.6.4	Code Activation	4-27
4.6.5	Update the CPU.....	4-29
4.7	Configure OMNICONNECT™ Connection	4-30
4.7.1	Startup Screen	4-30
4.7.2	Setup Sites	4-34
4.7.3	Setup Preferences.....	4-40
4.7.4	Connect to the Flow Computer	4-41
4.8	Security Setup.....	4-43
4.8.1	Administrator Functions.....	4-44
4.8.2	User Security.....	4-44
4.8.3	User Permissions Guidelines	4-46
4.8.4	Port Security.....	4-48
4.8.5	Port Permissions Guidelines	4-49
4.8.6	Import and Export Functions	4-50
4.8.7	User Password Rules.....	4-52
4.9	Check for Updates	4-53

4.10	Configure the OMNI 4000/7000.....	4-54
4.10.1	General Setup	4-54
4.10.2	Setup the Equipment List	4-55
4.10.3	Configure Input and Output Channels.....	4-56
4.10.4	Configure Ports	4-61
4.10.5	Assign I/O to a Meter Run.....	4-63
4.10.6	Configure Products.....	4-68
4.10.7	Configure Provers	4-70
4.10.8	Configure a Printer	4-71
4.10.9	Configure Report Setup	4-73
4.10.10	Configure Batch	4-74
4.10.11	Peer to Peer Protocol	4-74
5.	Calibration.....	5-1
5.1	Calibrate Using the Front Panel.....	5-1
5.1.1	Input Calibration	5-1
5.1.2	Output Calibration	5-6
5.2	Calibrate Using OMNICONNECT™	5-9
5.2.1	Analog Inputs	5-9
5.2.2	Analog Outputs.....	5-13
6.	Acceptance Testing Guidelines	6-1
6.1	Acceptance Testing Participants	6-1
6.2	Acceptance Test Procedure	6-2
6.3	Acceptance Test Tools	6-2
6.4	Prepare for Acceptance Testing	6-2
6.5	Post Acceptance Testing	6-3
6.5.1	Acceptance Testing Action Items.....	6-3
6.5.2	Records	6-3
6.6	Acceptance Test Procedure Checklist.....	6-4
7.	Troubleshooting	7-1
7.1	Calibration.....	7-1
7.1.1	Reset Individual Channels	7-1
7.1.2	Reset Multiple Channels	7-2
7.2	Troubleshooting Tables	7-1
7.2.1	Hardware	7-1
7.2.2	Alarms	7-9
8.	Technical Specifications.....	8-1
Appendix A.	Jumper Settings	A-1

OMNI Flow Computers Inc.

Our Mission

OMNI Flow Computers Inc. sets the world's standard for the design, development and manufacture of flow computers. For more than 25 years, we have supplied high-integrity equipment to offshore production facilities, oil and gas pipelines, terminals, refineries and petrochemical and gas plants worldwide.

We are determined to be the best in what we do, which is driven by our commitment to providing an excellent customer experience. We offer a multi-tiered promise to our customers, employees and business partners, which includes:

- Actively communicating with customers, integrators and original equipment manufacturers.
- Collaborating with our customers to determine the best solutions.
- Providing superior performance based on quality metrics.
- Operating with integrity and traceability.
- Providing continuous, relevant innovation that builds upon, rather than obsoletes, previous generations.

Our Users

Worldwide industries that use our products include:

- Offshore oil and gas production facilities.
- Crude oil, refined products, liquefied petroleum gas (LPG), natural gas liquids (NGL) and gas transmission lines.
- Storage, truck and marine loading/offloading terminals.
- Refineries, petrochemical and cogeneration plants.

Contact Us

We are committed to our products, our people and our customers. To contact our corporate headquarters:

Visit:	OMNI Flow Computers, Inc. 12320 Cardinal Meadow Dr. Suite 180 Sugar Land, TX 77478 http://www.omniflow.com/
Phone:	281-240-6161
Fax:	281-240-6162
E-mail (Sales):	sales@omniflow.com
E-mail (Support):	helpdesk@omniflow.com

Copyright Information

OMNI Flow Computers, Inc. owns the content of this user manual in its entirety, including, but not limited to, pictures, logos, trademarks and resources. OMNI Flow Computers, Inc. authorizes its customers to download and print this manual for professional information purposes only.

OMNI Flow Computers, Inc. expressly prohibits the usage, copy, storage, distribution, modification or printing of this manual or its content for any other purpose without written consent.

OMNI Flow Computers, Inc. believes that the information contained in this manual is accurate in all respects. However, OMNI Flow Computers, Inc. assumes no responsibility for any error or omissions in this document. OMNI Flow Computers, Inc. reserves the right to revise this document and to make changes from time to time in the content hereof without obligation of OMNI to notify any person or company of such revision or changes. This does not constitute in any way a commitment by OMNI to make such changes. OMNI Flow Computers, Inc. may issue a revision of this manual or a new edition of it to incorporate such changes.

The OMNI Flow logo, "OMNI", "OMNICOM" and "Measure the Difference", are registered trademarks of OMNI Flow Computers, Inc., in the United States and other countries. "OMNICONNECT" and "OMNIPANEL" are trademarks of OMNI Flow Computers, Inc., in the United States and other countries. All other trademarks are the property of their respective owners

Warranty, Licenses and Product Registration

Refer to the Terms and Conditions associated with your purchase order for the OMNI 4000/7000 flow computer warranty, licenses and product registration.

Document Conventions

Document conventions help you navigate through the information in this manual. Instructions are contained inside grey tables and use the following conventions:

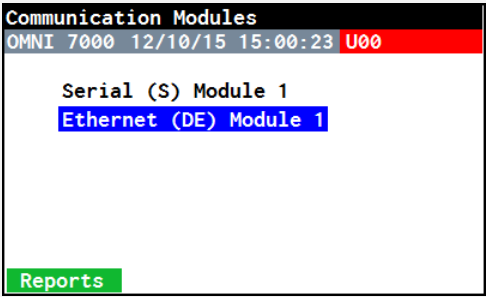
1.	Labeled cables and connections are bolded in the instructions: Connect I/O Cable A connector to CONN A on the motherboard.	
2.	Front panel screen and function key selections are bolded in the instructions: <ul style="list-style-type: none">• Scroll to select Ethernet (DE) Module 1.• Press the Reports function key to run a report.	

3. OMNICONNECT™ screen, window, field and button labels are bolded:
 - Click **Apply** to save any selections or any edits made to fields before moving to the next screen.
 - In the **Setup Sites** window, click **Add Site** to open the **Setup Communications** window.
- OMNI 7000: Liquid KF US 2.05.06.00 (Database: 1.00)

4. A white box outlined in blue in an instructional step provides information that you need to know.

This will help you complete the action.
 5. F1 in an instruction step is a prompt for you to go to OMNICONNECT Help for additional details to perform an action. Your cursor must be on the OMNICONNECT screen for F1 to open to the correct help file.

Press F1 to access OMNICONNECT Help for assistance.

Boxes with icons provide important information. When an icon alerts you to a potential safety concern, observe these precautions to prevent injury to people or damage to equipment.

- 

The tip icon indicates additional information about the current topic.
- 

The bookmark icon indicates a reference to another guide in this series.
- 

WARNING:
The warning icon indicates a definite risk of danger to personnel or damage to equipment. Failure to observe and follow proper procedures could result in serious or fatal injury to personnel or significant property loss or equipment damage.
- 

CAUTION:
The caution icon indicates a potential risk of injury to personnel or damage to equipment. Take extreme care when performing operations or procedures preceded by this symbol.
- 

Earth Ground Requirements:
The Earth Ground requirements icon reminds operators to verify that grounds are connected when there is a possibility of electrical shock.



The electrostatic icon reminds operators to observe the precautions for handling electrostatic-sensitive devices.



The recycle icon provides recycling instructions for the item.

1. The OMNI 4000/7000 Series

The Installation Guide for the OMNI 4000 and OMNI 7000 series of flow computers includes:

- An overview of the OMNI 4000/7000 flow computer.
- Installation instructions.
- Configuration instructions.
- Calibration instructions.
- Acceptance testing guidelines and troubleshooting.

Review these instructions and guidelines to ensure a safe installation and startup of your OMNI 4000/7000 flow computer.

1.1 Users of the Guide

As a user reference guide, the OMNI 4000/7000 Installation Guide is intended for an audience with knowledge of liquid and gas flow measurement technology. The user does not need to be an expert to use certain portions of this manual. However, some flow computer features require a certain degree of expertise and/or advanced knowledge of liquid and gas flow instrumentation and electronic measurement.

This manual is written for:

- Installers.
- System and Project Managers.
- Engineers and Programmers.
- Advanced Technicians.
- Operators.

Only qualified personnel should install, configure and calibrate OMNI flow computers.

1.2 Certifications and Standards

OMNI 4000/7000 flow computers have earned the following certifications:

Nederland Meetinstituut (NMI)

2004/108/EC	Electromagnetic Compatibility Directive
2004/22/EC	Measuring Instruments Directive
OIML R117-1	Dynamic Measuring Systems for Liquids Other Than Water Standard, Edition 2007; part of MID Software Guide–Measuring
WELMEC 7.2	Software Guide Measuring Instruments Directive, Chapter P and Extensions L, T, S, D and I5, Edition 2015
WELMEC 8.8	General and Administrative Aspects of the Voluntary System of Modular Evaluation of Measuring Instruments under the MID, Edition 2:2012
EN 55011:2009+ A1:2010	Industrial, Scientific and Medical (ISM) Equipment–Radio-Frequency Disturbance Characteristics

Nederland Meetinstituut (NMI)

EN 61326-1:2013	Electrical Equipment for Measurement, Control and Laboratory Use– EMC Requirements–Part 1: General Requirements
EN 12405-1:2005+ A2:2010	Gas Meters - Conversion Devices - Part 1: Volume Conversion, Edition 2005+A2:2010

European Conformity (CE)

2011/65/EU	Restriction of Hazardous Substances in Electronic Equipment (RoHS2) Directive
CE 93/68/EEC	Marking as per European Conformity Directive

TÜV Rheinland

UL 60950-1:2007	Information Technology Equipment–Safety–Part 1: General Requirements
UL 61010-1	Issued: 2004/07/12 Ed: 2 Rev: 2008/10/28 UL Standard for Safety Electrical Equipment for Measurement, Control, and Laboratory Use; Part 1: General Requirements
CSA C22.2 61010-1	Issued: 2004/07/12 Ed: 2 (R2009) Safety Requirements for Electrical Equipment for Measurement, Control, and Laboratory Use Part 1: General Requirements, with general instruction No. 1:2008/10/28– (R2009)
ISO 9001:2015	Issued: 2018/08/15 Quality management system Requirements

1.2.1 IEC Test Procedure Compliance

To meet the standards/directives in Section 1.2, the OMNI 4000/7000 models comply with the IEC test procedures listed in this section.

IEC 60068-2-1	Environmental testing–Part 2-1: Tests–Test A: Cold
IEC 60068-2-2	Environmental testing–Part 2-2: Tests–Test B: Dry heat
IEC 60068-2-47	Environmental testing–Part 2-47: Test–Mounting of specimens for vibration, impact and similar dynamic tests
IEC 60068-2-64	Environmental testing–Part 2-64: Tests–Test Fh: Vibration, broadband random and guidance
IEC 60068-3-1	Environmental testing–Part 3: Background information–Section One: Cold and dry heat tests
IEC 60068-3-4	Environmental testing–Part 3-4: Supporting documentation and guidance– Damp heat tests
IEC 60654-2	Operating conditions for industrial-process measurement and control equipment–Part 2: Power
IEC 61000-2-1	Electromagnetic Compatibility (EMC)–Part 2: Environment–Section 1: Description of the environment–Electromagnetic environment for low-frequency conducted disturbances and signaling in public power supply systems
IEC 61000-4-1	Electromagnetic Compatibility (EMC)–Part 4-1: Testing and measurement techniques–Overview of IEC 61000-4 series

IEC 61000-4-2	Electromagnetic Compatibility (EMC)—Part 4-2: Testing and measurement techniques—Electrostatic discharge immunity test
IEC 61000-4-3	Electromagnetic Compatibility (EMC)—Part 4-3: Testing and measurement techniques—Radiated, radio-frequency, electromagnetic field immunity test
IEC 61000-4-4	Electromagnetic Compatibility (EMC)—Part 4-4: Testing and measurement techniques—Electrical fast transient/burst immunity test
IEC 61000-4-5	Electromagnetic Compatibility (EMC)—Part 4-5: Testing and measurement techniques—Surge immunity test
IEC 61000-4-6	Electromagnetic Compatibility (EMC)—Part 4-6: Testing and measurement techniques—Immunity to conducted disturbances, induced by radio-frequency fields
IEC 61000-4-8	Electromagnetic compatibility (EMC)—Part 4-8: Testing and measurement techniques—Power frequency magnetic field immunity test
IEC 61000-4-17	Electromagnetic Compatibility (EMC)—Part 4-17: Testing and measurement techniques—Ripple on D.C. input power port immunity test
IEC 61000-4-29	Electromagnetic Compatibility (EMC)—Part 4-29: Testing and measurement techniques—Voltage dips, short interruptions and voltage variations on D.C. input port immunity tests
IEC 61000-6-1	Electromagnetic compatibility (EMC)—Part 6-1: Generic standards—Immunity for residential, commercial and light-industrial environments
IEC 61000-6-2	Electromagnetic compatibility (EMC)—Part 6-2: Generic standards—Immunity for industrial environments
IEC 61000-6-4	Electromagnetic compatibility (EMC)—Part 6-4: Generic standards—Emission standard for industrial environments

1.2.2 Measurement Security and Firmware Downloads (WELMEC 7.2 Extension D)

The OMNI 4000 and 7000 models have 16 password levels for protecting parameters and firmware download permission. When software sealing for parameters and firmware is applied, the highest level is reserved for Weights and Measures Agents and other agencies that act in the same way. Through software sealing, all communication ports can be set to 'read-only'.

Only licensed firmware files can be transmitted.

This method of firmware transmission meets all requirements of WELMEC 7.2 2015 Extension D, Software Guide—Measuring Instruments Directive.

1.3 Calculations

The OMNI 4000/7000 includes, but is not limited to, support for the following calculations:

Liquid (U.S.)	
API MPMS 11.1 (2007) Commodity Types: <ul style="list-style-type: none"> • Crude oil • Refined products • Lubricating oil • Special Applications 	Crude Oil Historical Tables (API 2540/ASTM D1250, 1952 edition) <ul style="list-style-type: none"> • Table 23/24 • Table 5/6
ASTM D1555 Aromatic Hydrocarbons	API 11.2.4-23E/24E-(GPA TP27) <ul style="list-style-type: none"> • LPGs • NGLs
Mass Calculation	
Liquid (Metric)	
API MPMS 11.1 (2007) <ul style="list-style-type: none"> • Crude oil • Refined products • Lubricating oil • Special applications 	Crude Oil Historical Tables (API 2540/ASTM D1250, 1952 edition) Table 53/54
ASTM D1555M Aromatic Hydrocarbons	API 11.2.4-53E/54E-(GPA TP27M) <ul style="list-style-type: none"> • LPGs • NGLs
Mass Calculation	Alcohols <ul style="list-style-type: none"> • Alcohol (ABNT NBR 5992:2008) • Alcohol (OIML) R22
Gas (U.S.)	
Heating Value Calculation <ul style="list-style-type: none"> • GPA 2172 2009 • ISO 6976 60/60F • AGA 5 2009 	Density Calculations AGA-8 1994 <ul style="list-style-type: none"> • Method 1-Detailed Analysis • Method 2-HV/SG/CO2 • Method 3-SG/N2/CO2
Viscosity Calculatin: LBC	Flow Calculations API 14.3 (AGA-3): 2012
ASME MFC 3M (Non-Flange DP types)	Isentropic Exponent Calculation: Estimated

Gas (Metric)	
Flow Calculations <ul style="list-style-type: none"> • ISO 5167:2003 • API 14.3 (AGA-3): 2012 	Density Calculations: AGA-8 1994 <ul style="list-style-type: none"> • Method 1-Detailed Analysis • Method 2-HV/SG/CO2 • Method 3-SG/N2/CO2
Heating Value Calculation <ul style="list-style-type: none"> • GPA 2172 2009 • AGA-5 2009 • ISO 6976 1995 	SGERG 1988 <ul style="list-style-type: none"> • Method 2-HV/N2/SG/H2 • Method 3-N2/CO2/SG/H2 • Method 4-HV/N2/CO2/H2
Viscosity Calculation: LBC	ISO 12213-3 2006 (SGERG) Method 1-HV/N2/SG/H2
	Isentropic Exponent Calculation: Estimated
Speed of Sound	
<ul style="list-style-type: none"> • AGA 10 	

1.4 Equipment Overview

OMNI 4000s and 7000s are microprocessor-based flow computers that perform liquid and gas flow calculations in accordance with the methods listed in Section 1.3 Calculations.

The flow computer connects to field transmitters in single and multiple meter run applications to monitor:

- Liquid and gas flow measurements in the pipeline.
- Custody transfer applications.

The flow computer calculates flow values and displays additional data and measurement information, which can be transmitted over communication channels and printed, as needed.

In addition, audit trail logs are available for registering changes to measurement parameters and firmware updates. The audit trail can be printed directly from the front panel of the flow computer or viewed with the OMNICONNECT software when connected to a computer.

All input/output (I/O) modules are quality tested and temperature trimmed to optimize analog inputs before the flow computer is shipped.

On-site, OMNI 4000/7000 flow computers are configurable, but not programmable. We do this to prevent the modification of WELMEC-approved software code, which could render an existing EC-evaluation certification invalid.

With an OMNI flow computer, the factory-programmed software does not need modification in the field. This preserves the integrity of existing certifications and provides assurance that software and firmware have been validated and cannot be modified.

Every OMNI 4000/7000 flow computer has the following components and features:

Hardware

- 7201 central processing unit (CPU)
- 4.3-inch (10.922 cm) Color LCD with 800 x 480 resolution
- USB Mini-B port on the front panel for configuring the flow computer
- USB-A Host port on the front panel for updating the OMNI CPU firmware using a memory stick
- USB Mini-B port on the CPU for configuration or updating the OMNI CPU firmware using OMNICONNECT
- Dual Ethernet (DE) module with:
 - 2 onboard RJ-45 100 Mbps Ethernet jacks
 - 10 Mbps using the back panel
- Expandable to allow for 2 DE modules (4 physical Ethernet ports for a total of 32 virtual connections).
- Expandable to allow for up to 10 Serial ports with different combinations of DE and S cards. *Must purchase separately.*
- Digital I/O Multiplexer (DM) module with 10 independent channels
- Digital I/O channels that support up to 3 externally installed Digital Terminals (DTs), which can be used in sequence. Each DT contains 16 I/Os. *DTs are optional purchase items.*
- 2 local printers, which can be connected to any serial port

Software

- All firmware applications in one programming file
- Daily, Batch, and Prove Historical Reports and for gas applications, a Detailed Daily report:
 - The 35 most recent reports are stored in the CPU memory.
 - Older reports are stored on the SD card, which has capacity of 8 GB of data.
 - 2 GB is allocated for each report type.
- Audit trail and alarm reports
- User database mapping provides standardization of local data maps or custom interfacing*
- Increased Boolean and variable statements—128 statements with a 32-character length allowing technical flexibility to build in custom functions
- Support for 6 Meter Runs, which can be configured for Liquid and Gas measurement independently
- 2 sets of detector switches for dual prover volumes
- Selectable master meter prove meter
- Increased security settings:
 - 1 Administrator and 16 users with separate permissions
 - 8 passwords allowing assignment of different permission for each port
- A full audit feature, with separate reports for the system and measurement audits
- Support for:
 - SSL*
 - Dual Stations*
 - A Gas/Liquid combination mode*

*These features require the purchase of a Standard firmware license (not included in the Basic firmware license).

1.5 Safety

1.5.1 Basic Electric Safety



Observe precautions for handling electrostatic-sensitive devices.

Take basic electrical safety precautions to prevent injury and equipment damage:

- Keep the area around the equipment clean and free of clutter.
- Verify that the power is not connected to the system when installing or removing main system components, including I/O modules.



CAUTION:

Do not hot swap I/O modules. Electrical shock may occur, resulting in injury to personnel and damage to the flow computer or connected field devices/control systems.

- Connect the power using a readily accessible disconnect device certified as being safe for the area.
- If an electrical accident occurs, disconnect the power to the system by removing the plug(s) from the outlet(s). Some systems may have multiple power cords that connect to more than one outlet.

1.5.2 Electrical Grounding Requirements

Follow these requirements for grounding equipment:

- The rack or cabinet that will house the flow computer must be properly Earth Grounded before installation.
- An Earth-Grounded electrical outlet must be available for all power cables.
- If using a power cable other than the factory-supplied cable, the power cord must include an Earth-Grounding pin.



Earth Ground Requirements:





Do not apply power before confirming that grounds are connected. Electrical shock can cause serious or fatal injury. Follow the National Electrical Code (NEC) and local codes for the safe installation of this equipment.

- To minimize the effects of electrical transients, the outer chassis of the flow computer must have a secure Earth Ground.

1.5.3 Safety Labels

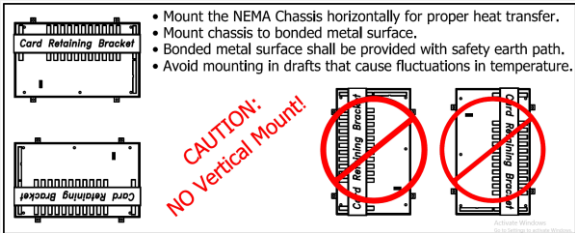
Table 1-1 describes the safety labels that are posted on the OMNI 4000/7000 flow computer.

Table 1-1: Safety Label Descriptions

<p>The No Vertical Mount safety label is located on the side of the National Electrical Manufacturers Association (NEMA) chassis where the I/O ribbon cables are connected and provides recommendations for mounting the NEMA chassis.</p> <p>The label reads:</p> <p>CAUTION: NO Vertical Mount!</p> <ul style="list-style-type: none"> • <i>Mount the NEMA Chassis horizontally for proper heat transfer.</i> • <i>Mount chassis to bonded metal surface.</i> • <i>Bonded metal surface shall be provided with a safety earth path.</i> • <i>Avoid mounting in drafts that cause fluctuations in temperature.</i>
 <p>The Earth Ground safety label is located below the Earth Ground connection on the chassis. It indicates where to connect the flow computer to safety Earth Ground.</p>
 <p>The alternating current (AC) voltage safety label is located below the Serial Number label on the Panel mount chassis and on the side of the NEMA chassis. It denotes the specified AC voltage at which the flow computer operates.</p>
 <p>The fuse safety label is located on the panel mount back panels and provides the proper fuse specifications for the OMNI 4000/7000.</p>

2. OMNI 4000/7000 Overview

The OMNI 4000/7000 flow computer is supplied with firmware and Windows PC configuration software that allow a single flow computer to perform a wide range of flow measurement tasks simultaneously, including:

- Multiple meter run totalizing, batching, proving and data archiving.
- Flow and control.
- Communications protocols (selectable) to directly interface with Distributed Control Systems (DCSs), Programmable Logic Controllers (PLCs) and Supervisory Control and Data Acquisition (SCADA) host systems.

The flow computer database numbers thousands of data points and provides tight communications coupling between the SCADA and the metering system.

2.1 Hardware

Front Panel

The front panel of the flow computer features an active alarm Light-emitting Diode (LED), a color graphics display and a 25-key keypad for navigation, menu, data selection and data entry. The front panel provides the capability to configure system parameters, view flow data, perform I/O calibrations and print reports.

Back Panel

All signal I/O terminals and power connector/terminals are located on the back panel. The OMNI 4000 has four I/O terminal blocks and the OMNI 7000 has ten I/O terminal blocks.

All flow measurement inputs are first received at the back panel and then through plug-in I/O combination (combo) modules. Four types of combo modules are available: A, B, E and E/D.

Flow computers may be used to interface with any approved compatible 4-20 mA or 1-5 V temperature, pressure and differential pressure transmitter from the back panel. They can also receive direct inputs from 4-wire, 100-ohm Resistance Temperature Detectors (RTDs), which conform to either Deutsches Institut für Normung (DIN) IEC 751 or American curves.

Pulse inputs from any approved turbine, ultrasonic or mass flow meter may be used.

Chassis

The chassis houses the I/O modules, the motherboard, the CPU and the power supply.

CPU Module

All custody transfer measurement programs and configurations can be stored in non-volatile memory for up to 10 years without power. This method prevents damage caused by electrical noise or tampering with the integrity of calculation specifications, and it does not rely on a battery.

2.2 Firmware

Real-time Operating System

The real-time operating system and Dual Ethernet adapt to load placement, which creates a high-speed, multitasking environment and quick turnaround on all communications. The operating system adapts to meet increased demand, and its pre-packaged, certified and standardized code makes the software easier to maintain.

Cycle Time

The flow computer performs all time-critical measurement functions every 500 milliseconds or less. For example, the Digital MUX, pulse density and double chronometry critical functions occur every 10 milliseconds. This cycle time makes measurement calculations more accurate and permits faster pipeline operations response for critical control functions, such as opening or closing valves.

Online Diagnostics and Calibration

Diagnostic software is built into the system so that a technician can debug a possible problem remotely without interrupting online measurement. Technicians can also remotely test Modbus communications through a unique Modbus register master simulator that is built in-to the software.

The flow computer has an automatic, two-point calibration system. The operator inputs the high and low points of the calibrator into the flow computer, which then calculates the calibration.

CPU Firmware

Firmware is stored in flash memory, which is located in the CPU module. The firmware contains the liquid and gas flow calculations for both metric and US standard units.

Firmware can be updated in two ways:

- With a factory-provided Universal Serial Bus (USB) flash drive
- Through OMNICONNECT when connected to the USB port on the CPU

2.3 Software

OMNICONNECT™

Online or offline configuration of OMNI 4000 and 7000 models is possible using a personal computer that is capable of running the OMNICONNECT software. This software manages the flow computer's security, supports the updating of the CPU's firmware and allows entire disk configurations to be copied, modified and saved. Several channels can be used to connect to the flow computer: the Serial ports, Ethernet ports, a front panel USB port and a CPU USB port.

Each OMNICONNECT license is assigned to an individual PC or laptop.

OMNIPANEL™

The OMNIPANEL™ software remotely replicates all the functionality of the OMNI 4000/7000 flow computer's front panel for times when physical access to the flow computer is not possible.

Network Utility

OMNI Network Utility is part of the OMNI software suite, and is used to view the configuration settings of the DE module and to upgrade the DE module firmware (Figure 2-1). However, the program cannot be used to modify the DE module configuration settings. This must be completed through OMNICONNECT, although some of the settings required to establish communications can be modified from the flow computer front panel.

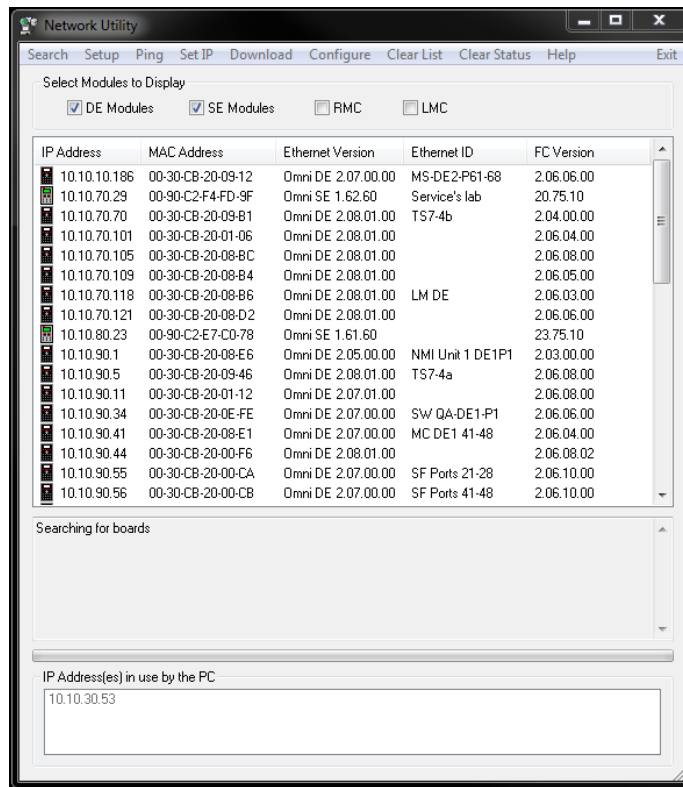

Figure 2-1: Network Utility Interface

Modbus Tester

The Modbus Tester is a Modbus Master that can test a device that implements a Modbus slave protocol, such as an OMNI flow computer. The tester can communicate using Modbus over TCP, RTU or ASCII protocol. The register addressing can be Logical (1 float register is 4 bytes), Register (two consecutive 16-bit registers are combined to make 1 float) or Modicon compatible (two consecutive 16-bit registers are combined to make 1 float and the float bytes are swapped from 'aa bb cc dd' to 'cc dd aa bb').

The tester supports all the major function codes as well as user-defined function codes. It also supports a wide range of data types including Booleans and strings. You can repeat transmissions of one register with a delay and set up a list of registers for one transmission or repeated transmissions based on continuous, number of times, or over a date/time range.

3. Installation

This section provides instructions for installing the OMNI 4000/7000 flow computer, including connections to field devices. The drawings and figures in this section provide guidance for wiring.

Follow your project-specific wiring diagrams and drawings when installing the flow computer and connecting it to other devices.

3.1 Installation Requirements

When installing the OMNI 4000/7000 flow computer and associated equipment, follow these requirements (Figure 3-1):

- Mount the flow computer on a panel, cabinet or rack that is a bonded metal surface and is connected to an Earth Ground.
- Confirm that ambient operating conditions meet the following:
 - Relative humidity is 90% non-condensing
 - An operating temperature range of +14 °F to +140 °F (-10 °C to +60 °C)



CAUTION: I/O specifications are guaranteed within these operating conditions only.

- Do not cover the vent holes in the cabinet, rack or enclosure that provides cooling.
- Provide 2 inches (50 mm) of space between the flow computer and other equipment in the cabinet, rack or enclosure to allow for the free flow of air.
- Make sure other equipment located around the cabinet, rack or enclosure does not obstruct access to the flow computer.
- Verify that the cabinet, rack or enclosure that contains the flow computer is located in an area that is only accessible by qualified personnel.

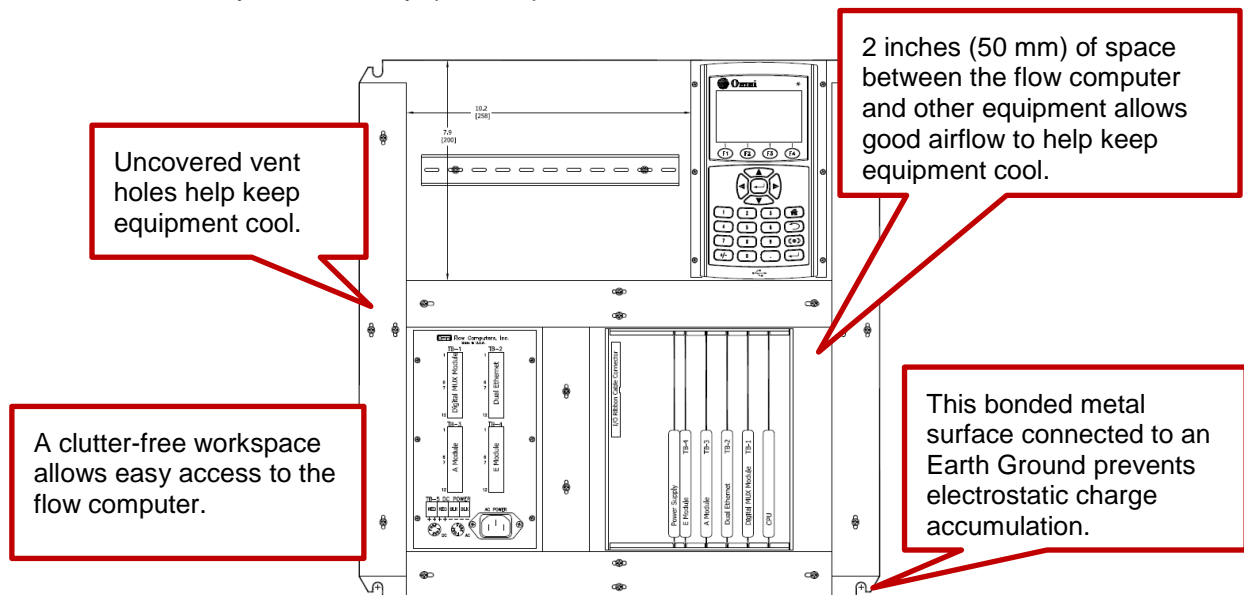

Figure 3-1: Installation Requirements Explained

3.2 Equipment Verification

The OMNI flow computer comes in one of three configurations depending on the mount option selected for a project. Confirm that the delivered equipment matches the project-specific requirements:

- Remove the equipment from its packaging.
- Inspect the flow computer and associated equipment to look for mechanical damages, dents and scratches.
- Compare the equipment to the project specifications and product data sheets.
- Confirm delivery of the equipment and parts listed in Table 3-1.

Table 3-1: OMNI 4000/7000 Mount Options and Associated Equipment

Panel Mount	Panel Mount with Extended Back Panel
Front panel, chassis and back panel (assembled)	Front panel and chassis (assembled)
Optional Digital I/O Terminal Board	Back panel (separate component)
Mounting hardware	Ethernet pigtails attached to the back panel
Ethernet pigtails attached to the back panel	Optional Digital I/O Terminal Board
Power cable when using AC power	Mounting hardware
OMNI USB key with OMNICONNECT software and standard drawings for different installation configurations	Extended power cable when using AC power
	Extended I/O ribbon cables
	OMNI USB key with OMNICONNECT software and standard drawings for different installation configurations
NEMA option	NEMA 4X Enclosure
Front panel (separate component)	Front panel (separate component)
Chassis (separate component)	Chassis (separate component)
Back panel (separate component)	Back panel (separate component)
Ethernet pigtails attached to the back panel	Ethernet pigtails attached to the back panel
Optional Digital I/O Terminal Board	Optional Digital I/O Terminal Board
Flow computer mounting hardware	Enclosure mounting hardware
Extended power cable when using AC power	Extended power cable when using AC power
Standard 18-inch (45.72 cm) front panel ribbon cable or optional extended 24-inch (60.96 cm) cable	Standard 18-inch (45.72 cm) front panel ribbon cable or optional extended 24-inch (60.96 cm) cable
Extended I/O ribbon cables	Extended I/O ribbon cables
OMNI USB key with OMNICONNECT software and standard drawings for different installation configurations	OMNI USB key with OMNICONNECT software and standard drawings for different installation configurations

3.3 Documentation Review

Before installing the OMNI 4000/7000 flow computer:

- Review the standard drawings, which provide guidance for:
 - Mechanical installation of the flow computer and associated equipment.
 - Electrical wiring to the flow computer back panel.
- Refer to the product data sheets for project information.
- Refer to OMNI Technical Bulletins for specific installation options and instructions.



For reference, OMNI provides wiring diagrams in the standard drawings as a courtesy. Project-specific wiring is the responsibility of the installer.

3.4 Mount the OMNI 4000/7000 Flow Computer

Instructions for 4000/7000 flow computer mounting options include:

- Panel mount
- NEMA mount
- NEMA 4X Enclosure

The diagrams included with the instructions for each mounting option illustrate the dimensions of the flow computer, the mounting panel and the NEMA 4 enclosure in inches (and millimeters).

Diagrams for the two panel mounts and the NEMA mount options include the minimum thickness recommendations for the mounting panel or plate. Go to Section 8 Technical Specifications for more information.

Panel Mount

The panel mount supports two flow computer configurations: a standard and an extended back panel. When using a standard configuration, the flow computer front panel, chassis and standard back panel components are pre-assembled into one piece, illustrated in Figure 3-2.



Figure 3-2: OMNI 4000/7000

When using a flow computer with an extended back panel, the front panel and chassis components are pre-assembled into one piece. The back panel, in either standard extended or short extended form, is a separate piece, as illustrated in Figure 3-3 and Figure 3-4.



Figure 3-3: OMNI 7000 with Extended Back Panel



Figure 3-4: OMNI 7000 with Short Extended Pack Panel

NEMA Mount and 4X Enclosure

The NEMA option and NEMA 4X enclosure support a flow computer configuration where the front panel, chassis and back panel are three separate components, as shown in Figure 3-5. For the NEMA 4X enclosure, these components are factory-mounted.

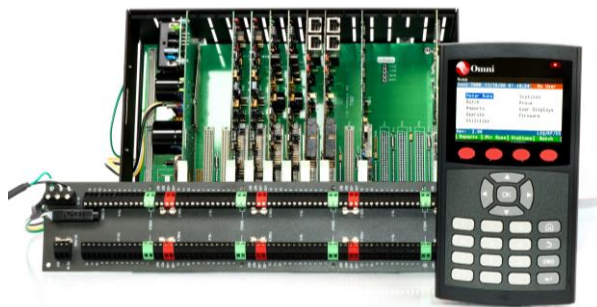

Figure 3-5: OMNI 7000 NEMA option

3.4.1 Panel Mount



CAUTION:

- A maximum system configuration of the OMNI 4000/7000 dissipates approximately 29 W, including transducer loop power, which causes an internal temperature rise of 27 °F (15 °C) over the ambient temperature.
- The flow computer should not be mounted in a cabinet or panel where the inside ambient temperature will exceed 131 °F (55 °C).

Figure 3-6 illustrates the standard OMNI 7000 flow computer's panel mount configuration. All dimensions are the same for the OMNI 4000 except for the depth, which is 9.5 inches (241.3 mm).

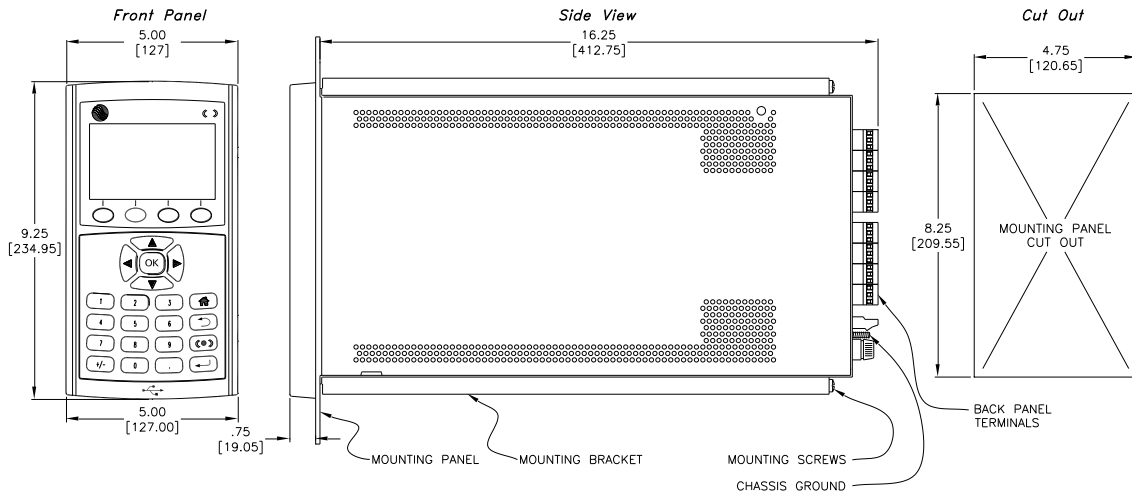
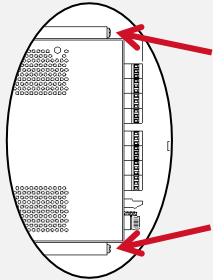

Figure 3-6: OMNI 7000 Panel Mount Configuration

To safely install a panel mount, follow these instructions:

1. Verify that the panel, cabinet, or rack used to house the flow computer is a bonded metal surface and is connected to an Earth Ground.
 2. Confirm that the mounting panel meets specifications, including thickness, and will support the weight of the flow computer.

Go to Section 8 for technical specifications.
- Based on flow computer weight, the minimum recommended thickness of the panel or plate used for mounting is 3/16 inch (4.8 mm).
 - If providing additional rear panel support before installation, the minimum recommended thickness is 1/8 inch (3.2 mm).

3. Cut out the mounting panel to specifications.
4. Slide the chassis into the cutout.
5. Tighten the mounting screws on the mounting brackets at the top and bottom of the chassis.
 
6. Connect the Earth Ground from the cabinet or rack to the Earth Ground stud on the back of the chassis.

3.4.2 Panel Mount with Extended Back Panel

Figure 3-7, Figure 3-8 and Figure 3-9 illustrate the OMNI 4000 and 7000 flow computer panel mount configurations with an extended back panel.

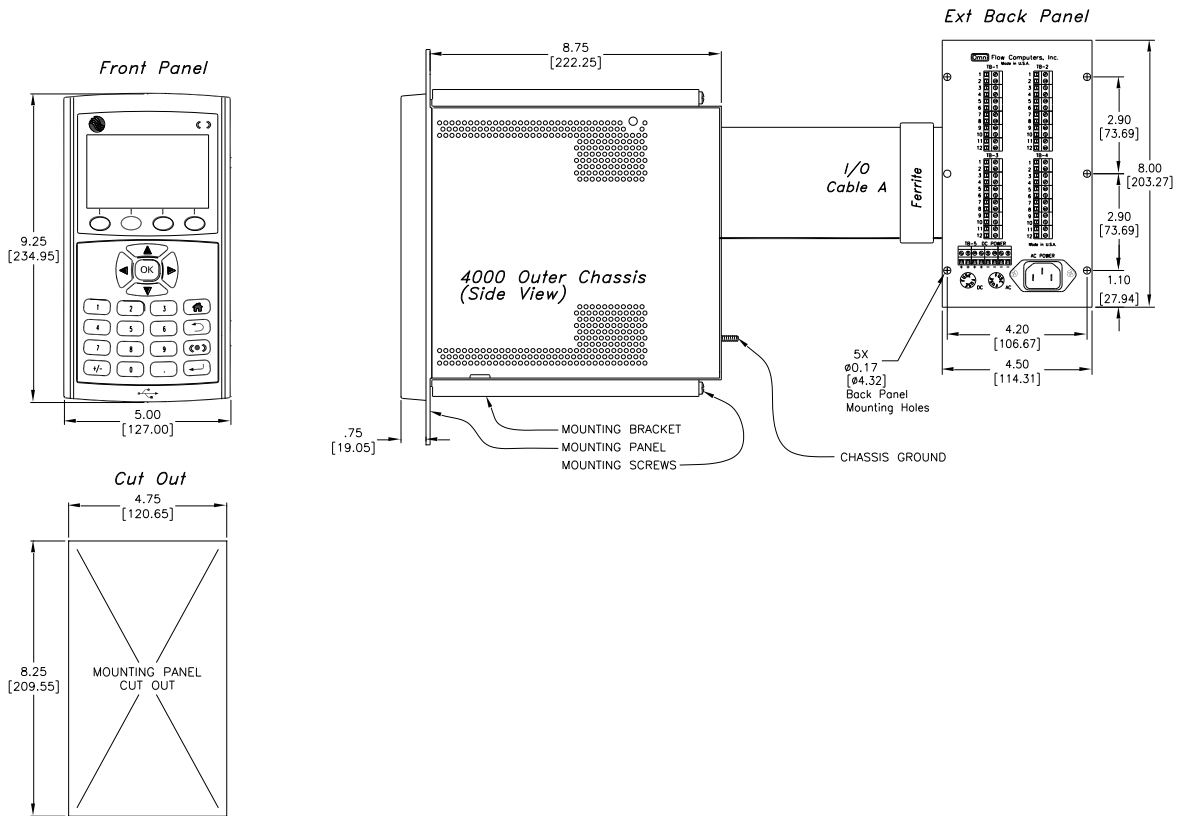

Figure 3-7: OMNI 4000 Panel Mount Extended Back Panel Configuration

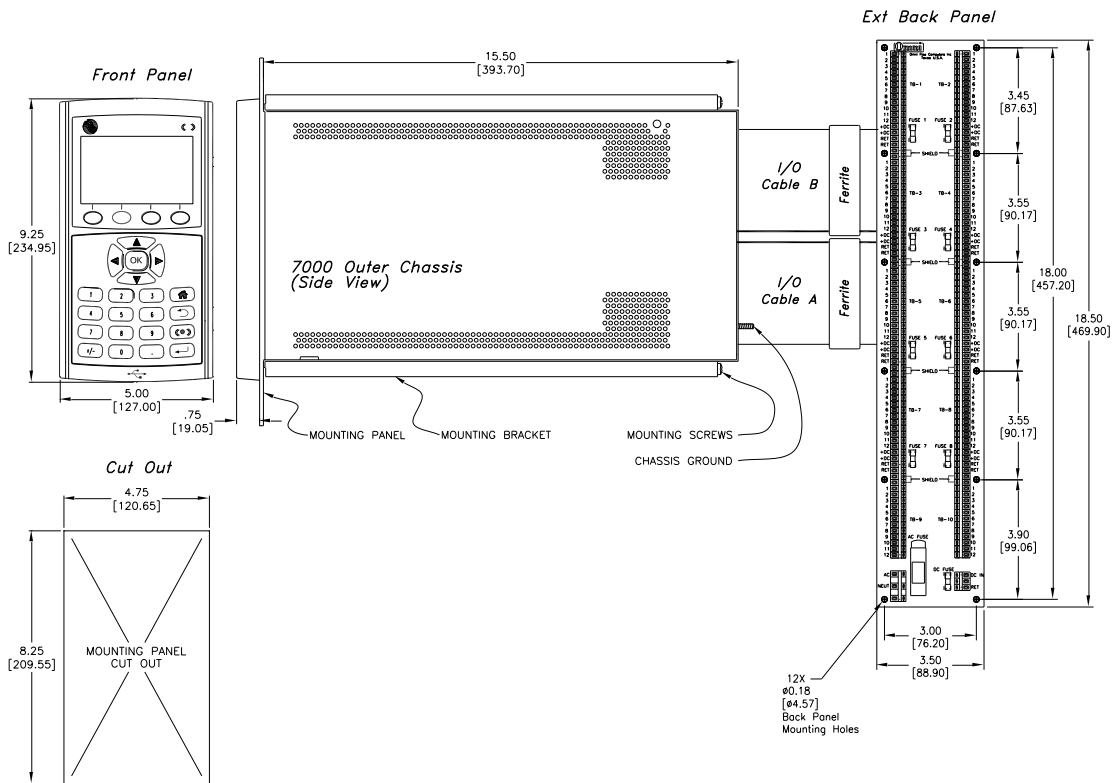

Figure 3-8: OMNI 7000 Panel Mount Extended Back Panel Configuration

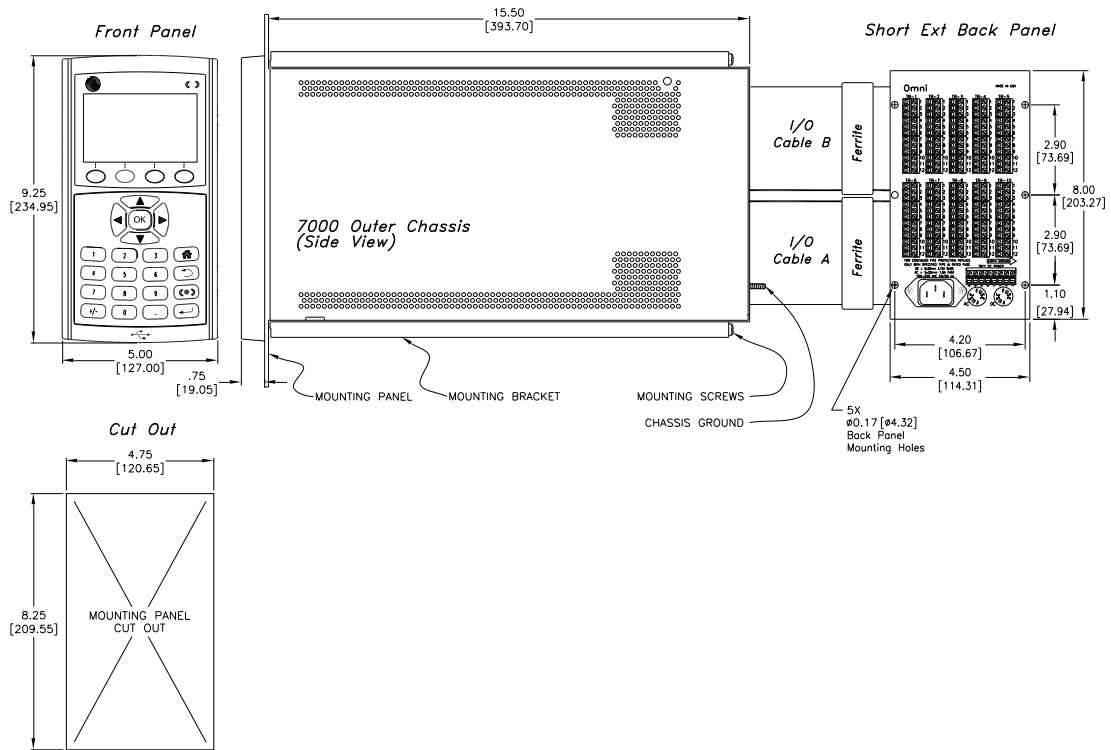

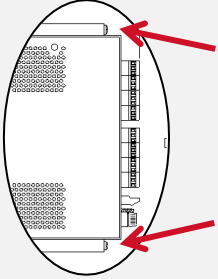

Figure 3-9: OMNI 7000 Panel Mount Short Extended Back Panel Configuration

To safely install a panel mount for an extended back panel, follow these instructions:

1. Verify that the panel, cabinet or rack used to house the flow computer is a bonded metal surface and is connected to an Earth Ground.
2. Confirm that the mounting panel meets specifications, including thickness, and will support the weight of the flow computer.
Go to Section 8 for technical specifications.
 -  • Based on flow computer weight, the minimum recommended thickness of the panel or plate used for mounting is 3/16 inch (4.8 mm).
 - If providing additional rear panel support before installation, the minimum thickness recommendation is 1/8 inch (3.2 mm).
3. Cut out the mounting panel to specifications.
4. Slide the chassis into the cutout.
5. Tighten the mounting screws on the mounting brackets at the top and bottom of the chassis.
6. Connect the Earth Ground from the cabinet or rack to the Earth Ground stud on the back of the chassis.
7. Verify that the surface where the extended back panel will be mounted is grounded.

8. Mount the extended back panel using the factory-provided mounting screws and standoffs.

The OMNI 4000 (and the OMNI 7000 with the short extended back panel) uses 5 screws. The OMNI 7000 with the standard extended back panel uses 12 screws.

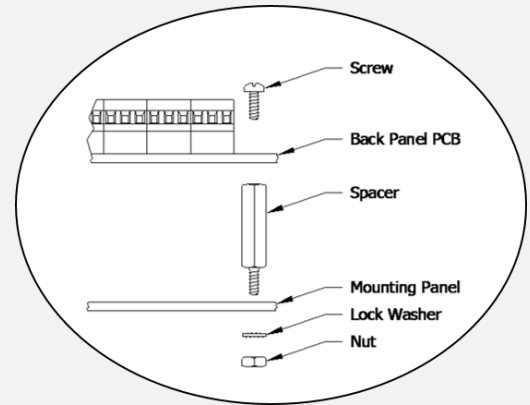

The OMNI 4000 back panel contains 6 holes, but only 5 can be used to mount the back panel because the 64-pin ribbon cable from the motherboard must be routed under the back panel.

3.4.3 NEMA Mount



 Locate the NEMA mount in a controlled, temperature stable environment.

Figure 3-10, Figure 3-11 and Figure 3-12 illustrate the OMNI 4000 and 7000 flow computer NEMA mount configuration, which includes the separate front panel, the standard extended back panel and the short extended back panel.

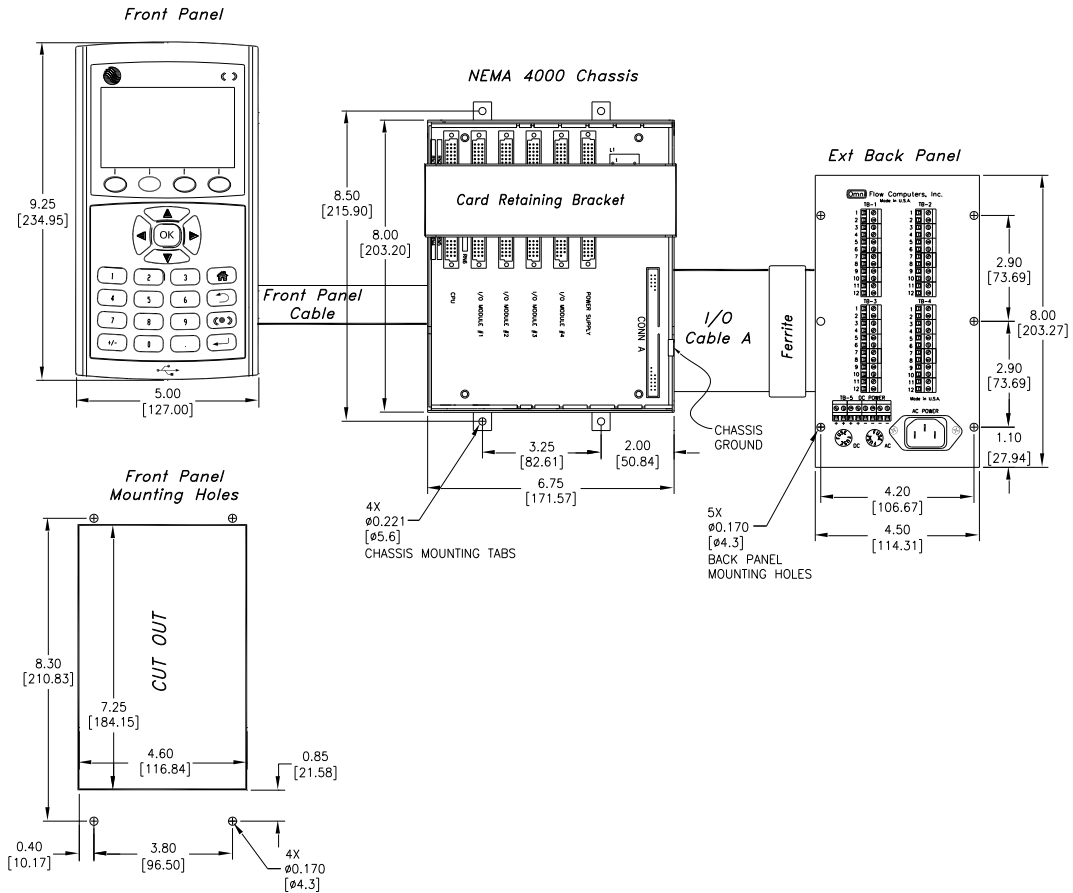

Figure 3-10: OMNI 4000 NEMA Mount

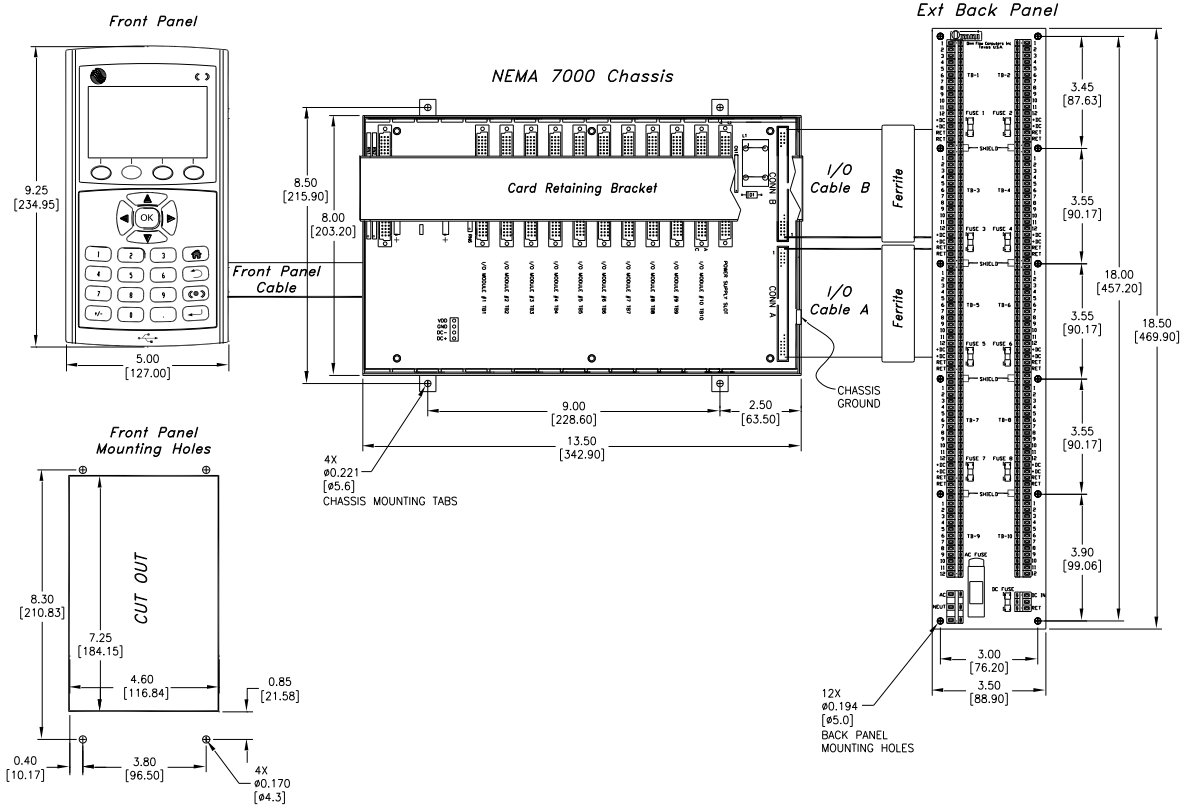

Figure 3-11: OMNI 7000 NEMA Mount

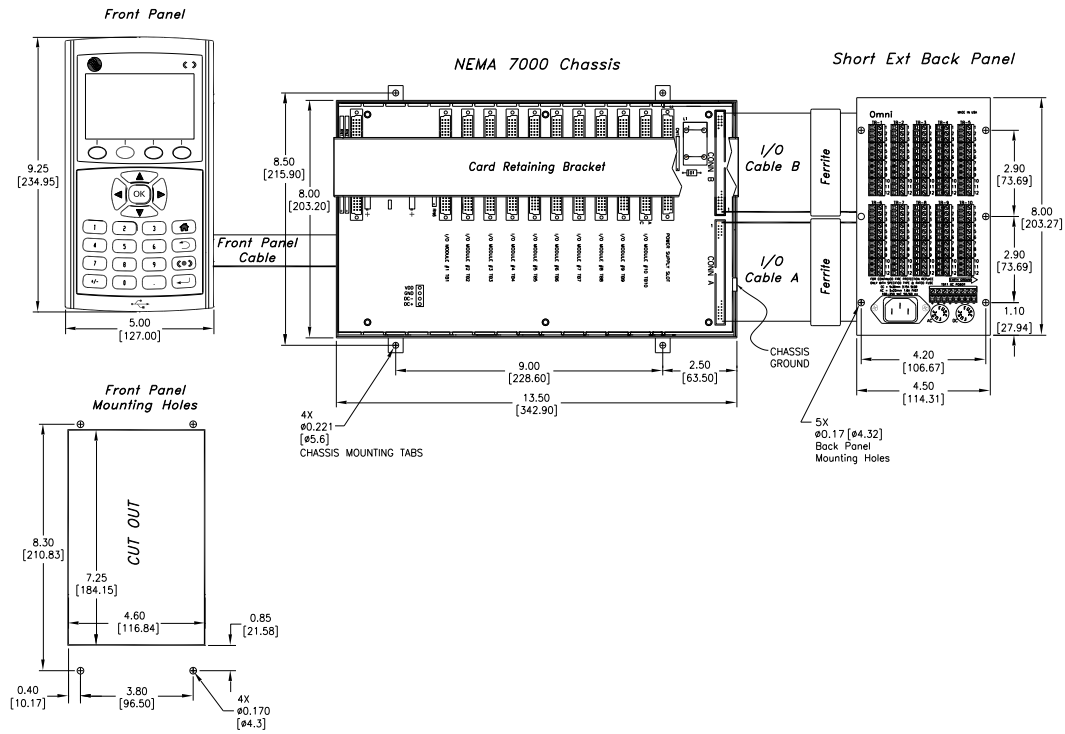

Figure 3-12: OMNI 7000 NEMA Mount with Short Extended Back Panel

To safely install a NEMA option, follow these instructions:

1. Verify the panel, cabinet or rack used to house the flow computer is a bonded metal surface and is connected to an Earth Ground.
2. Confirm that the rack or cabinet surface:
 - Meets specifications (including thickness).
 - Will support the weight of the flow computer.
 Go to Section 8 for technical specifications.
3. Cut out the front panel mounting plate as indicated in Figure 3-10 (OMNI 4000) or Figure 3-11 (OMNI 7000).
4. Use the 4 factory-supplied screws to mount the front panel where indicated in Figure 3-10 or Figure 3-11.



CAUTION: The maximum length of the ribbon cable that connects the keypad to the CPU module is 24 inches (610 mm). Any length beyond this is not supported.

5. Through the cutout, connect the 24-pin front panel ribbon cable to the front panel.

Front Panel Assembly
(Back Side)

Front panel cable to the CPU



CAUTION: Do NOT mount the NEMA chassis vertically. For proper heat transfer, mount the NEMA chassis flow computer **horizontally**.

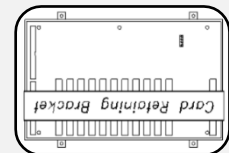
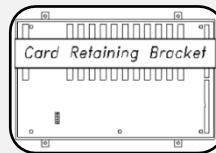

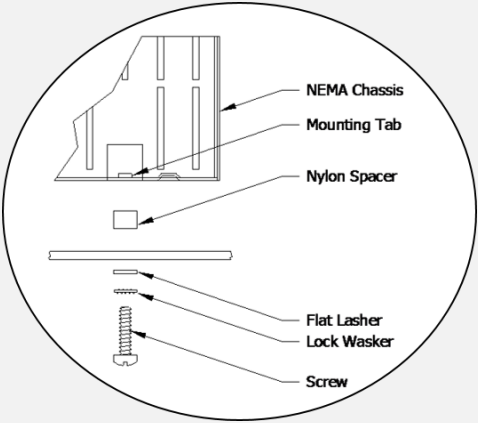
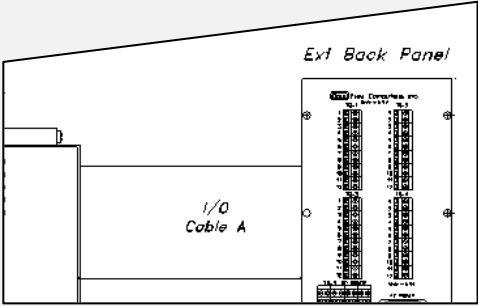
6. Mount the chassis using the 4 factory-supplied mounting screws and standoffs.
- 
7. Connect the Earth Ground from the cabinet or rack to the ground (GND) nut at the Earth Ground label on the end of the NEMA chassis.
8. At the chassis, connect the front panel ribbon cable to the CPU module **J8** connector.
9. Verify that the surface used for mounting the back panel is grounded.
10. To install the OMNI 4000 I/O cable, connect **I/O Cable A** to **CONN A** on the extended back panel.
- 
11. To install the OMNI 7000 I/O cables:
- Connect **I/O Cable A** to **CONN A** and **I/O Cable B** to **CONN B** on the extended back panel.
 - Verify that the cables are correctly connected.

12. Attach each provided Ferrite clamp to an I/O cable(s):
- Carefully open the cover latch of a clamp and position the clamp around **I/O Cable A**.
 - Secure the clamp cover latch.
 - Wrap the clamp with the provided non-static tape two times while removing the tape liner backing.

If you are installing the OMNI 7000, repeat for **I/O Cable B**.

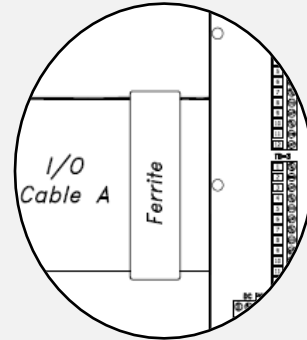

CAUTION: Do not remove the Ferrite clamp from the cable assembly after the clamp is attached. The ferrite clamp provides radio frequency interference suppression for electromagnetic compatibility and measuring instrument directives (MID) compliance.

13. Mount the back panel using the factory-supplied mounting screws and standoffs.

The OMNI 4000 (and the OMNI 7000 with the short extended back panel) uses 5 screws. The OMNI 7000 with the standard extended back panel uses 12 screws.

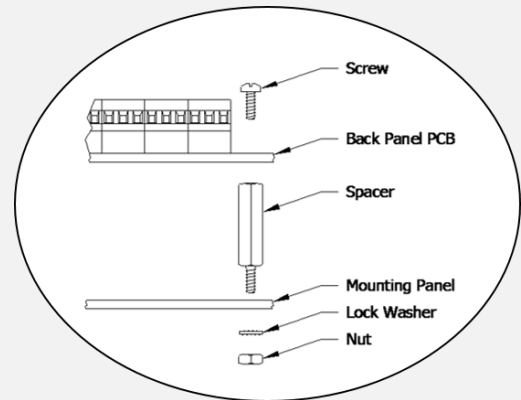

The OMNI 4000 back panel contains 6 holes, but only 5 can be used to mount the back panel because the 64-pin ribbon cable from the motherboard must be routed under the back panel.

14. To complete installing the OMNI 4000 I/O cable, connect **I/O Cable A** to the motherboard in the chassis at **CONN A**.

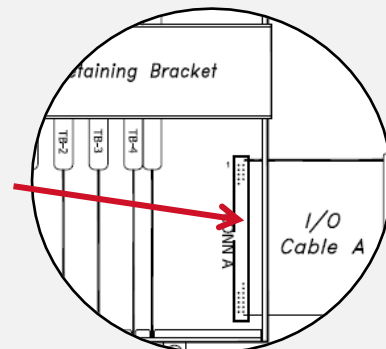

15. To complete installing the OMNI 7000 I/O cable:
 - a. Connect **I/O Cable A** to **CONN A** and **I/O Cable B** to **CONN B** on the motherboard in the chassis.
 - b. Verify that the cables are correctly connected.

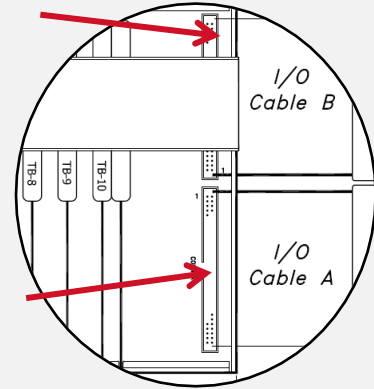

3.4.4 NEMA 4X Enclosure Installation

Figure 3-13 illustrates the NEMA 4X enclosure.

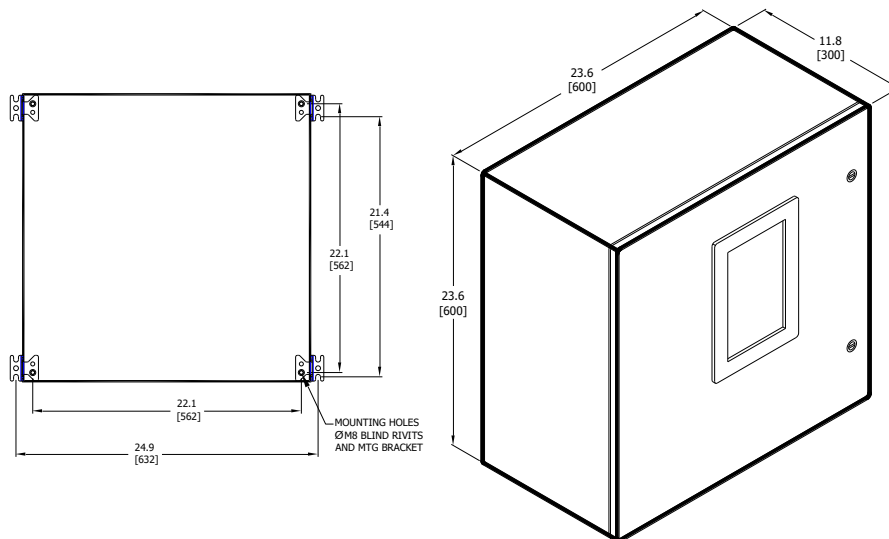

Figure 3-13: NEMA Enclosure

To safely install a NEMA enclosure, follow these instructions:

1. Verify that the surface of the structure where the enclosure will be mounted is a bonded metal surface and connected to an Earth Ground.



CAUTION: The approximate weight of a single OMNI 4000/7000 NEMA 4X enclosure is 87 lbs. (39.43 kg). The structure to which the enclosure will be mounted must be capable of supporting this weight.

2. Verify that the structure can support the weight of the enclosure.

3. Mount the enclosure to the surface of the structure using the factory-provided mounting brackets (see Figure 3-13).
4. Open the enclosure and connect the Earth Ground to the GND nut, which is located on the end of the NEMA chassis.
5. Perforate the side of the enclosure that is nearest to the flow computer's back panel to create two openings for inserting the power cables and field wires.

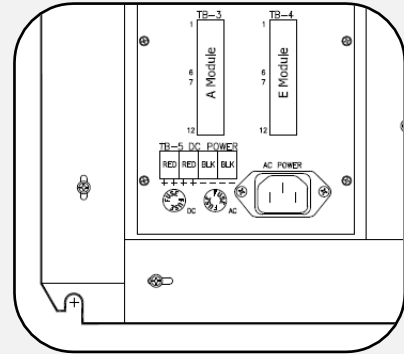

3.4.5 Optional Digital I/O Terminal Installation

To safely install a Digital I/O Terminal (DT) module, follow these instructions:

1. Verify that the DIN rail to which the Digital I/O Terminal module will be mounted is electrically bonded and connected to an Earth Ground.
2. Mount the DT board enclosure to a 1.38 x 0.3 inch (35 x 7.5 mm) DIN rail by snapping the feet of the enclosure to the DIN rail.
3. Connect the module to Earth Ground using the GND screw, which is located on the DT module.

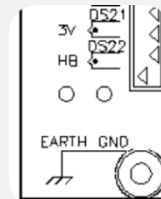

3.5 OMNI 4000/7000 Back Panel Terminal Blocks

The OMNI 4000 standard and extended back panel is illustrated in Figure 3-14.

- Terminal blocks TB-1 through TB-4 provide signal I/O terminations.
- The terminals for each terminal block, which are labeled 1 through 12, provide 48 circuit paths.
- Each terminal block corresponds to an I/O module slot on the motherboard.
- TB-5 provides DC power to various field devices when the flow computer is powered with AC.

Go to Section 8 for the electrical specifications of the back panel, such as the transducer output power.

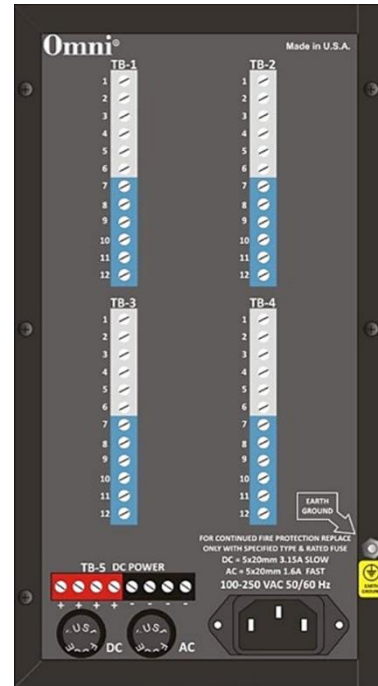

Figure 3-14: OMNI 4000 Back Panel

The OMNI 7000 standard back panel is illustrated in Figure 3-15.

- Terminal blocks TB-1 through TB-10 provide signal I/O terminations.
- The terminals for each terminal block, which are labeled 1 through 12, provide 120 circuit paths to the motherboard.
- Each terminal block corresponds to an I/O module slot on the motherboard.
- TB-11 provides DC power to various field devices when the flow computer is powered with AC.

Go to Section 8 for the electrical specifications of the back panel, such as the transducer output power.

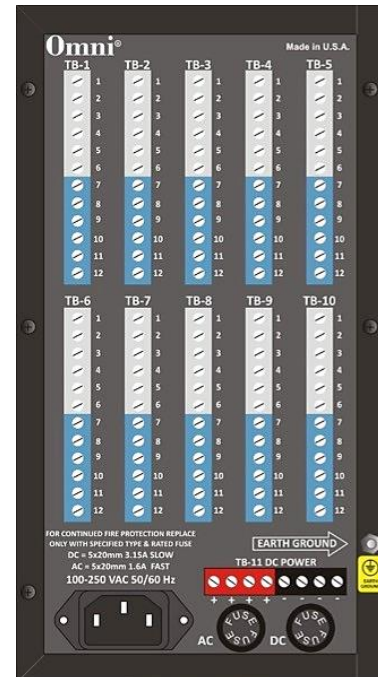

Figure 3-15: OMNI 7000 Standard Back Panel

The OMNI 7000 extended back panel is illustrated in Figure 3-16.

- Terminal blocks TB-1 through TB-10 provide signal I/O terminations.
- The terminals on each terminal block provide the same number of circuit paths as the OMNI 7000 standard back panel.
- TB-1 through TB-8 contain extra terminals to provide DC power to various field devices when the flow computer is powered with AC. The terminals include:
 - DC+ power with fuses.
 - DC return.
 - Shield connections.
- Screw-type terminals on the lower right and left provide AC and DC input power.

Go to Section 8 for the electrical specifications of the back panel, such as the transducer output power.

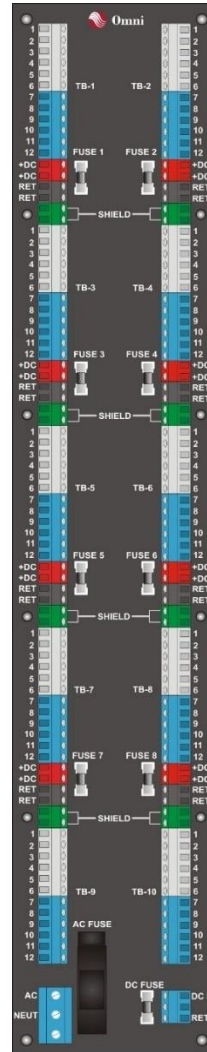

Figure 3-16: OMNI 7000 Extended Back Panel

3.6 Input and Output Modules Overview

The OMNI 4000/7000 flow computer functions by using the following I/O module types:

- Digital I/O Multiplexer (DM)
- Serial (S)
- Dual Ethernet (DE)
- Process I/O

The DM module provides inputs and outputs to control provers, samplers and injection pumps to provide remote totalizing.

The S or DE modules provide Ethernet and serial ports to communicate with devices such as printers, PCs, SCADA networks or other flow computers.

Process I/O modules provide the input and output of process measuring devices, such as temperature and pressure transducers, densitometers, flow meters and provers.



CAUTION: If the order of the modules in the chassis is modified, the configuration no longer matches the standard drawings provided. The wiring to the terminal blocks will need to be modified, and your project-specific drawings and documentation will need to be revised.

Figure 3-17 illustrates the standard factory order of the I/O modules in relation to the terminal blocks on the OMNI 4000 back panel:

- The TB-1 terminal block is used for the DM module.
- The TB-2 terminal block is used for a communication module.
- TB-3 and TB-4 are used for Process I/O modules.
- Each terminal block corresponds to an I/O module slot on the motherboard.

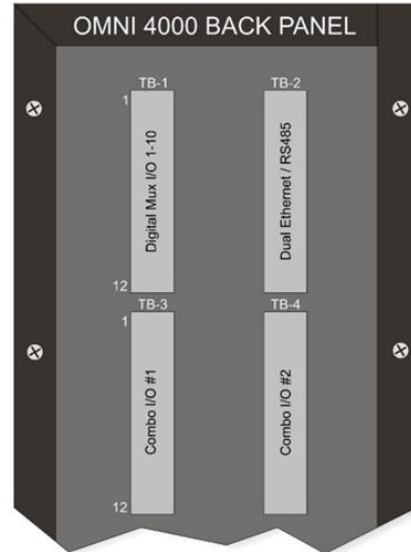

Figure 3-17: I/O Modules and the OMNI 4000 Back Panel

Figure 3-18 illustrates the standard factory order of the I/O modules in relation to the terminal blocks on the OMNI 7000 back panel:

- The TB-1 terminal block is used for the DM module.
- The TB-2 through TB-4 terminal blocks are used for DE modules or S modules (RS485 in this example), depending on the number of communication modules needed.
- The process I/O modules typically start from TB-3 to TB-5, depending on the number of communication modules. These modules vary in number, depending on project requirements.
- Each terminal block corresponds to an I/O module slot on the motherboard.

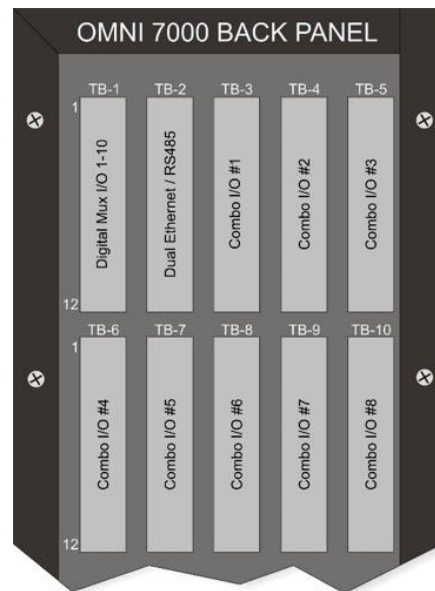

Figure 3-18: I/O Modules and the OMNI 7000 Back Panel

3.7 Connect to Field Devices



CAUTION: Only personnel who are experienced with field wiring should perform these procedures.



WARNING: When connecting main system components to the OMNI 4000/7000 back panel, verify that power is not connected to the system.

Follow these general guidelines for back panel wiring:

- The recommended wire size for back panel terminals is 18-22 AWG.
- When using a DC Power source, a common DC return is required on the back panel.
- The recommended wire size for AC input terminals on the extended back panel is 16-20 AWG.

Before wiring field equipment to the back panel, refer to the following:

- The standard drawings and product data sheets included with the OMNI 4000/7000 flow computer for guidance.
- Your project-specific requirements and wiring diagrams, particularly if project requirements differ from the factory default and standard drawings.
- The Technical Bulletins on OMNI's support website for installation options and examples of specific devices.



OMNI provides wiring diagrams in the standard drawings as a courtesy for guidance. Project-specific wiring is the responsibility of the installer.

3.7.1 Digital I/O Multiplexer

Each digital I/O point on the DM module may be independently configured as an input or output through the OMNICONNECT software. The first four digital points can be used for prove detector switch inputs for conventional pipe provers. All digital points are referenced to the direct current (DC) return of the flow computer.



Additional I/O points are available by adding one or more optional Digital I/O Terminal boards (Section 3.7.1 Digital I/O Multiplexer).

Connect wiring from the OMNI 4000/7000 back panel (TB-1) pinouts to a field device according to the project-specific drawings. **Error! Reference source not found.** describes the pinouts.

Table 3-2: Back Panel Wiring for the DM Module

Pinouts	Signal Name	Signal Type
1	Digital 1	Digital I/O or Detector Switch (SW) Input
2	Digital 2	Digital I/O or Detector SW Input
3	Digital 3	Digital I/O or Detector SW Input
4	Digital 4	Digital I/O or Detector SW Input
5	Digital 5	Digital I/O
6	Digital 6	Digital I/O
7	Digital 7	Digital I/O
8	Digital 8	Digital I/O
9	Digital 9	Digital I/O
10	Digital 10	Digital I/O
11	DT Comm Link H	High Speed Serial Link +
12	DT Comm Link L	High Speed Serial Link-

Figure 3-19 **Error! Reference source not found.** illustrates an example of DM module wiring to field devices. Always use your project specific drawings for wiring the DM module to field devices.

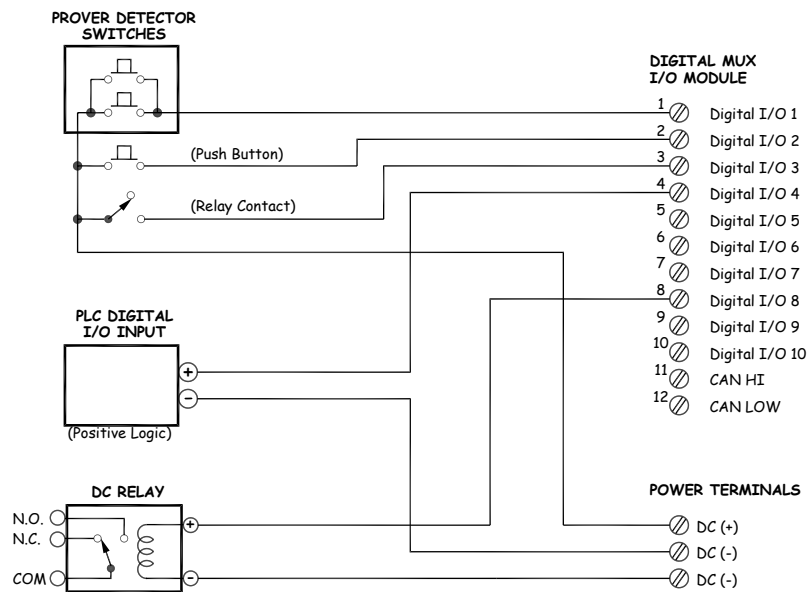

Figure 3-19: Example DM Module Wiring

3.7.2 Digital I/O Terminal Board

The Digital I/O Terminal (DT) board communicates with the DM module to provide 16 additional digital inputs or outputs to the flow computer.

Each Digital I/O point may be independently configured as an input or output through OMNICONNECT software. All digital points are referenced to the DC return of the DT board.

Figure 3-20 illustrates a wiring connection example for the DT board. Always use your project specific drawings for wiring the DT Board.

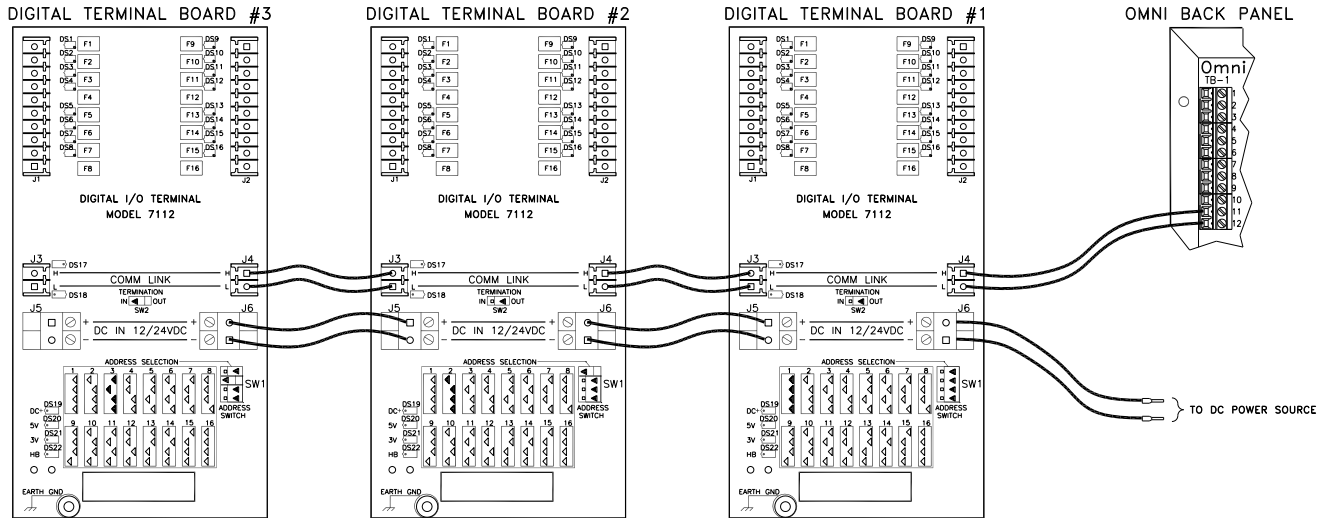

Figure 3-20: Example DT Board Wiring

In this example:

- J1 and J2 provide the 16 additional field device inputs or outputs.
- J3 provides the communications connection to a second DT board.
- J4 provides the communications connection to the flow computer back panel.
- J5 connects the power source to the second board.
- J6 connects to a DC power source.

This configuration allows for a series of DT boards that provide additional inputs and outputs.

To connect cables from the DT board to the DM module, follow these instructions and your project-specific drawings:

- 1.** Verify that power to the flow computer is **OFF**.
- 2.** If you are using an external DC power source, verify that the source is 12 to 24 voltage direct current (VDC).
- 3.** Connect wiring from the J1 and J2 pinouts to field devices according to your project-specific drawings.

Table 3-3 provides guidance for back panel wiring.

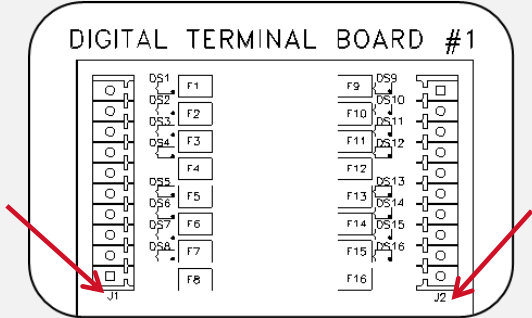
- 4.** Install cable wiring from the **J3** or **J4** pinouts on the DT board to pins **11** and **12** of **TB-1**(DM module) on the flow computer back panel.



- 5.** Install the power wiring from the **J5** or **J6** pinouts on the DT board to the external DC power source or the OMNI 4000 (TB-5) or 7000 (TB-11)back panel.

Table 3-4 provides guidance for back panel wiring.

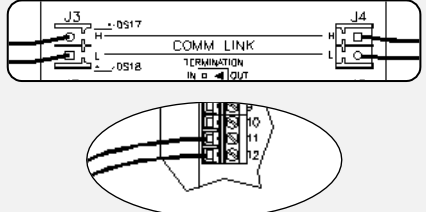
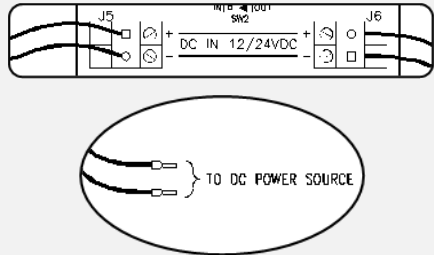

Table 3-3: DT Board Back Panel Wiring for Field Devices

J1 Pinouts	Signal Name	Signal Type
1	Digital 1	Digital I/O
2	Digital 2	Digital I/O
3	Digital 3	Digital I/O
4	Digital 4	Digital I/O
5	Return	Signal Return
6	Digital 5	Digital I/O
7	Digital 6	Digital I/O
8	Digital 7	Digital I/O
9	Digital 8	Digital I/O
10	Return	Signal Return
J2 Pinouts	Signal Name	Signal Type
11	Digital 9	Digital I/O
12	Digital 10	Digital I/O
13	Digital 11	Digital I/O
14	Digital 12	Digital I/O
15	Return	Signal Return
16	Digital 13	Digital I/O
17	Digital 14	Digital I/O
18	Digital 15	Digital I/O
19	Digital 16	Digital I/O
20	Return	Signal Return

Table 3-4: Back Panel Wiring for Communication and Power

DT board Connections	Pinouts	Signal Name	Back Panel Terminal Pin
J3 and J4 for communication	H	DT Comm Link H	DM 11 (TB1)
	L	DT Comm Link L	DM 12 (TB1)
J5 and J6 for power	+	12/24 VDC	TB-11 DC+ for the OMNI 7000 TB-5 for the OMNI 4000
	-	DC Return	TB-11 DC-

3.7.3 Dual Ethernet Module

Use either the factory-supplied Ethernet pigtail cables attached to the back panel or the RJ-45 jacks located on the DE module to connect network devices.



CAUTION: Do not pull the Ethernet pigtail cable wire pairs apart. This may result in signal loss and loss of communication.

When connecting the network devices to a DE module, follow these instructions for safe installation and operation:

1. For projects requiring both:
 - The NEMA chassis
 - A 100 Mb operating rate

Connect network cables to the **NET1** and/or **NET 2 RJ45** jacks on the DE module.



- For all other types of projects, complete the steps 2 through 5.
2. Check the end of the cable that is connected to the back-panel terminal blocks for the DE module.
3. Verify that the positive (+) and negative (-) wires for the transmit (TX) and receive (RX) lines:
 - a. Remain twisted together.
 - b. Are as close to the terminal contacts as possible.
4. Connect wiring from the OMNI 4000/7000 back panel pinouts to the network devices according to your project-specific drawings. Table 3-5 provides guidance for back panel wiring.
5. Connect wiring from the OMNI 4000/7000 back panel pinouts to the serial devices according to your project-specific drawings. Table 3-5 provides guidance for back panel wiring.

Table 3-5: Back Panel Wiring of the DE Module

Pinouts	Signal Name	Signal Type	Ethernet Pigtail Wire Color
1	Net #1 TX-	Ethernet TX-	Orange/White
2	Net #1 TX+	Ethernet TX+	White/Orange
3	RS485 Port 1–B	RS485 B	
4	RS485 Port 1–A	RS485 A	
5	Net #1 RX-	Ethernet RX-	Green/White
6	Net #1 RX+	Ethernet RX+	White/Green
7	Net #2 TX-	Ethernet TX-	Orange/White
8	Net #2 TX+	Ethernet TX+	White/Orange
9	RS485 Port 2–B	RS485 B	
10	RS485 Port 2–A	RS485 A	
11	Net #2 RX-	Ethernet RX-	Green/White
12	Net #2 RX+	Ethernet RX+	White/Green

3.7.4 Serial Module

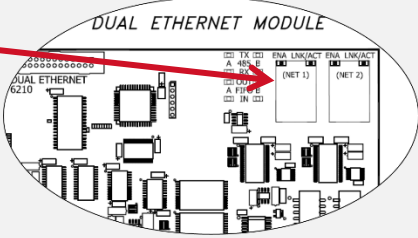
The Serial module provides two ports. By factory default, both ports are configured for RS-232 mode. Project-specific requirements may call for using the RS-485 2-wire or RS-485 4-wire mode.



The maximum number of devices connected in parallel for each port are:

- 12 compatible serial devices, including flow computers when using the OMNI 4000/7000 RS-232 serial ports.
- 32 devices when using the RS-485 mode.

Jumper blocks allow for independent selection of each port to operate in RS-232 or RS-485 mode. **Error! Reference source not found.** illustrates the factory-configured jumper settings for RS-232 wire at Port 1 and Port 2.

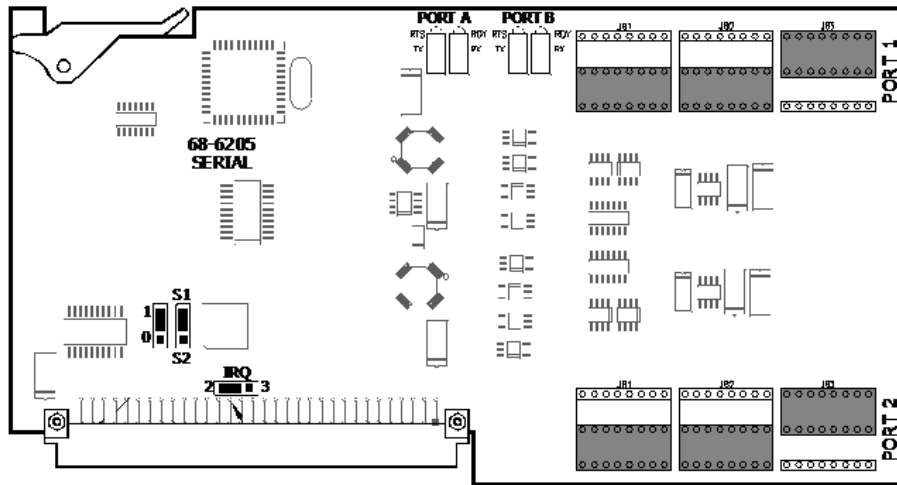

Figure 3-21: Serial Module Factory-configured for RS-232

If you are using the factory default (RS-232) mode for both ports, continue to the Connecting RS-232 Serial Devices section of this manual.

If you are using RS-485 2 or 4-wire mode, go to the Appendix A, A.1 to configure for RS-485 mode.

Connecting RS-232 Serial Devices

A maximum of three S modules can be installed in the OMNI 4000/7000 for a total of six serial ports. When connecting the cables from the serial devices to a serial port on the back panel, follow these instructions for safe installation and operation:

1. Determine which device to connect to each serial port.
2. Connect a cable from the selected port on the serial module to the selected electronic device.
3. For a single flow computer or the first flow computer in a series, jumper **Pin 1** and **Pin 2** together.

The RS-232 pull-down termination is on Pin 2 on the terminal block.

Table 3-6 provides guidance for back panel wiring.



The internal resistor on Pin 2 allows the RS-232C port to be tri-stated so that any noise generated on the line during idle communications is suppressed and not processed as data.

Table 3-6: Back Panel Wiring of the Serial Module

Pinouts	Signal Name			Signal Type
	RS-232	RS-485 2-Wire	RS-485 4-Wire	
1	TX	B	TX-B	RS232 or RS485–Port 1
2	TERM	–	–	RS232 pull-down termination–Port 1
3	RX	–	RX-B	RS232 or RS485–Port 1
4	GND	GND	GND	Signal Ground–Port 1
5	RTS	A	TX-A	RS232 or RS485–Port 1
6	RDY	–	RX-A	RS232 or RS485–Port 1
7	TX	B	TX-B	RS232 or RS485–Port 2
8	TERM	–	–	RS232 pull-down termination–Port 2
9	RX	–	RX-B	RS232 or RS485–Port 2
10	GND	GND	GND	Signal Ground–Port 2
11	RTS	A	TX-A	RS232 or RS485–Port 2
12	RDY	–	RX-A	RS232 or RS485–Port 2

Figure 3-22 through Figure 3-25 are examples of Serial module wiring. Always use your project specific drawings when wiring Serial modules to field devices.

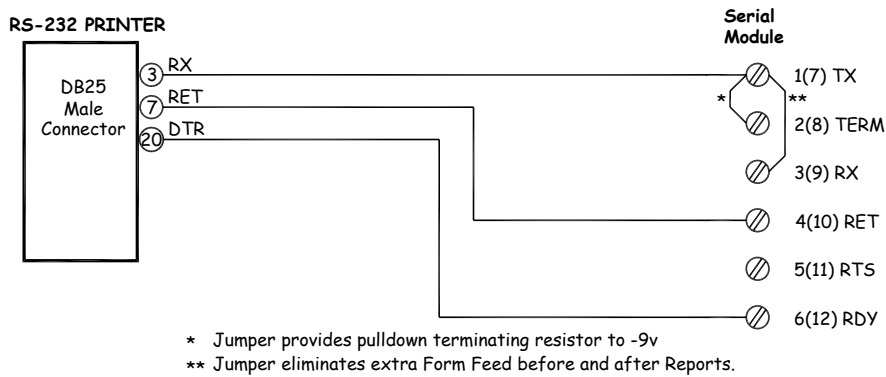

Figure 3-22: Example Serial Module Wiring to a Printer

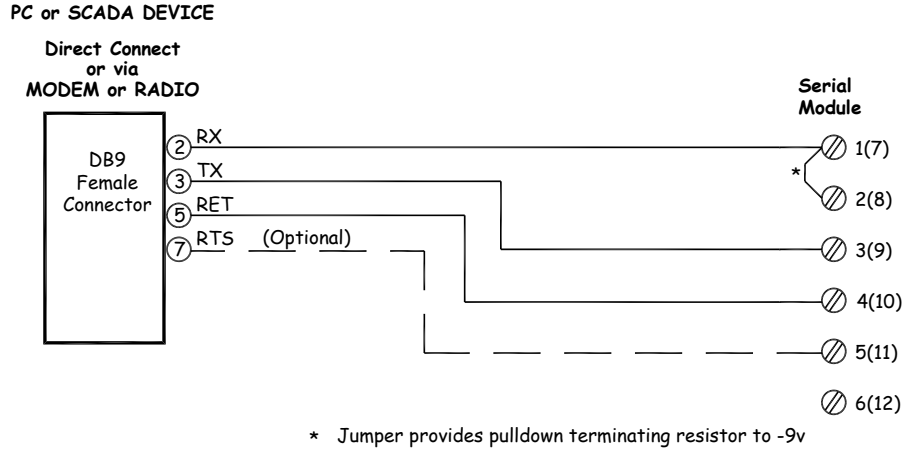

Figure 3-23: Example Serial Module Wiring to a PC or SCADA Device

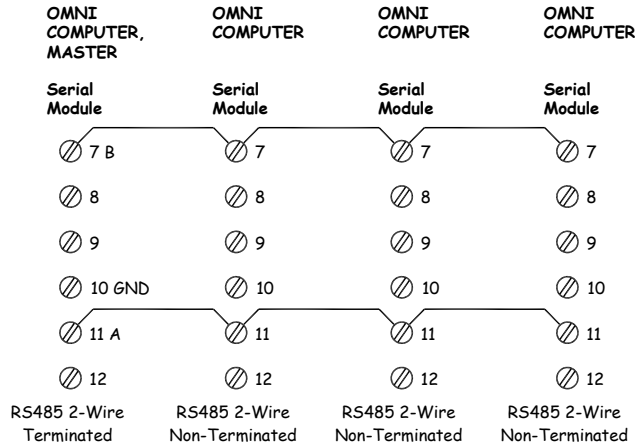

Figure 3-24: Example Peer to Peer Wiring of Serial Modules

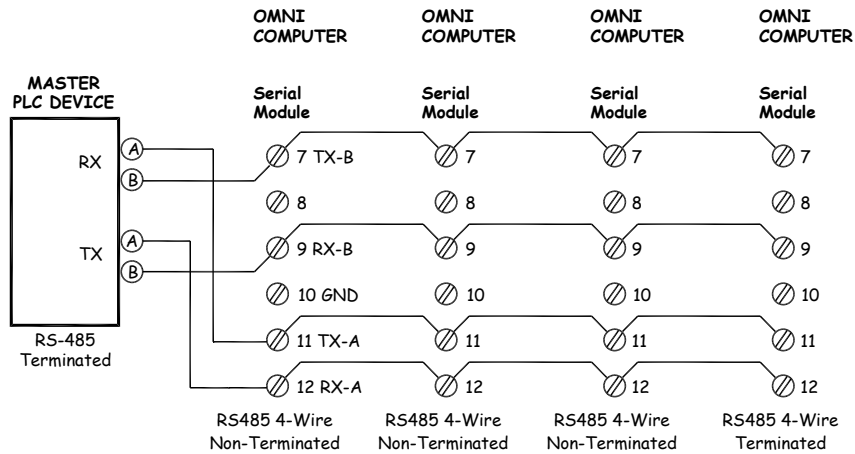

Figure 3-25: Example of Peer to Peer Wiring to a PLC Device

3.7.5 Process I/O Modules

The Process I/O modules are factory-installed in the following order:

- A module
- B module
- E/D module
- E module
- HT module (single transmitter)
- HM module (multiple drop mode transmitter)

The HT/HM HART module is used to interface to HART devices using the HART FSK protocol. The module has four independent HART FSK networks along with two analog outputs. The HT module is used for point to point communications and can support four single variable devices per network. The HM Module is used for multi-drop configurations or multi-variable sensors.



The flow computer can handle up to six HT/HM modules.

Refer to the Technical Bulletin 090003 (52-0000-0019) for additional information on the HT/HM modules.

The Process I/O modules are installed in the chassis and are connected to the back panel terminal block with 12 wires on an internal ribbon cable.



CAUTION:

- Use 4-wire Resistance Temperature Detectors (RTDs) when connecting to a Process I/O module's back panel terminal block.
- 2- or 3-wire RTDs may result in less accurate measurement or possible signal loss.



CAUTION: Always follow the OMNI factory module order. Each terminal block corresponds to an I/O module slot on the motherboard. If the order of the modules is modified, the reference to the terminal blocks will be altered.

Refer to the standard drawings that were supplied with the flow computer to determine the factory default input settings. If different settings are required, go to Section 7 Troubleshooting for installation troubleshooting.

Connect wiring from the back-panel terminal pinouts to field devices according to project-specific drawings. Table 3-7 provides guidance for back panel wiring.

Table 3-7: Back Panel Wiring for Process I/O Modules

Pinouts	Signal Name	Signal Type
A Module		
1	Input Channel #1	1-5 V, 4-20 mA or RTD
2	Input Channel #1	Isolated Signal Return
3	Input Channel #2	1-5 V, 4-20 mA or RTD
4	Input Channel #2	Isolated Signal Return
5	Input Channel #3	1-5 V, 4-20 mA or DC Coupled Flowmeter Pulses
6	Input Channel #3	Isolated Signal Return
7	Input Channel #4	1-5 V, 4-20 mA, or AC or DC Coupled Flowmeter Pulses
8	Input Channel #4	Isolated Signal Return
9	RTD Excitation Current Source #1	3.45 mA Current Source
10	Signal Return Terminals 9, 11 and 12	Internally Connected to DC Power Return
11	Analog Output #1	4-20 mA
12	Analog Output #2 or RTD Excitation Source #2	4-20 mA or 3.45 mA Current Source (Go to A.3.1 for ANALOG OUT #2 jumper settings)
B Module		
1	Input Channel #1	1-5 V, 4-20 mA or RTD
2	Input Channel #1	Isolated Signal Return
3	Input Channel #2	1-5 V, 4-20 mA or RTD
4	Input Channel #2	Isolated Signal Return
5	Input Channel #3	1-5 V, 4-20 mA or DC Coupled Flowmeter Pulses
6	Input Channel #3	Isolated Signal Return
7	Input Channel #4	AC Coupled Densitometer Frequency
8	Input Channel #4	Isolated Signal Return
9	RTD Excitation Current Source #1	3.45 mA Current Source
10	Signal Return Terminals 9, 11 and 12	Internally Connected to DC Power Return

Pinouts	Signal Name	Signal Type
11	Analog Output #1	4-20 mA
12	RTD Excitation Current Source #2	3.45 mA Current Source
E/D Module		
1	Input Channel #1	1-5 V, 4-20 mA or RTD
2	Input Channel #1	Isolated Signal Return
3	Input Channel #2	1-5 V, 4-20 mA or RTD
4	Input Channel #2	Isolated Signal Return
5	Input Channel #3	AC or DC Coupled Digital Densitometer Pulses
6	Input Channel #4	AC or DC Coupled Digital Densitometer Pulses
7		— NOT USED —
8	RTD Excitation Current Source #2	3.45 mA Current Source
9	RTD Excitation Current Source #1	3.45 mA Current Source
10	Signal Return for Terminals 5, 6, 8, 9, 11 and 12	Internally Connected to DC Power Return
11	Analog Output #1	4-20 mA
12	Analog Output #2	4-20 mA
E Module		
1	Input Channel #1	1-5 V, 4-20 mA or RTD
2	Input Channel #1	Isolated Signal Return
3	Input Channel #2	1-5 V, 4-20 mA or RTD
4	Input Channel #2	Isolated Signal Return
5	Input Channel #3	AC or DC Coupled Flowmeter Pulses
6	Input Channel #4	AC or DC Coupled Flowmeter Pulses
7	Double Chronometry Detector Switch Input	Active Low
8	RTD Excitation Current Source #2	3.45 mA Current Source
9	RTD Excitation Current Source #1	3.45 mA Current Source
10	Signal Return for Terminals 5, 6, 7, 8, 9, 11 and 12	Internally Connected to DC Power Return

Pinouts	Signal Name	Signal Type
11	Analog Output #1	4-20 mA
12	Analog Output #2	4-20 mA
HT/HM Module		
1	HART Network 1+	HART Input +
2	HART Network 1-	HART Input -
3	HART Network 2+	HART Input +
4	HART Network 2-	HART Input -
5	HART Network 3+	HART Input +
6	HART Network 3-	HART Input -
7	HART Network 4+	HART Input +
8	HART Network 4-	HART Input -
9	Analog Outputs #1 and #2	Return (DC-)
10	Analog Outputs #1 and #2	Return (DC-)
11	Analog Output #1	4-20 mA
12	Analog Output #2	4-20 mA

Figure 3-26 through Figure 3-32 illustrate examples of wiring from Process I/O modules to field devices. Always use your project specific drawing for wiring Process I/O modules to field devices.

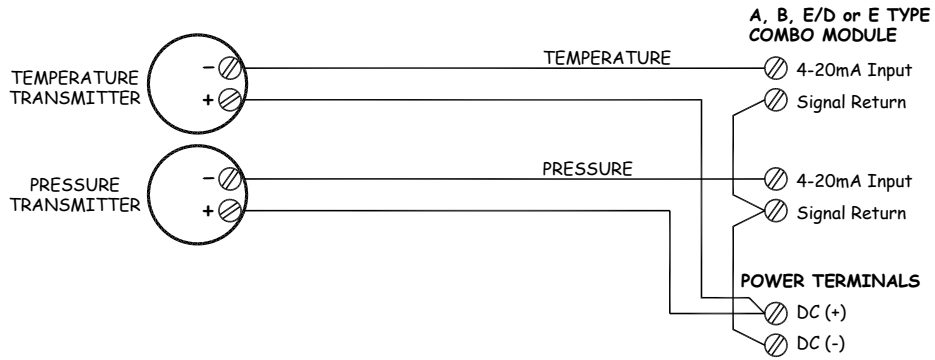

Figure 3-26: Example Process I/O Module Wiring to Transmitters

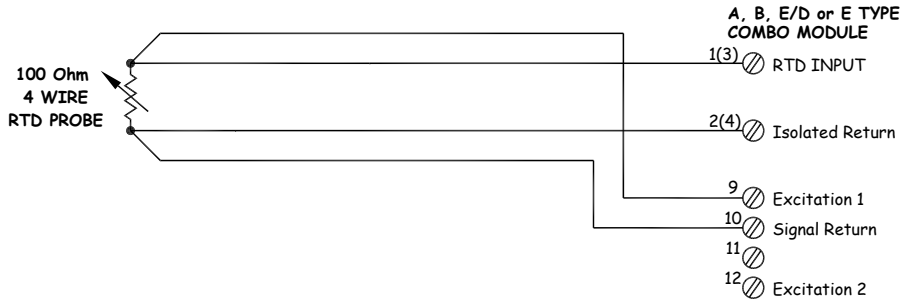

Figure 3-27: Example Process I/O Module Wiring to an RTD Probe

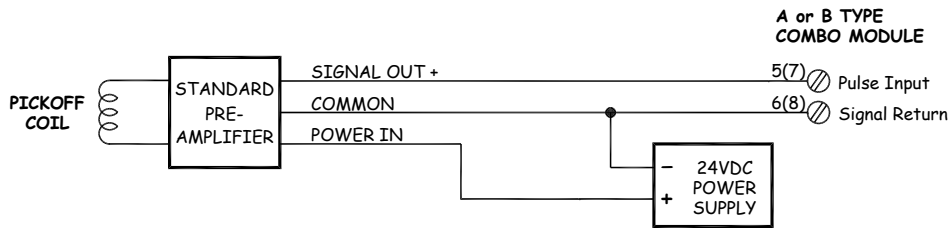

Figure 3-28: Example A or B Module Wiring to a Flowmeter

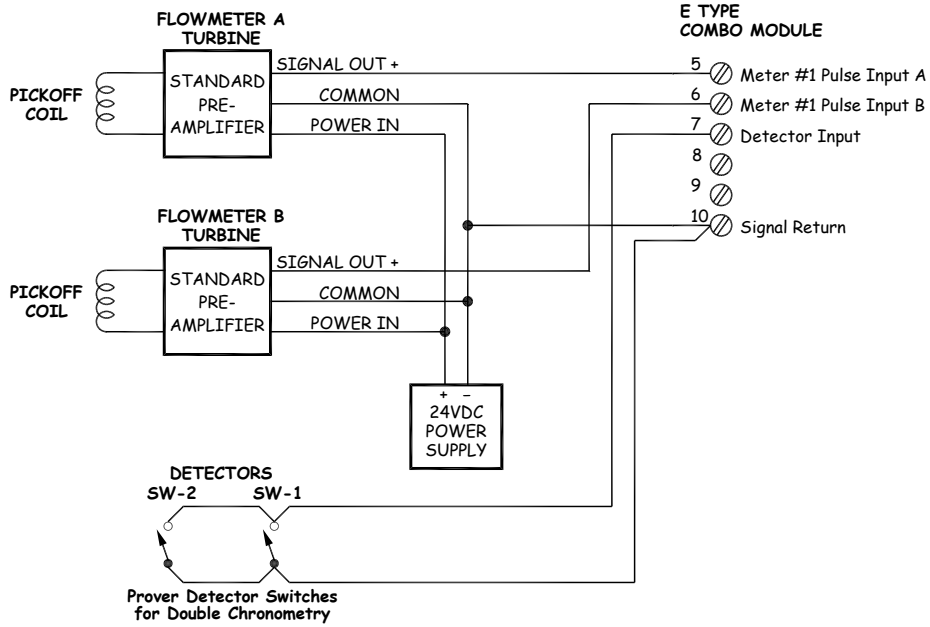

Figure 3-29: Example E Module Wiring to Flowmeters

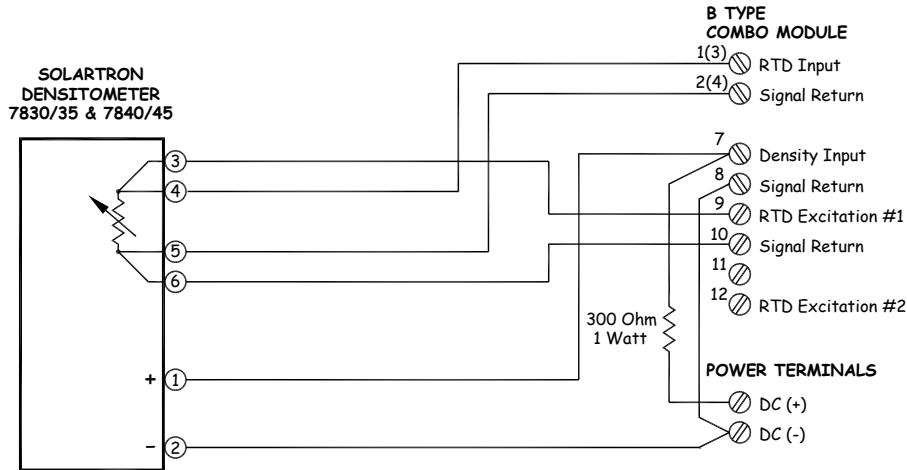

Figure 3-30: Example B Module Wiring to a Densitometer

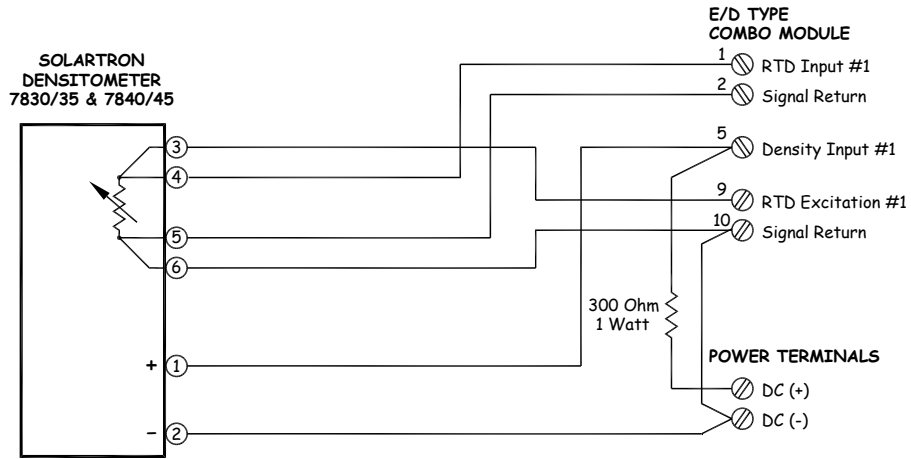

Figure 3-31: Example E/D Module Wiring to a Densitometer

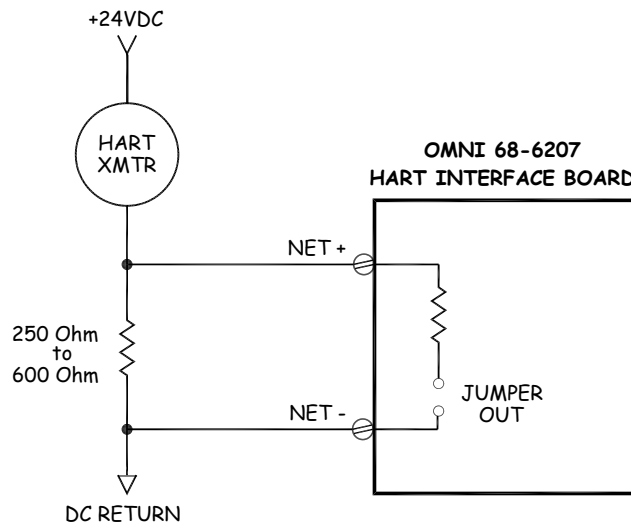

Figure 3-32: Example HART Module Wiring Using an External Load

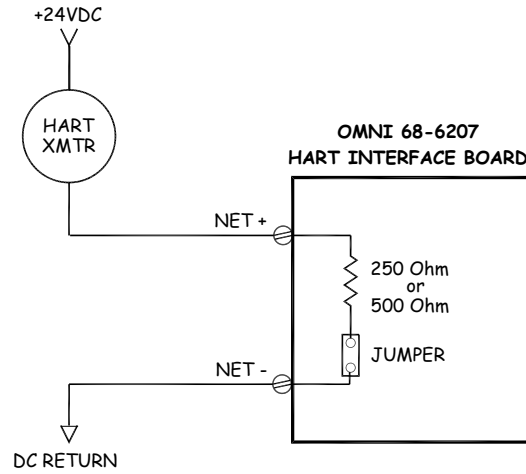

Figure 3-33: Example HART Module Wiring Using an Internal Load

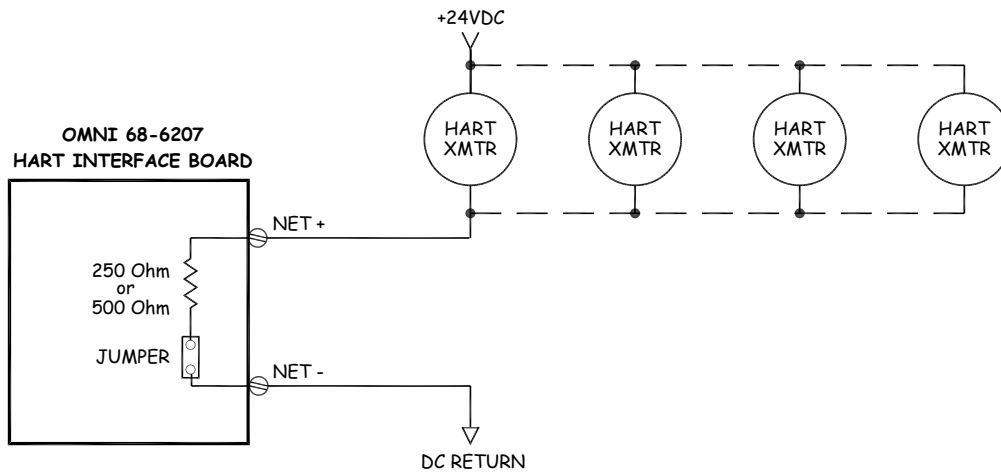

Figure 3-34: Example HART Module Wiring Using Multi Drop Load

3.8 Power the Flow Computer



Earth Ground Requirements:

Do not apply power before confirming that grounds are connected. Electrical shock can cause serious or fatal injury. Follow the National Electrical Code (NEC) and local codes for the safe installation of this equipment.



For the extended back panel, screw-type terminals are provided for AC and DC power.



All internal digital circuits within the flow computer are powered from a 5 V switching regulator module. If the 5 VDC supply is short-circuited, the supply will shut down and attempt to restart (Section 7).

3.8.1 AC Power

To connect AC power to the OMNI 4000/7000 flow computer back panel, use the factory-provided power cable and follow these instructions:



CAUTION: If a power cord other than the AC factory-provided cord is used, incorporate a readily accessible disconnect device that is external to the equipment and certified as being safe for the area.

1. Verify that the power supply meets these requirements:
 - 90 to 264 VAC
 - 47 to 440 Hz
2. Verify that the power cord includes a grounding pin.
3. Verify that the electrical outlet that will supply the power is grounded.
4. Connect the AC power cord to the power outlet on the back panel.

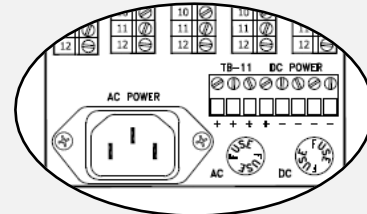

5. Connect the power cord to the grounded electrical outlet.
6. Start the power source.

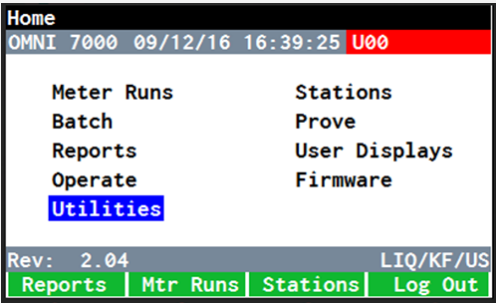
- | | | |
|----|---|--|
| 7. | Verify that the flow computer starts up and the front panel screen appears. |  |
| 8. | If you have accessed the flow computer and set the date and time (Section 4.1.3 Set the Date and Time), run Check Modules . (Section 4.2 Check Modules.) | |

3.8.2 DC Power

To connect the wiring from the DC power source to the OMNI 4000/7000 flow computer back panel, follow these instructions:

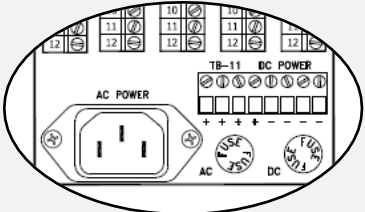
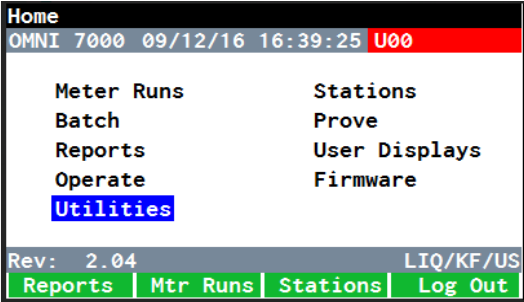
- | | | |
|----|---|---|
| 1. | Verify that the maximum voltage potential from DC positive (+) or DC negative (-) to the Earth Ground is less than 120 VDC. | |
| 2. | Verify that the power supply is 22 to 26 VDC. | |
| 3. | Connect the DC power wiring to the TB-11 positive (+) and negative (-) screw terminals. |  |
| 4. | Start the power source. | |
| 5. | Verify that the flow computer starts up and the front panel screen appears. |  |
| 6. | If you have accessed the flow computer and set the date and time (Section 4.1.3), run Check Modules (Section 4.2). | |

4. Configuration

4.1 Getting Started

4.1.1 Front Panel Navigation

The front panel of the OMNI 4000/7000 offers an informative display and simple controls for easy navigation (Figure 4-1 and Table 4-1). The front panel display provides quick access to commonly used functions.

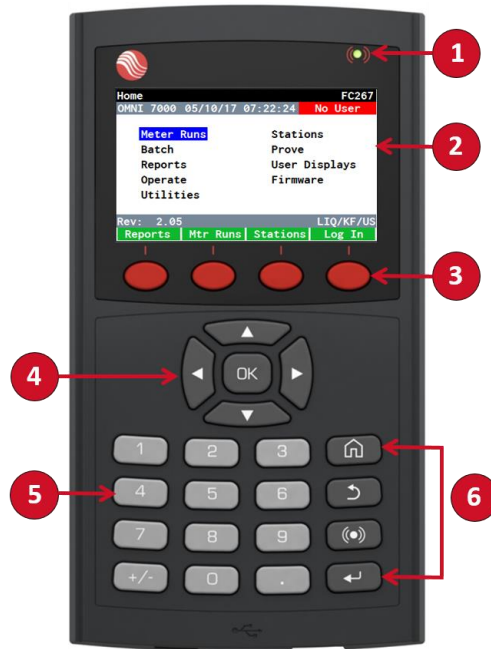





Figure 4-1: OMNI 4000/7000 Front Panel

Table 4-1: Front Panel Elements and Descriptions

Front Panel Element	Description
<p>1 Active Alarm LED</p>	<p>A new alarm causes this LED to glow red. After the alarm is acknowledged, the LED glows green. When the condition has cleared or there are no other alarm conditions, the LED extinguishes and has no color.</p> <p>The alarm activates for conditions and events such as printing. Event alarms that are displayed will clear automatically from the screen after the event has been acknowledged and as soon as the condition that caused the alarm is no longer active.</p>
<p>2 Color Display</p>	<p>The large color screen is continuously updated and provides access to information and basic functionality.</p>

Front Panel Element	Description
<p>3 Function Keypad</p>	<p>Each red function key activates the function appearing above it on the green function bar in the display. The function bar and function keys adapt as the menu changes.</p>
<p>4 Navigation Keypad</p>	<p>The arrow keys provide vertical and horizontal movement and scrolling.</p> <p>The OK key (same as Enter) confirms a selection or data input.</p>
<p>5 Numeric Keypad</p>	<p>These keys are used for numeric data entry.</p>
<p>6 Operational Keypad</p>	<p> The Home key takes you to the main starting screen.</p>
	<p> The Back key takes you to the previously displayed screen.</p>
	<p> The Alarm key takes you to the Active Alarms screen.</p>
	<p> The Enter key (same as OK) confirms a selection or data input.</p>

Display screens are organized in a hierarchy of menu items and detailed information screens. The Home screen, shown in Figure 4-2, is the default starting screen for navigation and can always be accessed by pressing the Home key on the front panel. Table 4-2 describes each element on the home screen and its function.

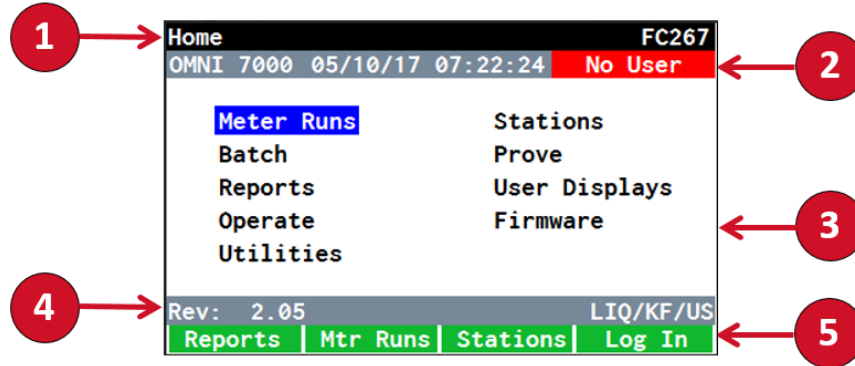

Figure 4-2: Home Screen

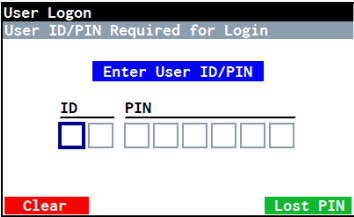
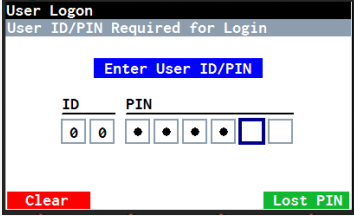
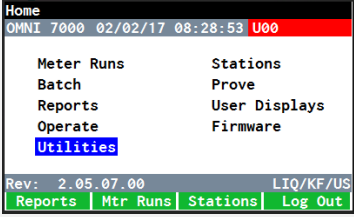

Table 4-2: Home Screen Elements and Descriptions

Home Screen Element	Description
1 Title Bar	The bar at the top of every screen displays the name of the current screen on the left. On the Home screen, the Computer ID configuration string is displayed on the right.
2 Auxiliary Bar	This bar displays OMNI 7000 (for the OMNI 4000 and OMNI 7000), the date, the time and the ID of the currently logged-in user or 'No User' if no one is logged in. When there are multiple screens for a particular category (such as Meter Runs), the auxiliary bar displays numbers that function like tabs in a browser. Use the navigation keypad to scroll left or right through each numbered screen.
3 Main Display	The large area in the center of the screen displays the main content. This could be a menu of options or detailed data. Use the navigation keypad and 'OK' to navigate within a screen and between screens.
4 Application Bar	This bar appears only on the Home screen. It displays the firmware revision number of the flow computer and the configured application mode, such as whether the flow computer is configured for liquid or gas, K-Factor or Meter Factor linearization and using Metric or U.S. units of measurement.
5 Function Bar	This bar labels the function keys directly below the display and updates as the screen changes. For many screens, the function bar simply provides shortcuts to several Home screen items, such as Meter Runs, Stations, Reports and Batch.

4.1.2 User Logon

Flow computers are shipped with one default front panel ID and PIN, which gives the Administrator full access to all functions and configuration items. The User Logon screen displays when editing any data.

To log on, follow these instructions:

1.	From the Home screen, press Log In .	
2.	On the User Logon screen, enter the default User ID: 00 using the numeric keypad.	
3.	Enter the default User Pin: 0000	
4.	<p>Press OK.</p> <p>This will send you back to the Home screen. Your User ID will show in the top right.</p>	
5.	Use the default Administrator User ID and Pin until OMNICONNECT is installed and activated on your system, and users have been created (Section 4.8 Security Setup)	
<div style="display: flex; align-items: flex-start;"> <div style="margin-right: 20px;">  </div> <div> <p>When editing any data:</p> <ul style="list-style-type: none"> • The User ID and PIN remains active for 15 minutes. • After 15 minutes, the User ID and PIN time out and need to be re-entered to continue editing data. • This default timeout can be modified after OMNICONNECT is installed and activated. </div> </div>		

4.1.3 Set the Date and Time



As a best practice, set the date and time first because they are used during system measurement and audit logging.

To set the date and time, follow these instructions:

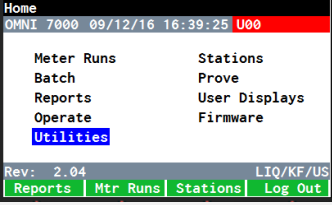
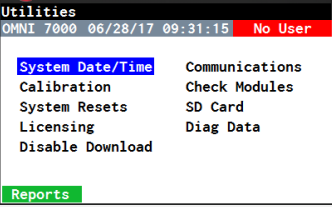
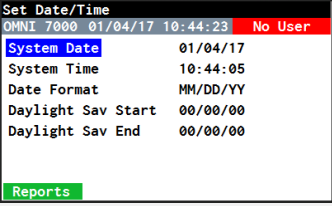
1.
 - a. From the **Home** screen on the front panel display, use the arrow navigation keys to go to and select **Utilities**.
 - b. Press the **OK** key.
2.
 - a. On the **Utilities** screen, navigate to the **System Date/Time** menu selection.
 - b. Press **OK**.
3. Use the arrow navigation keys to select a field. Press **OK** to activate the variable field for editing.
 
4. Use the **Numeric Keypad** to edit the numbers.

Use the **Right** and **Left** arrow keys, if needed, to navigate between the numbers to edit them.

For **Date Format** field, use the **Up** or **Down** arrow keys to select a format.

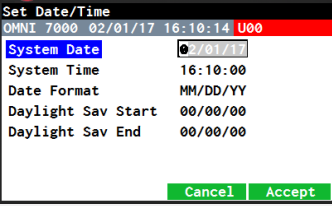
5. Press the **Accept** function key or **OK** to accept the edit, or the **Cancel** function key if the edit is not wanted.
6. Repeat these steps for the remaining fields.

When you are finished, press the **Back** key to return to the **Utilities** screen.



The date and time can also be set or edited from within OMNICONNECT after it is loaded on your system.

4.2 Check Modules

Complete the Check Modules procedure from the front panel so that the flow computer can properly allocate any changes to the hardware's I/O channels for later configuration and assignment using the OMNICONNECT software. To do so, follow these instructions:

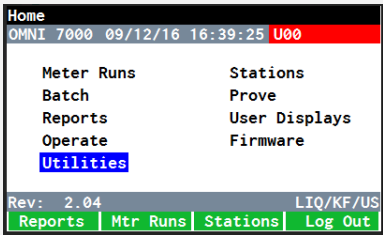
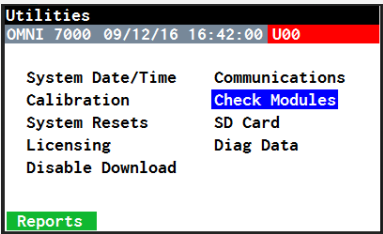
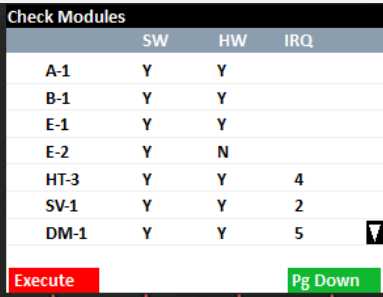
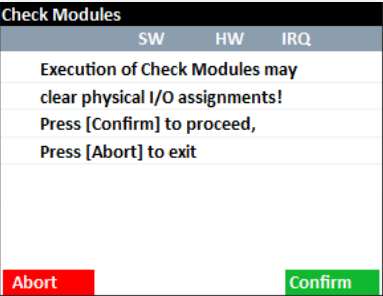
<p>1.</p>	<p>a. From the Home screen on the front panel display, use the arrow navigation keys to go to and select Utilities.</p> <p>b. Press OK.</p>																																	
<p>2.</p>	<p>a. On the Utilities screen, navigate to the Check Modules menu selection.</p> <p>b. Press OK or the Enter key.</p>																																	
<p>3.</p>	<p>a. Verify that the SW (Software) and HW (Hardware) columns both display Y (Yes) for each module.</p> <p>b. Use the Pg Down or Pg Up functions to scroll up or down the screen to view all the modules, as necessary.</p> <p>c. If the SW and HW columns display all Ys, then you are finished.</p> <p>d. If modules show N (No) under either the SW or HW columns, press the Execute function key.</p>	 <table border="1" data-bbox="1010 886 1390 1180"> <thead> <tr> <th></th> <th>SW</th> <th>HW</th> <th>IRQ</th> </tr> </thead> <tbody> <tr> <td>A-1</td> <td>Y</td> <td>Y</td> <td></td> </tr> <tr> <td>B-1</td> <td>Y</td> <td>Y</td> <td></td> </tr> <tr> <td>E-1</td> <td>Y</td> <td>Y</td> <td></td> </tr> <tr> <td>E-2</td> <td>Y</td> <td>N</td> <td></td> </tr> <tr> <td>HT-3</td> <td>Y</td> <td>Y</td> <td>4</td> </tr> <tr> <td>SV-1</td> <td>Y</td> <td>Y</td> <td>2</td> </tr> <tr> <td>DM-1</td> <td>Y</td> <td>Y</td> <td>5</td> </tr> </tbody> </table>		SW	HW	IRQ	A-1	Y	Y		B-1	Y	Y		E-1	Y	Y		E-2	Y	N		HT-3	Y	Y	4	SV-1	Y	Y	2	DM-1	Y	Y	5
	SW	HW	IRQ																															
A-1	Y	Y																																
B-1	Y	Y																																
E-1	Y	Y																																
E-2	Y	N																																
HT-3	Y	Y	4																															
SV-1	Y	Y	2																															
DM-1	Y	Y	5																															
<p>4.</p>	<p>Press the Confirm function key to proceed with the Check Modules command so that all installed modules show Y under both the SW and HW columns.</p>																																	

The flow computer detects any changes in the hardware modules installed.

Do not be concerned if not all of the modules show a value under the **IRQ** (Interrupt Request) column. The IRQ is fixed for some modules.

5.
 - a. Confirm that any modules that previously said **N** under the **SW** column now say **Y**, indicating that their software has been updated to reflect the hardware installation.
 - b. Confirm that any modules that previously showed **N** under the **HW** column no longer appear on the screen after the list has been updated, which indicates that the module has been removed.

Check Modules			
	SW	HW	IRQ
A-1	Y	Y	
B-1	Y	Y	
E-1	Y	Y	
HT-3	Y	Y	4
SV-1	Y	Y	2
DM-1	Y	Y	5
S-1	Y	Y	3

In this example, the **E-2 module** has been physically removed from the flow computer, and after performing the **Check Modules** function, it no longer appears in the module list.

6. When complete, press the **Back** key to return to the **Utilities** screen.

4.3 Configuring Communication Ports (Front Panel)

There are four protocols of communication for ports:

- Modbus Slave Mode – a serial protocol that respond to requests from Modbus Master devices.
- Modbus Master Mode – a protocol that process transactions reading or writing from various data types' Modbus slave devices.
- Peer to Peer Mode – a serial protocol that allows several computers to be multi-dropped in a seral network.
- Active Redundancy Mode – a serial protocol that allows a pair of flow computers to operate redundantly.

See Section 4.10.11 for configuring the flow computer in Peer to Peer or Active Redundancy Mode.

Connect the flow computer to a serial port or Ethernet port PC if you have Serial or Ethernet modules installed in the flow computer. You can alternately connect using the USB Mini-B port on the front panel or as a backup, use the USB port on the CPU.



Use the PC that will host the OMNICONNECT software. For Ethernet connections, the PC and flow computer need to be on the same network subnet if not communicating through a router. Contact your network administrator if you need help in determining the network address of the PC.

4.3.1 Configuring Serial Ports

The following selections are available from the front panel for serial ports located on the Serial modules or Ethernet modules. Not all serial port selections shown here will appear on the screen, as it depends on what Serial or Ethernet modules are installed on the flow computer:

- Serial (S) Module 1 for RS-232 or RS-485 ports 1 and 2 on the S-1 module
- Serial (S) Module 2 for RS-232 or RS-485 ports 3 and 4 on the S-2 module
- Serial (S) Module 3 for RS-232 or RS-485 ports 5 and 6 on the S-3 module
- Ethernet (DE) Module 1 for RS-485 2-wire ports 7 and 8
- Ethernet (DE) Module 2 for RS-485 2-wire ports 9 and 10

To access serial ports, follow these instructions:

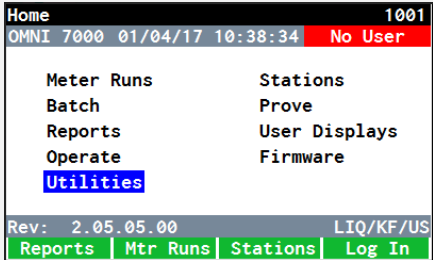
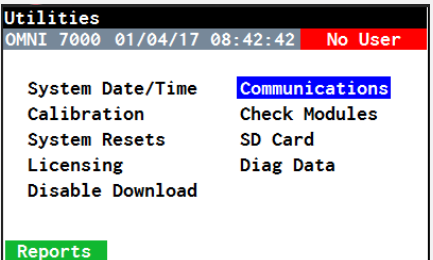
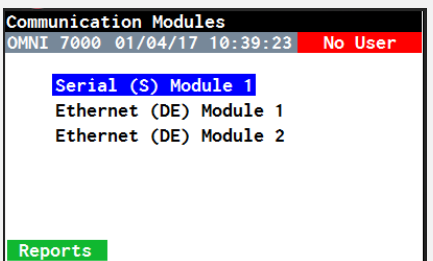
<p>1.</p>	<p>From the Home screen, select Utilities, and then press OK.</p>	 <p>The screenshot shows the Home screen with the following text: Home 1001, OMNI 7000 01/04/17 10:38:34 No User. The menu items are: Meter Runs, Stations, Batch, Prove, Reports, User Displays, Operate, Firmware, and Utilities (highlighted in blue). At the bottom, it shows Rev: 2.05.05.00 and LIQ/KF/US, with a green bar containing Reports, Mtr Runs, Stations, and Log In.</p>
<p>2.</p>	<p>On the Utilities screen, select Communications and press OK.</p>	 <p>The screenshot shows the Utilities screen with the following text: Utilities, OMNI 7000 01/04/17 08:42:42 No User. The menu items are: System Date/Time, Communications (highlighted in blue), Calibration, Check Modules, System Resets, SD Card, Licensing, Diag Data, and Disable Download. At the bottom, there is a green bar with Reports.</p>
<p>3.</p>	<p>a. Select the module you want to edit (Serial or Ethernet) and press OK. b. If your flow computer includes an Ethernet Module, go to Step 3. If it does not, go to Step 4.</p>	 <p>The screenshot shows the Communication Modules screen with the following text: Communication Modules, OMNI 7000 01/04/17 10:39:23 No User. The menu items are: Serial (S) Module 1 (highlighted in blue), Ethernet (DE) Module 1, and Ethernet (DE) Module 2. At the bottom, there is a green bar with Reports.</p>

4. To access Serial Ports on the Ethernet Modules, one additional step is needed:

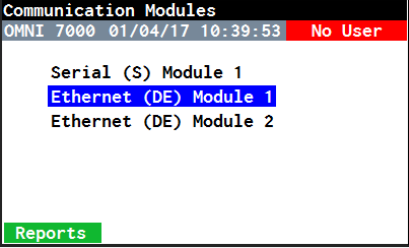
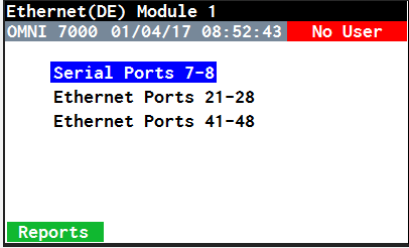
 - a. Select the **Ethernet Module** you want to edit and press **OK**.
 - b. Select the **Serial Port** (not the Ethernet port) to edit and press **OK**.
- 

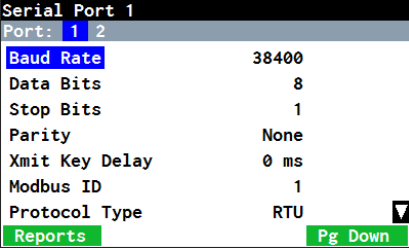
5. Use the **Up** and **Down** arrow keys to navigate to the required settings. Press **OK** or **Enter** to activate the field for editing.

Contact your IT or Network Administrator for help with your COM port parameters to whatever serial device is being connected to the flow computer.
- 
6. a. Use the **Up** and **Down** arrow keys to select the option that matches the communication parameters on the flow computer to your PC COM port.

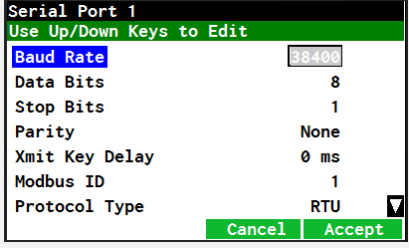
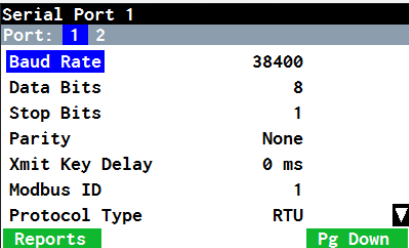
b. Press **OK** or **Accept** to accept the changes before moving to the next setting.

Use the Numeric Keypad to update the Modbus ID.
- 
7. Use the **Pg Up** and **Pg Down** function key to navigate to all settings.
- 
8. After the settings have been configured, verify that the serial cable is correctly installed (Section 3.7.4 Serial Module).

4.3.2 Configuring Ethernet Ports

Initially, every OMNI 4000/7000 flow computer will appear with these default IP addresses:

- 10.0.0.1 for Ethernet Port 1
- 10.0.0.2 for Ethernet Port 2 (of each Dual Ethernet [DE] module installed)

You must change this IP address to one that is unique and appropriate for your network, especially if you have multiple OMNI flow computers installed.



Use a valid IP Address and NetMask combination; for example, 10. 10. 90.250 and 255.255.0.0. Check with your Network Administrator for more details about IP addresses.

Unlike Serial ports, Ethernet ports are only accessible through Ethernet modules. The following selections are available from the front panel for Ethernet ports located on the Ethernet modules:

- Ethernet (DE) Module 1 for ports 21-28
- Ethernet (DE) Module 1 for ports 41-48
- Ethernet (DE) Module 2 for ports 61-68
- Ethernet (DE) Module 2 for ports 81-88

Not all of these Ethernet port selections will appear on the screen, as this is dependent on what Ethernet modules are installed in the flow computer.

To configure an Ethernet port, follow these instructions:

<p>1. From the Home screen, select Utilities, and then press OK.</p>	<p>The screenshot shows the Home screen with the following text: Home 1001, OMNI 7000 01/04/17 10:38:34 No User. The menu items are: Meter Runs, Stations, Batch, Prove, Reports, User Displays, Operate, Firmware, and Utilities (highlighted in blue). At the bottom, there is a status bar with Rev: 2.05.05.00, LIQ/KF/US, and a row of buttons: Reports, Mtr Runs, Stations, and Log In.</p>
<p>2. On the Utilities screen, select Communications and press OK.</p>	<p>The screenshot shows the Utilities screen with the following text: Utilities, OMNI 7000 01/04/17 08:42:42 No User. The menu items are: System Date/Time, Communications (highlighted in blue), Calibration, Check Modules, System Resets, SD Card, Licensing, Diag Data, and Disable Download. At the bottom, there is a Reports button.</p>

3. Scroll to select **Ethernet (DE) Module**, and then press **OK**.

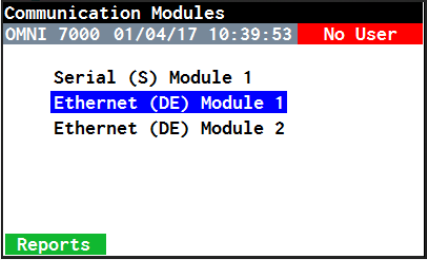

The screenshot shows a terminal window titled "Communication Modules" with the header "OMNI 7000 01/04/17 10:39:53 No User". The menu items are "Serial (S) Module 1", "Ethernet (DE) Module 1" (highlighted in blue), and "Ethernet (DE) Module 2". A green "Reports" button is at the bottom.

4. On the **Ethernet (DE) Module** screen, scroll to select the appropriate Ethernet port (not the Serial ports), and then press **OK**.

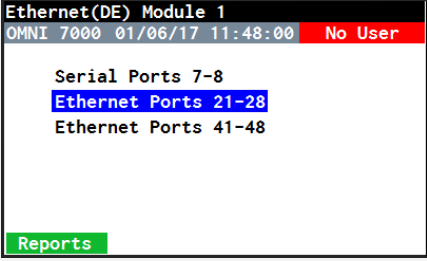

The screenshot shows a terminal window titled "Ethernet(DE) Module 1" with the header "OMNI 7000 01/06/17 11:48:00 No User". The menu items are "Serial Ports 7-8", "Ethernet Ports 21-28" (highlighted in blue), and "Ethernet Ports 41-48". A green "Reports" button is at the bottom.

5.

 - a. On the **DE Network Ports** screen, with the **IP Address** selected, press **OK** to activate the field.
 - b. Use the numeric keypad to enter your desired IP address.
 - c. Use the right and left arrow key to navigate between the numbers to edit them.
 - d. Press **OK** or **Accept** to accept the changes before moving to the next setting.

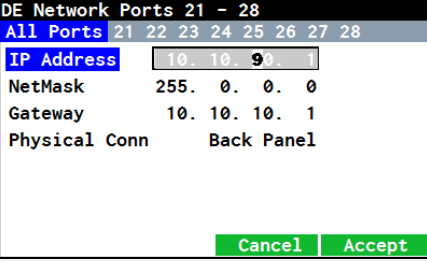

The screenshot shows a terminal window titled "DE Network Ports 21 - 28" with the header "All Ports 21 22 23 24 25 26 27 28". The "IP Address" field is highlighted in blue and contains "10.10.9.1". Other fields include "NetMask 255.0.0.0", "Gateway 10.10.10.1", and "Physical Conn Back Panel". "Cancel" and "Accept" buttons are at the bottom.

-  If the IP address has less than three digits, press the arrow key on the first digit placeholder.

6. Use the **Pg Up** and **Pg Down** function key to navigate to all settings.

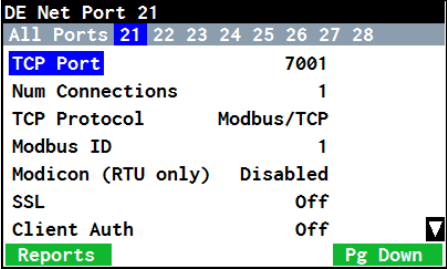

The screenshot shows a terminal window titled "DE Net Port 21" with the header "All Ports 21 22 23 24 25 26 27 28". The "TCP Port" field is highlighted in blue and contains "7001". Other settings include "Num Connections 1", "TCP Protocol Modbus/TCP", "Modbus ID 1", "Modicon (RTU only) Disabled", "SSL Off", and "Client Auth Off". "Reports" and "Pg Down" buttons are at the bottom.

7. Press the **Right Arrow** navigation key to verify the setup for each port, including protocol. When you set up an OMNICONNECT site, the settings must match the settings in this flow computer (Section 4.7.2 Setup Sites).

By default, Port 21 is assigned a TCP/IP port of 7001, Port 22 a TCP/IP port of 7002, and so on. These can be changed to suit your requirements, as well the Modbus port numbers.

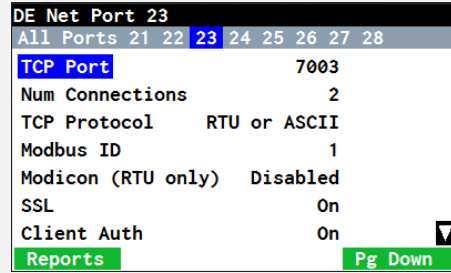

8. After the settings have been configured, verify that the Ethernet cable is correctly installed (Section 3.7.3 Dual Ethernet Module).

4.3.3 Communicate using a USB Port

To access a USB port, the quickest way to connect the flow computer to your PC, follow these instructions:

1. Locate the right-most USB Mini-B (5-pin) port on the front panel of the flow computer.

On the front panel, the left-most USB port is a USB A-Type port that is only used for flashing with a memory stick; it is not for communicating with OMNICONNECT. The CPU provides a port to use for OMNICONNECT communications and firmware upgrades.



2. Use a USB cable to connect the USB Mini-B and the PC.

4.4 Software Installation

Follow these instructions to install the OMNICONNECT software onto your PC:

1. Insert the OMNI USB Key that was packaged with the flow computer into the USB port in the PC.

If you do not have the OMNI USB Key, contact the OMNI Help Desk at helpdesk@omniflow.com or call 281-240-6161.

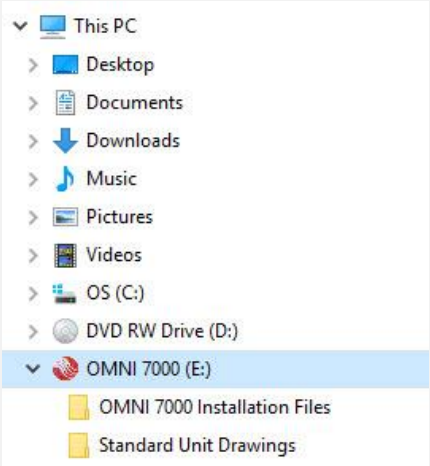



The OMNI USB Key includes the following materials and applications:

- Installation files for OMNICONNECT, OMNIPANEL, MBT and Network Utility
- Help files
- Standard drawings
- Data retrieval documents
- Modbus mapping documents (to show database register differences between the Omni 3000/6000 and Omni 4000/7000)



2. Click on **Install OMNICONNECT**.



3.	Double-click the autorun.exe file to install the program.
4.	When prompted, click on Install OMNICONNECT .
5.	Follow the on-screen instructions to complete the software installation process.

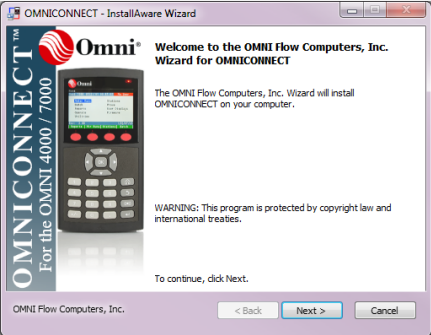

4.5 OMNICONNECT™ License Activation



OMNICONNECT requires a license activation. The license stays connected to the PC used for activation. For Corporate licenses, one license could be used for one or more OMNICONNECT activations.

OMNICONNECT offers three different methods of activating the software license: online, manual, and phone activation.

- Use the online activation to activate the license(s) from OMNI's License Server when using a PC connected to the internet.
- Use the manual activation to activate OMNICONNECT to a PC not connected to the internet (offline). You need to use a PC connected to the internet to transfer the license to the offline PC that will host the OMNICONNECT license.
- When there is no internet connection, use the phone activation to activate OMNICONNECT license by exchanging activation codes with OMNI Help Desk.

To activate the OMNICONNECT license, follow the applicable instruction set in this section.

4.5.1 Welcome Email

When you initially purchase OMNICONNECT, you will receive a welcome email with the following information:

1. License ID
2. Password
3. Registered company name
4. Registered contact email
5. Number of activations available

Keep this information readily available to use during the activation process, and securely store it for future use.



The license owner is responsible for securing license details. Misuse may cause a loss of license(s).

4.5.2 Online Activation

Follow these instructions to activate your license online:

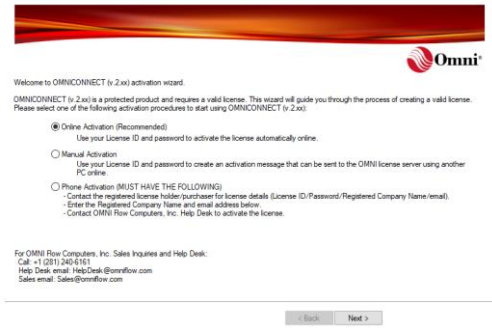
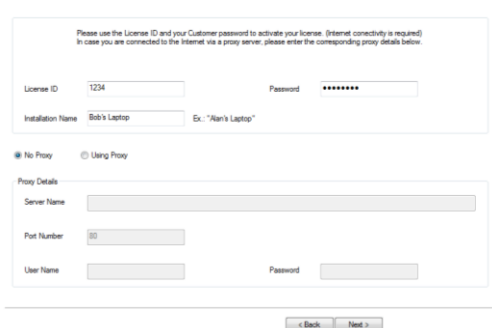
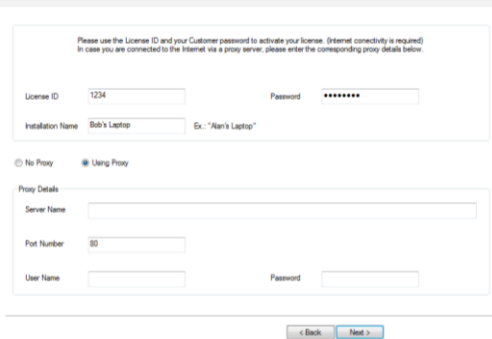
1.	<p>Launch OMNICONNECT 7000.</p> <p>This brings up the OMNICONNECT License Activation Wizard Start Page.</p>	
2.	<p>Select Online Activation and click Next to open the online activation screen.</p>	
3.	<p>Enter the License ID and Password from the welcome email (Section 4.5.1 Welcome Email)</p> <p>Enter the Installation Name, such as the 'user's name laptop' for customer reference.</p> <p>If you are using a proxy server, proceed to Step 4. Otherwise, go to Step 5.</p>	
4.	<p>If using a proxy server, select Using Proxy and complete the corresponding Proxy Details fields.</p> <div style="border: 2px solid #0070C0; border-radius: 15px; padding: 10px; margin: 10px 0;"> <p>Contact your network administrator for proxy information. This wizard supports only plain text proxy servers.</p> </div>	
5.	<p>Click Next.</p>	

6. If the OMNICONNECT successfully activated, a final screen will appear and show a summary of the license activation. Click **Finish**, and start using OMNICONNECT.

If you receive the error screen illustrated to the right:

- a. Click **OK**.
- b. Contact your IT Service Department and request access to the OMNI License Server (<https://licsvr.omniflow.com>).
- c. Once your IT Service Department has given you access, click **Next** again to resubmit the activation request.

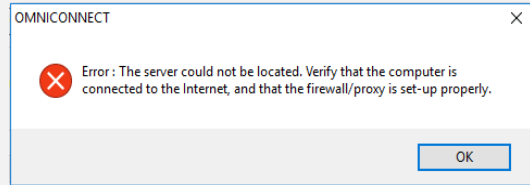
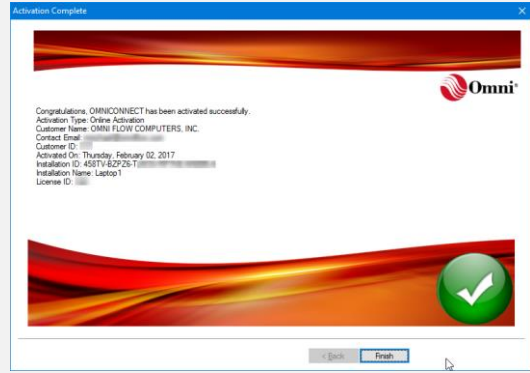

4.5.3 Manual Activation

You can manually activate your license by submitting an activation request using another PC connected to the Internet and transfer an activation code back to OMNICONNECT. Follow these instructions to activate your license manually:

1. Launch OMNICONNECT 7000 on the offline PC.

This brings up the OMNICONNECT License Activation Wizard Start Page.

2. Select **Manual Activation** to open the manual activation screen and click **Next**.

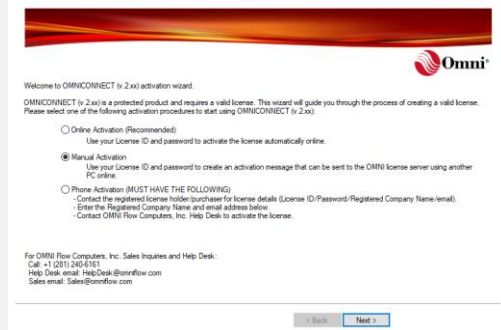

3. In the **Manual Activation** screen, Step 1, enter the License ID and Password (from the Welcome email, Section 4.5.1).

Enter the **Installation Name**, such as the 'user's name PC' for customer reference.



4. Click **Generate Request**.

This will generate a message in Step 2 in the **Activation Request** box.

Do not close this dialog or navigate back during the activation process. A submitted activation request must match the retrieved activation code.

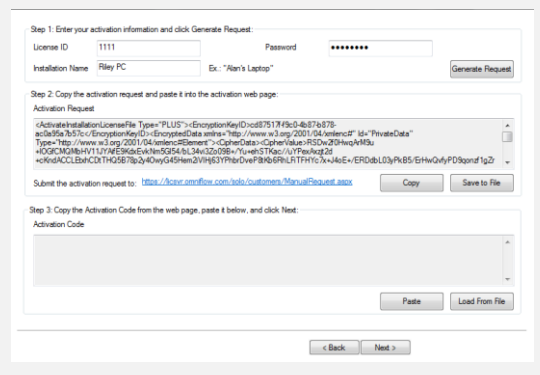

5. Click **Copy** to copy the activation request or click **Save to File** to save the request as a file.

Transfer the activation request and the OMNI URL <https://licsvr.omniflow.com/solo/customers/ManualRequest.aspx> to an online PC.

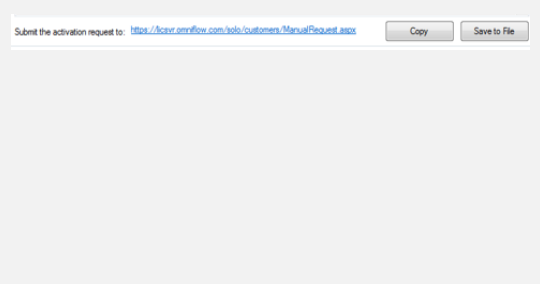

6. At the online PC, open an internet browser and navigate to the URL to access the OMNI license server (OLS).



7. At the **Manual Request** screen on the OMNI customer service site, follow the instructions under **Copy and Paste Request** or **Upload Request File** if you saved a file.

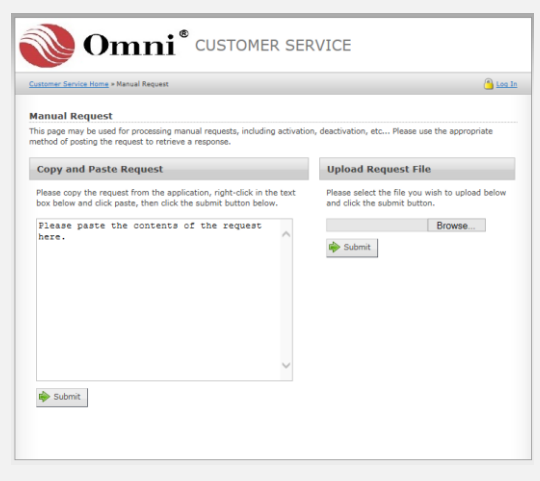

8. In the next screen, **Response**, follow the instructions on the page.

Depending on your browser, you may need to highlight a line of text before selecting all and copying.

If you uploaded a file, follow the alternative download instructions.

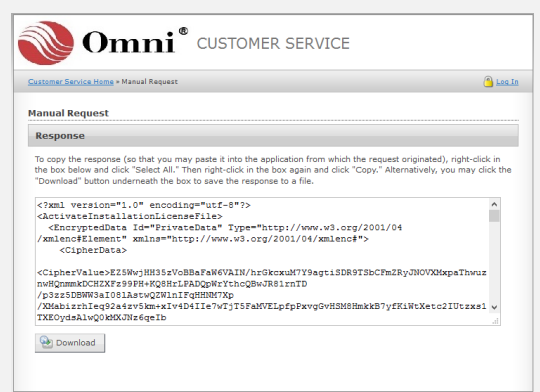

9. Transfer the activation code to the **Manual Activation** screen:

- Click **Paste** or **Load From File** if you downloaded a file.
- Click **Next**.

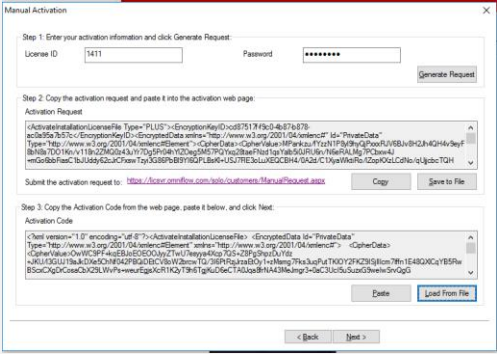

10. When the final screen appears with the OMNICONNECT license activation summary, click **Finish** to complete.

This screen confirms a successful OMNICONNECT activation.

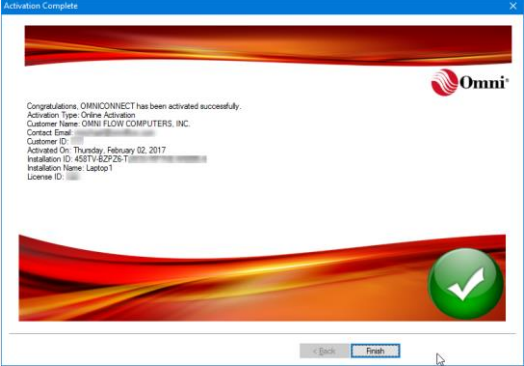

4.5.4 Phone Activation

Follow these instructions for phone activation:





The phone Activation process requires information from the welcome email:

- Registered Company Name
- Registered Contact Email
- License ID (Required during the phone call)
- Customer Password (Required during the phone call)

- 1.** Launch OMNICONNECT 7000.

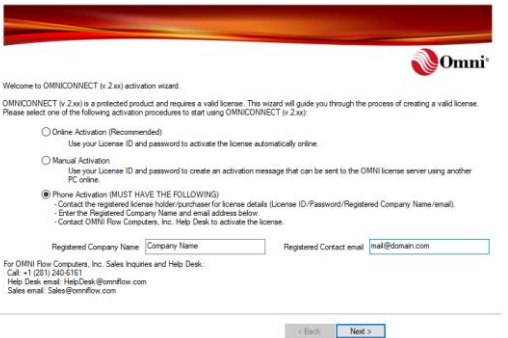
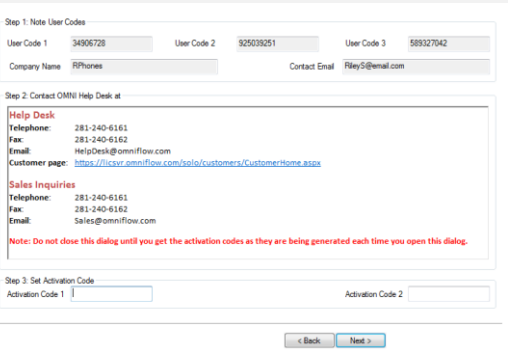
This brings up the OMNICONNECT License Activation Wizard Start Page.
- 2.** Select **Phone Activation**, click **Next**.

<p>3.</p>	<p>Fill in the Registered Company Name field and Registered Contact Email (go to the Welcome email, Section 4.5.1).</p>	
<p>4.</p>	<p>Click Next.</p> <div style="border: 1px solid blue; border-radius: 15px; padding: 10px; margin: 10px 0;"> <p>Do not close the Phone Activation page until the whole activation procedure is completed.</p> </div>	
<p>5.</p>	<p>Call OMNI Help Desk at +1 281-240-6161 and provide the three User Codes.</p> <div style="border: 1px solid blue; border-radius: 15px; padding: 10px; margin: 10px 0;"> <p>The three User Codes will be modified each time you open the phone activation dialog.</p> </div>	
<p>6.</p>	<p>OMNI Help Desk will reply back with two Activation Codes.</p> <p>Enter these codes into the Activation Code 1 and Activation Code 2 fields.</p>	
<p>7.</p>	<p>Click Next.</p> <p>The final screen in the license activation shows a summary of the license activation. Click Finish, and start using OMNICONNECT 7000.</p>	

4.5.5 30-Day and 60-Day Trial

Activate the 30-day and 60-day trial using one of the three activation methods:

- Online (Section 4.5.2)
- Manually (Section 4.5.3)
- By phone (Section 4.5.4)

Trial licenses begin on the date that the product is activated, rather than the date of purchase. Trials last for 30 or 60 days, or until a new license is installed.

For ease, the confirmation page provides the license expiration date:

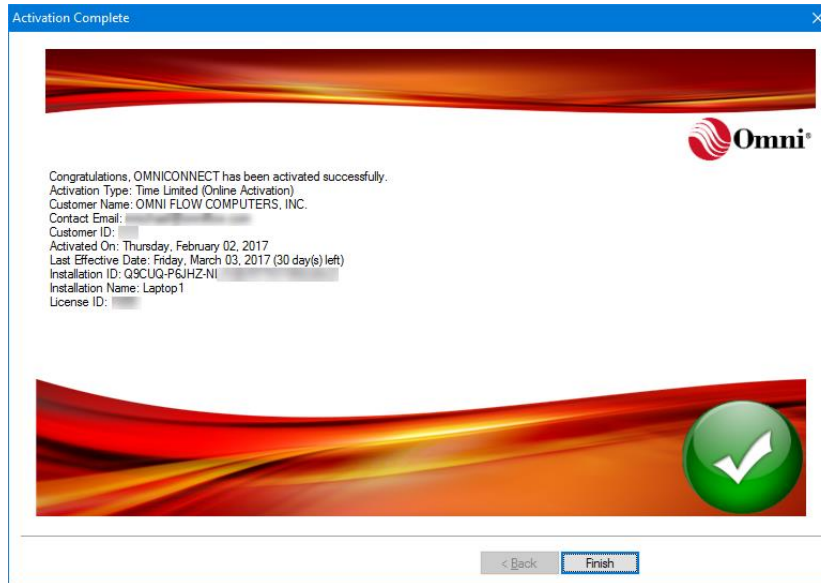

Each time you open OMNICONNECT, a reminder page will appear:

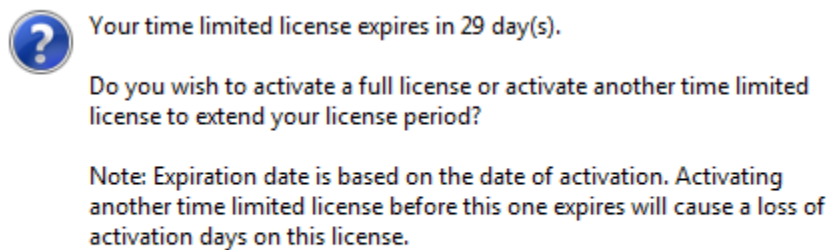

If you have purchased another trial or standard license, clicking 'Yes' will take you to the activation wizard. Clicking 'no' will allow you to continue to OMNICONNECT.

4.6 Firmware License Activation

This section describes how to activate a firmware license, which is only necessary when upgrading from the Basic license to a Standard license.



Newly-shipped standard OMNI flow computers come with the license activated. You don't need to go through this process for a new standard flow computer.

4.6.1 Welcome Email

When you purchase an upgrade to a standard CPU firmware license, you will receive a welcome email with the following information:

1. License ID
- Password
- Registered company name
- Registered contact email
- Enabled CPU Features
- Registered CPU ID(s)
- Activation Code(s)

Keep this information readily available to use during the activation process, and store it for future use.

OMNICONNECT offers three different methods of activating the firmware license: Online, Manual, and Code activation.

You can find the details of your license through the front panel by going to **Utilities**, then **Licensing**.

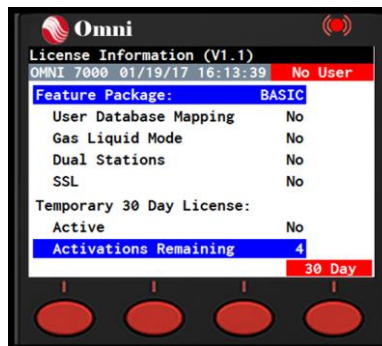



4.6.2 Online Activation



If you downloaded the firmware license before, go to 4.6.5 Update the CPU

Follow these instructions for online activation using a PC that is:

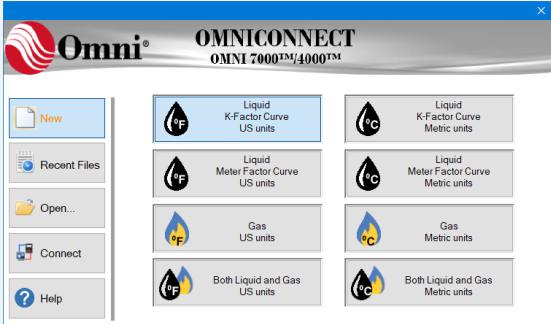
- Hosting an activated OMNICONNECT
- Connected to the flow computer
- Connected to the internet

<p>1. Launch OMNICONNECT 7000.</p>	
<p>2. a. Click on Connect to connect to the target flow computer. b. Login to the target unit.</p>	
<p>3. On the ribbon bar, click License.</p>	
<p>4. Click Manage CPU Features.</p>	

5. Click **Add License**.

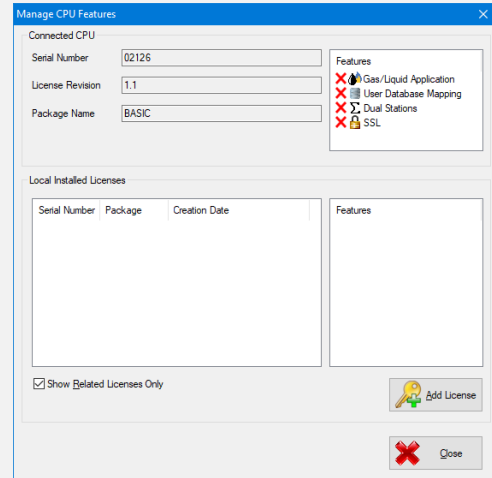

6. Select **Online Activation**.

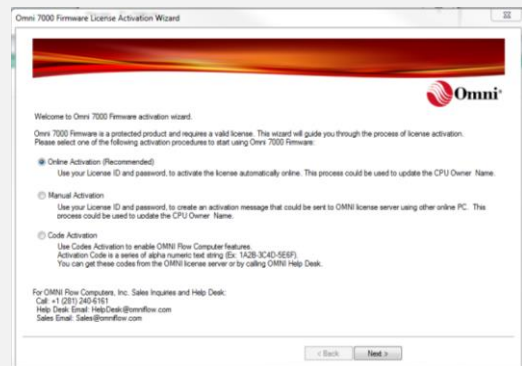

7. Click **Next**.

8. Enter the **License ID** and **Password** (from the Welcome email, Section 4.6.1).
If you are using a proxy server, proceed to Step 9.
Otherwise, click **Next**.

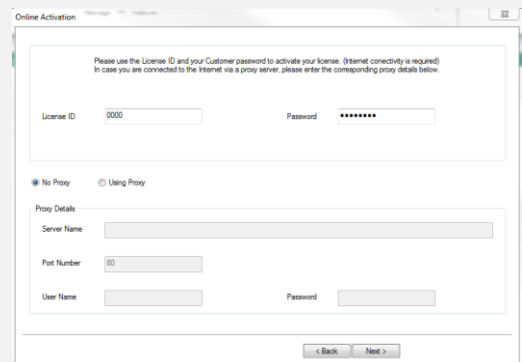

9. If using a proxy server, select **Using Proxy** and enter the corresponding proxy details.
When you are finished, click **Next**.

Contact your network administrator for proxy information.

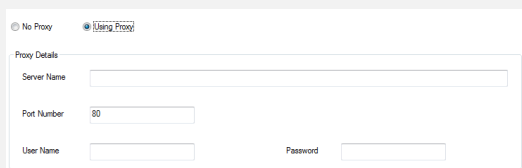

10. The final screen shows a summary of the Firmware license activation. Click **Finish** to complete.

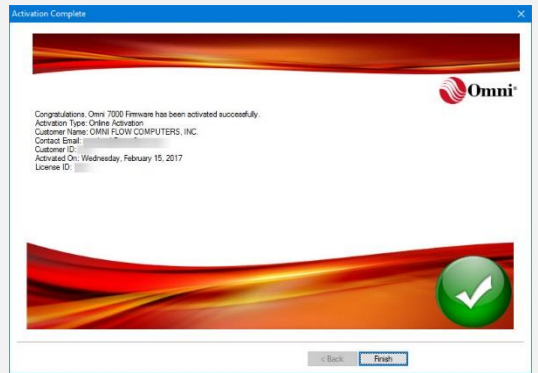

4.6.3 Manual Activation

Use manual activation for a PC that will be connected to a flow computer(s) but will not have an internet connection (offline). Follow these instructions for manual activation.

1. Launch OMNICONNECT 7000.

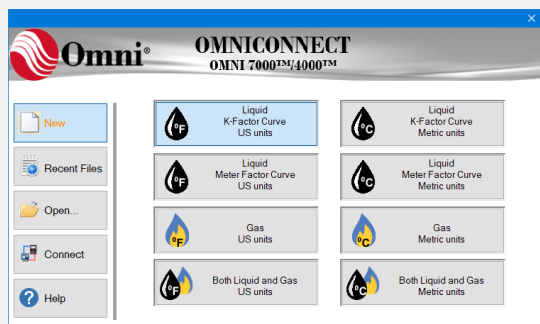

2.
 - a. Select the target flow computer and click **Connect**.
 - b. Login to OMNICONNECT.

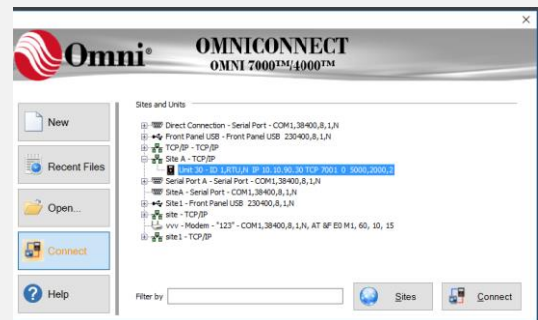

3. On the ribbon bar:
 - a. Click **License**.
 - b. Click **Manage CPU Features**.

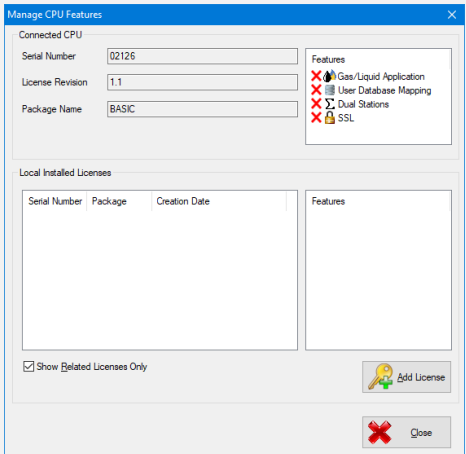
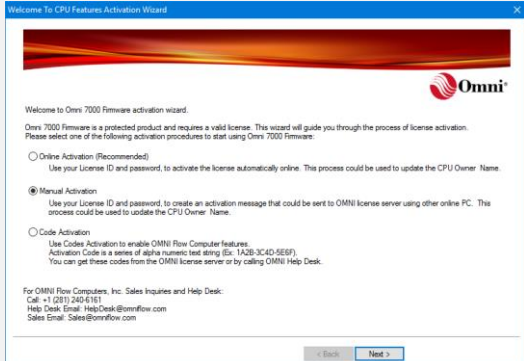
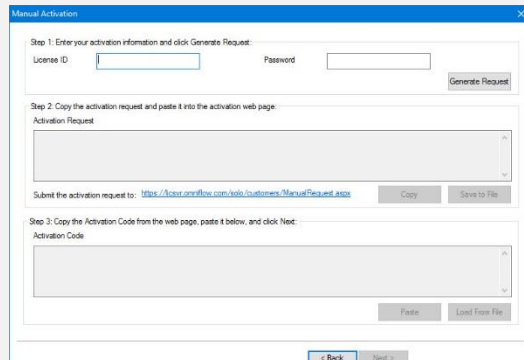
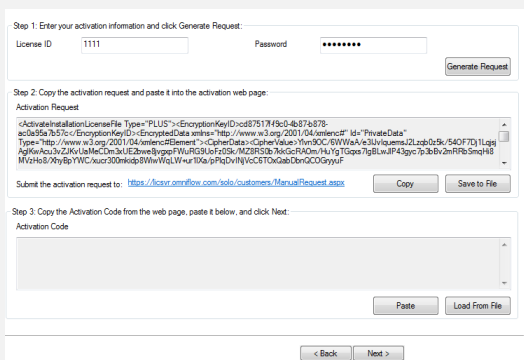

<p>4.</p>	<p>Click Add License.</p>	
<p>5.</p>	<p>Select Manual Activation. Click Next.</p>	
<p>6.</p>	<p>In the Manual Activation screen, Step 1, enter the License ID and Password (from the Welcome email, Section 4.6.1).</p>	
<p>7.</p>	<p>Click Generate Request.</p> <p>This will generate a message in Step 2 in the Activation Request box.</p> <div style="border: 2px solid blue; border-radius: 15px; padding: 10px; margin-top: 10px;"> <p>Do not close this dialog or navigate back during the activation process. A submitted activation request must match the retrieved activation code.</p> </div>	

- 8.** Click **Copy** to copy the activation request or click **Save to File** to save the request as a file.

Transfer the activation request and the OMNI URL <https://licsvr.omniflow.com/solo/customers/ManualRequest.aspx> to an online PC.

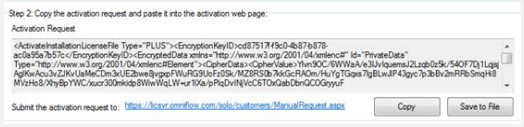

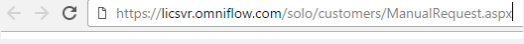
- 9.** At the online PC, open an internet browser and navigate to the URL to access the OMNI license server (OLS).

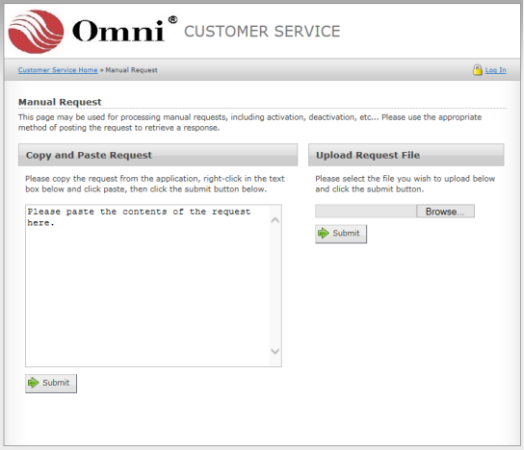

- 10.** At the **Manual Request** screen on the OMNI customer service site, follow the instructions under **Copy and Paste Request** or **Upload Request File** if you saved a file.

- 11.** In the next screen, **Response**, follow the instructions on the page.

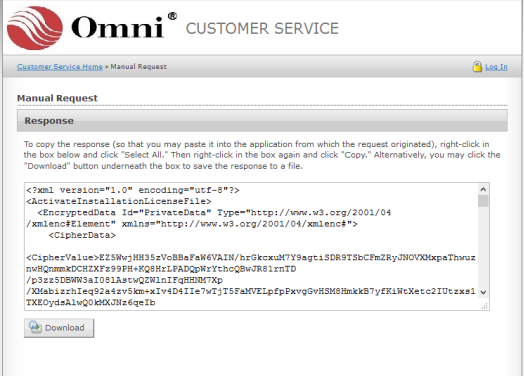
Depending on your browser, you may need to highlight a line of text before selecting all and copying.

If you uploaded a file, follow the alternative download instructions.

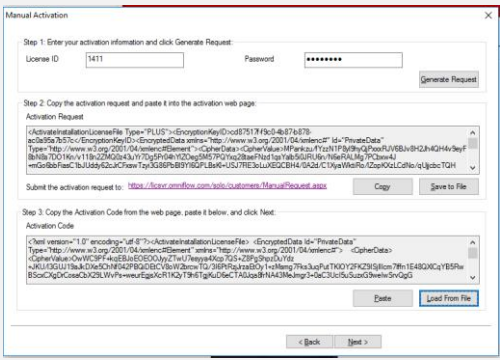
- 12.** Transfer the activation code to the offline PC on the in the **Manual Activation** screen:

 - a. Click **Paste** or **Load From File** if you downloaded a file.
 - b. Click **Next**.

13. When the final screen appears with the Firmware license activation summary, click **Finish** to complete.

This screen confirms a successful Firmware activation.

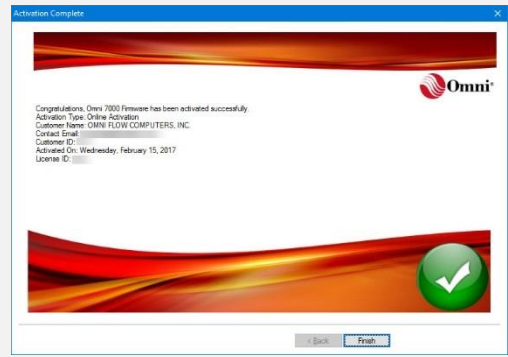

4.6.4 Code Activation

When there is no internet connection, follow these instructions to complete code activation.

1. Launch OMNICONNECT 7000.

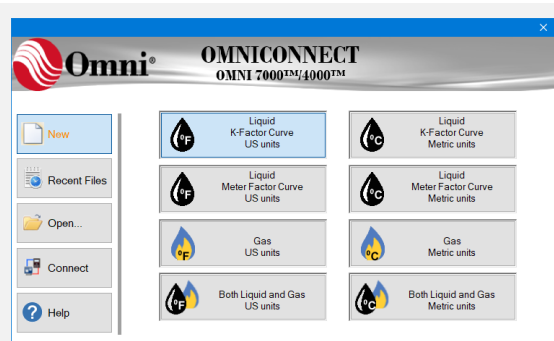

2. Click on **Connect** to connect to the target flow computer.

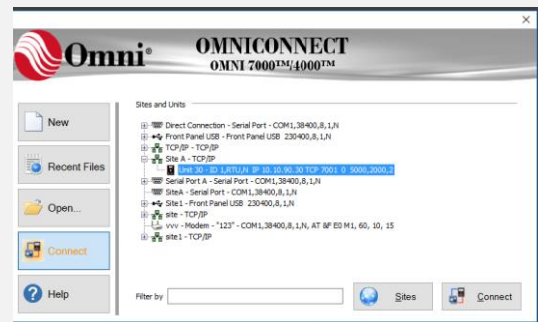

3.
 - a. On the ribbon bar, click **License**.
 - b. Login to OMNICONNECT.



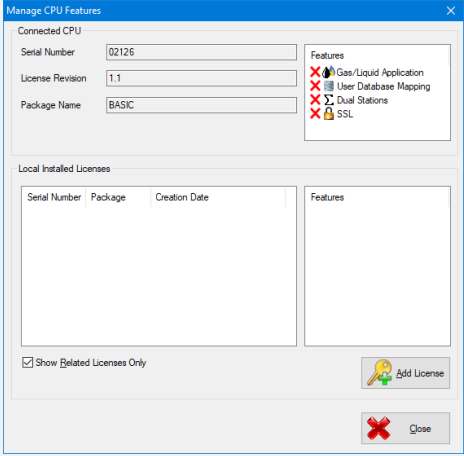
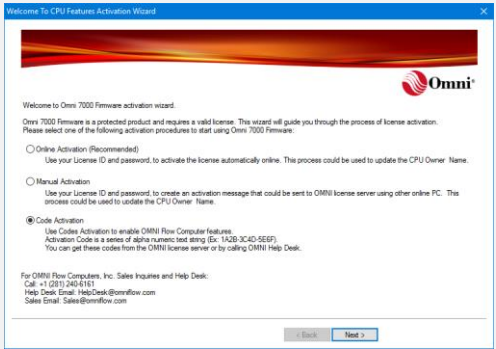
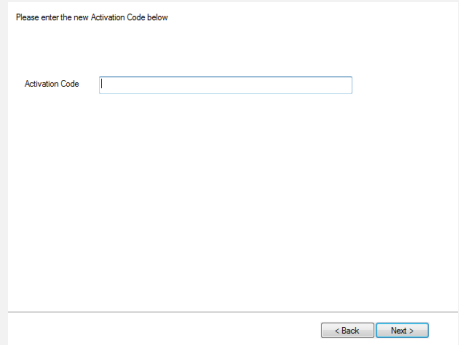
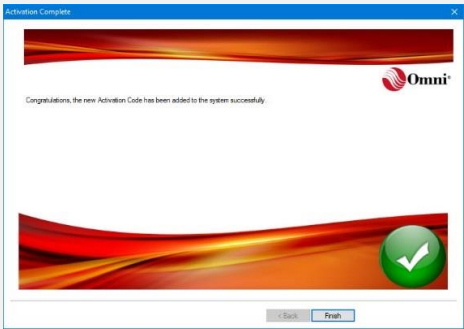

4. Click **Manage CPU Features**.

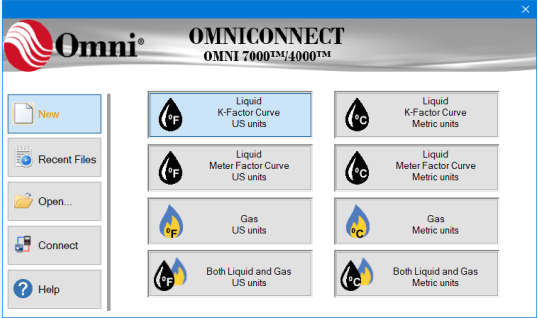

<p>5.</p>	<p>Click the Add License button.</p>	
<p>6.</p>	<p>a. Select Code Activation. b. Click Next.</p>	
<p>7.</p>	<p>a. Enter the required Activation Code(s).</p> <div data-bbox="381 1071 868 1239" style="border: 2px solid blue; border-radius: 15px; padding: 10px; margin: 10px 0;"> <p>These are in the Welcome email. Contact your system administrator if you don't have the email.</p> </div> <p>b. Click Next.</p>	
<p>8.</p>	<p>Click Finish to complete.</p>	

4.6.5 Update the CPU

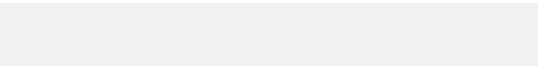
To update the CPU, follow these instructions:

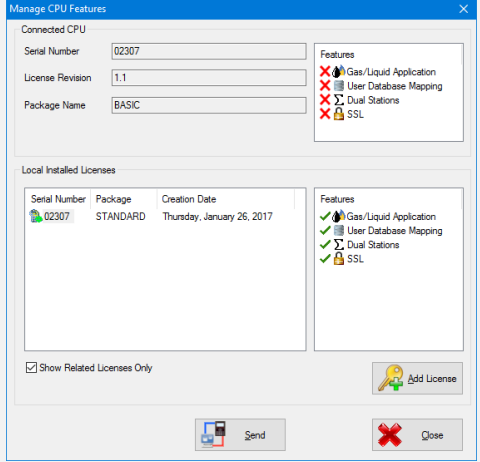
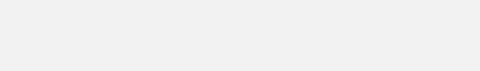
<p>1.</p>	<p>Launch OMNICONNECT.</p>	
<p>2.</p>	<p>Click on Connect to connect to the target flow computer.</p>	
<p>3.</p>	<p>On the ribbon bar, click License.</p>	
<p>4.</p>	<p>Click Manage CPU Features.</p>	
<p>5.</p>	<p>Select the required license.</p>	
<p>6.</p>	<p>Click the Send button to update the connected CPU.</p>	

4.7 Configure OMNICONNECT™ Connection

When configuring the OMNICONNECT connection on your PC, follow the instructions in this section in conjunction with OMNICONNECT Help.



At any point, you may press F1 on your keyboard to access OMNICONNECT Help for more detailed descriptions of each window, screen and field. Your cursor must be on the window, screen or field.

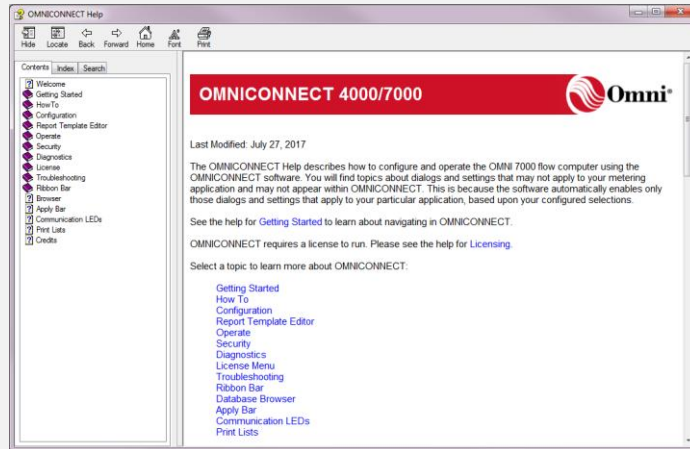

4.7.1 Startup Screen

When OMNICONNECT opens, you must choose the required type of application (Figure 4-3). For more information about the different application choices presented on this screen, open OMNICONNECT Help by clicking on the Help button in the lower left-hand corner of the window.

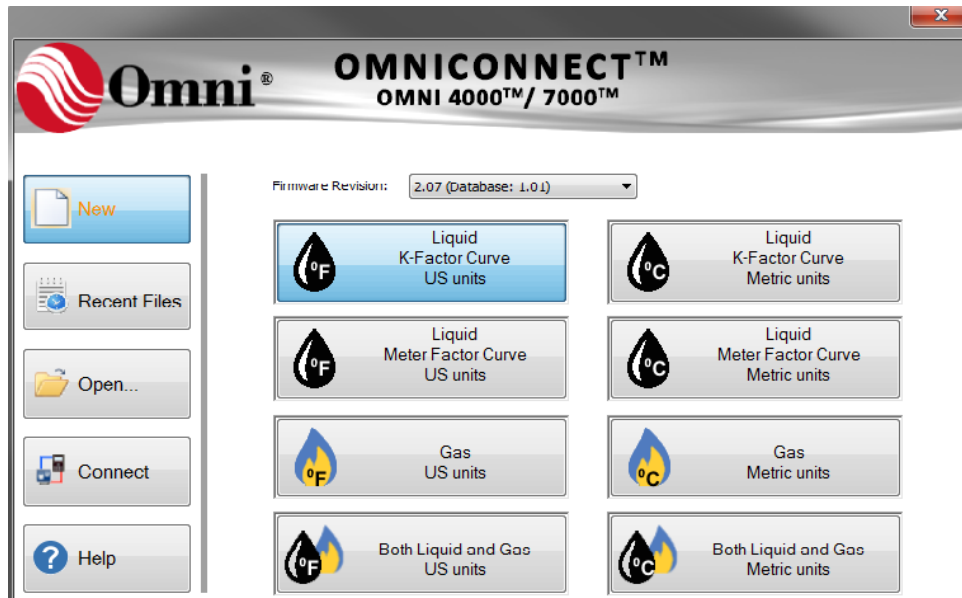

Figure 4-3: Startup Screen

The different types of applications (liquid, gas, liquid and gas) share the basic general setup configurations, with some variation. Choose the type of application based on the parameters of your flow computer.

The OMNICONNECT home page opens in the Home tab on the ribbon bar, which houses the main components of the OMNICONNECT system for initial configuration and later operations (Figure 4-4).

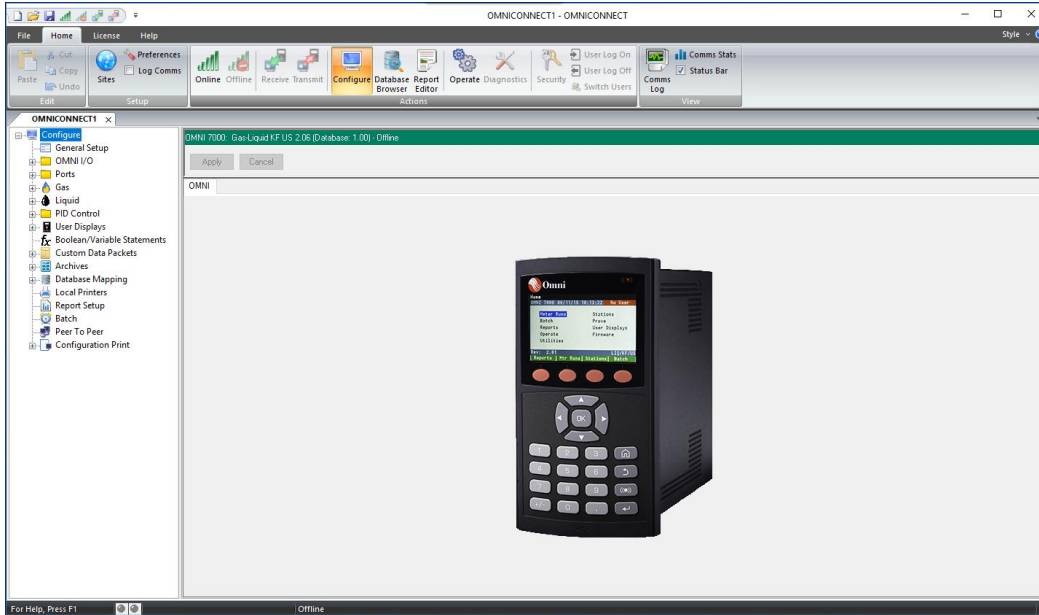

Figure 4-4: OMNICONNECT Home Page

Home

The three main components of the Home ribbon (Figure 4-5) are Setup, Actions and View (Table 4-3).



Figure 4-5: OMNICONNECT Icons

Table 4-3: Home Ribbon Elements and Descriptions

Home Ribbon Elements	
Setup Box	Descriptions
1 Sites	Opens the Sites Setup window and is used to configure the connection sites for communicating with the units.
Preferences	Opens the Preferences window and is used to set the location in your PC where OMNICONNECT will save the reports, archives and other configurations that are set within the software.
Log Comms	Enables the logging of the Modbus communications between the OMNICONNECT user interface and the flow computer screens.

Home Ribbon Elements		
Actions Box	Descriptions	
2	Online/Offline	Online connects OMNICONNECT to the flow computer through Direct, Modem, Satellite, TCP/IP or USB communication modes. Offline allows the user to disconnect the flow computer from OMNICONNECT to work with files.
	Receive/Transmit	Receive reads the entire configuration from the OMNI flow computer, with the option to exclude custom report templates. Transmit sends the entire configuration to the flow computer, with the option to exclude custom report templates.
	Configure	Opens the Configure tree in the left panel to allow for the configuration of the flow computer for operation.
	Database Browser	Opens the OMNI Modbus Database Browser window.
	Report Editor	Allows the user to modify or create custom report templates for the purpose of creating custom reports.
	Operate	Performs operations, such as retrieving reports, archiving data, prover control and batch operations.
	Diagnostics	Provides access to I/O Overview, Calibration, System Information and Flashing Utility when connected through the CPU USB port and a Modbus communications test utility.
	Security	Provides the Administrator access to set up the user accounts and passwords.
	User Log On/Off	Allows the Administrator or User to log on or off the flow computer.
	Switch Users	Allows the Administrator or User to switch between users.
View Box	Descriptions	
3	Comms Log	Opens the Communications Log window, which shows the record of the Modbus communications between the user interface and the flow computer, if enabled.
	Comms Stats	Opens the Communications Statistics window, which shows the statistics accumulated during Modbus communications.
	Status Bar	Displays or hides the Status Bar at the bottom of the OMNICONNECT screen.

File

The File ribbon holds the New, Open and Save functions.

License

The License ribbon holds the options for updating, deactivating, reviewing, and retrieving your OMNICONNECT and CPU Firmware licenses and features.



Help

The Help ribbon houses functions to view the software release notes, check for updates to the OMNICONNECT software, check for updates to the firmware and connect to the OMNICONNECT Help topics.

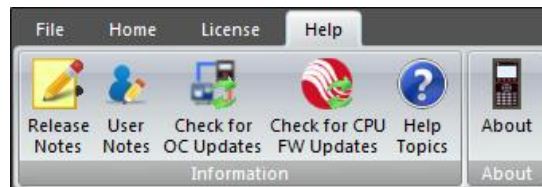

The About box shows information about the program's revision, release date and licensing.

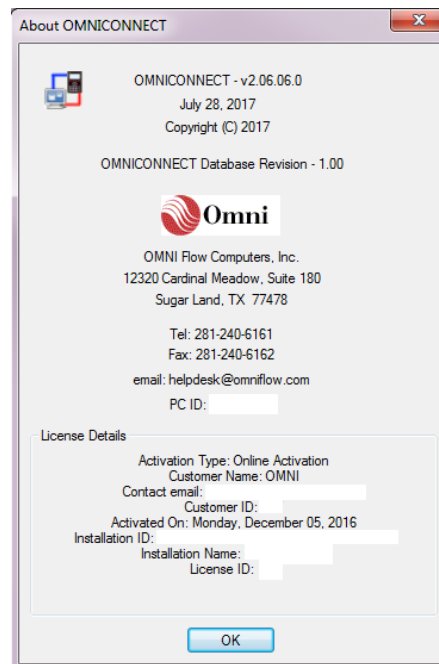

Apply Bar and Title Bar

The upper title bar on the Apply bar shows the name, application type, CPU number and site name of the flow computer. When the flow computer is online, the title bar is red.

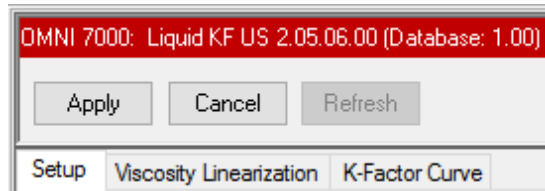

When the flow computer is offline, the title bar is green (Figure 4-4).

If any changes are made to any display screen in OMNICONNECT, the **Apply** button will activate in the **Apply** bar above the screen. Click **Apply** to save any selections or any edits made to fields before moving to the next screen. The **Cancel** button cancels any edits, and the **Refresh** button reads information on the page from the flow computer.

4.7.2 Setup Sites

After the OMNICONNECT software is activated, connect the software on your PC to the flow computer through a selected communication method. Follow the instructions in this section to configure sites and units within OMNICONNECT to allow access to the flow computers.



If you have previously configured serial or Ethernet ports through the flow computer's front panel (Section 4.3.1 and 4.3.2), you still must create sites to match them in OMNICONNECT to communicate with those ports, as they are not created automatically.

Connecting through a Serial Port

To connect through a Serial port, follow these instructions:

1. Click the **Home** tab on the OMNICONNECT ribbon.
2. Click the **Sites** button in the Home ribbon to open the **Setup Sites** window.



Unless it was previously deleted, the default serial port site is already listed.

3. In the **Setup Sites** window, click **Add Site** to open the **Setup Communications** window.

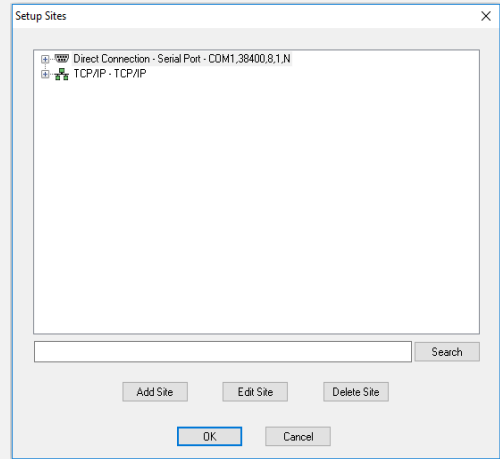

4. a. In the **Setup Communications** window, select **Serial Port** from the **Media Type** drop-down list.
 b. In the **Site Name** field, enter a name for this site.
 c. Select the the serial port number on your PC from the **Comm Port** drop-down list. This number is not the flow computer serial port number.
 d. Adjust all the other parameters to match the values specified when the serial port was configured from the front panel of the flow computer.

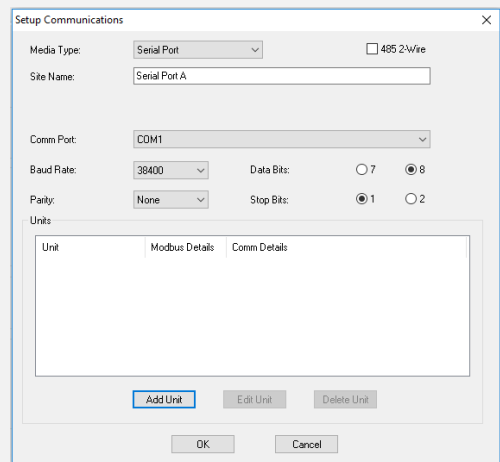

5. Click **Add Unit** to open the **Setup Unit** window.

6. In the **Setup Unit** window, enter a name for your flow computer in the **Unit Name** field.

Make sure that the other parameters match the serial port settings in the flow computer (go to Section 4.3.1 if needed).

Click **OK** to save the changes.

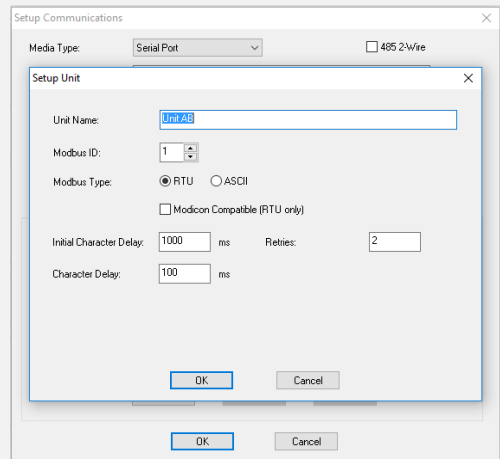

7. Repeat Steps 5 and 6 to add more units to this serial port site, as needed.

8. When you have finished adding units, click **OK** to exit the remaining open windows, **Setup Unit** and then **Setup Communications**.
9. You can repeat the previous steps to add more serial port sites and units.

Connecting through an Ethernet Port

To connect through an Ethernet port, follow these instructions:

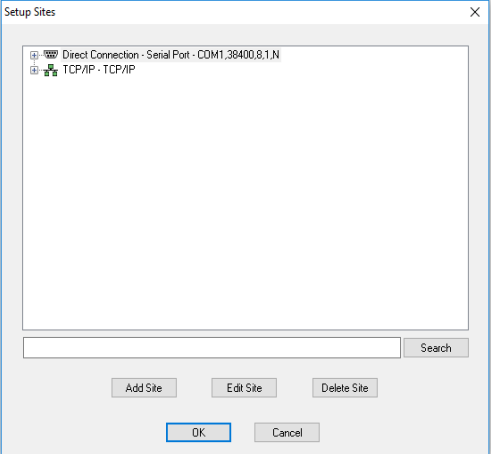
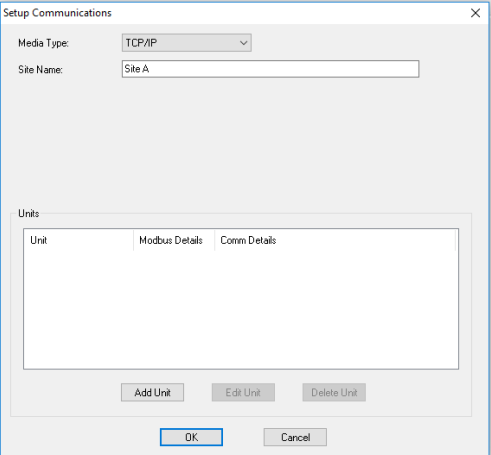
1. Click the **Home** tab on the OMNICONNECT ribbon.
2. Click the **Sites** button in the Home ribbon to open the **Setup Sites** window.
 
3. In the **Setup Sites** window, click **Add Site** to open the **Setup Communications** window.
 
4.
 - a. In the **Setup Communications** window, select **TCP/IP** from the **Media Type** drop-down list.
 - b. In the **Site Name** field, enter a name for this site
5. Click **Add Unit** to open the **Setup Unit** window.

6.
 - a. In the **Setup Unit** window, enter a name for the flow computer in the **Unit Name** field.
 - b. In the **IP Address** field, enter the IP address assigned to your flow computer (Section 4.3.2).
 - c. Adjust the Modbus ID, Modbus Type, Modicon Compatible, and Modbus Port settings to exactly match the settings specified when the Ethernet port was configured from the front panel of the flow computer.

Click **OK** to save the changes.

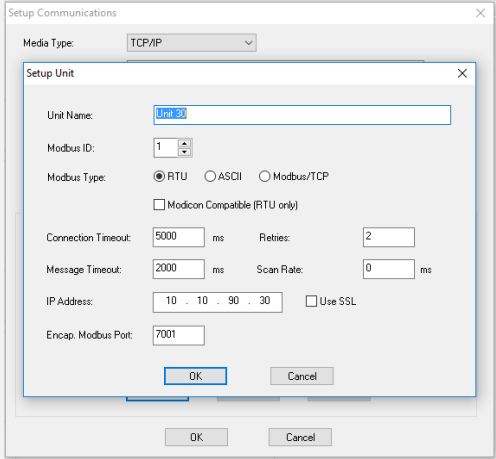

7. Repeat Steps 5 through 6 to add more units to this Ethernet site, as needed.
8. When you have finished adding units, click **OK** to exit the remaining open windows (**Setup Unit** and **Setup Communications**).
9. You can repeat the previous steps to add more Ethernet sites and units.

Connecting through a USB Port

To connect through the front panel USB port or OMNI CPU USB port, follow these instructions:

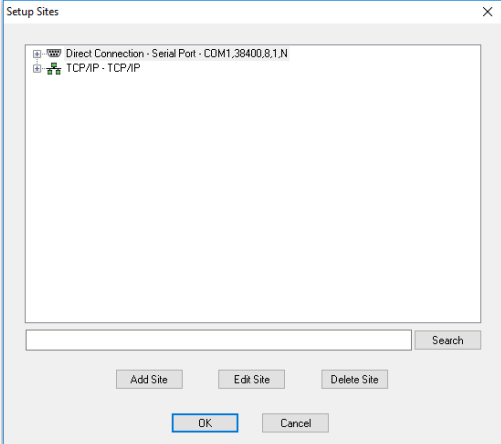
1. Click the **Home** tab on the OMNICONNECT ribbon.
2. Click the **Sites** button in the Home ribbon to open the **Setup Sites** window.
 
3. In the **Setup Sites** window, click **Add Site** to open the **Setup Communications** window.
 

4.
 - a. In the **Setup Communications** window, select **Front Panel USB** (or **OMNI CPU USB**) from the **Media Type** drop-down list.
 - b. In the **Site Name** field, enter a name for this site.

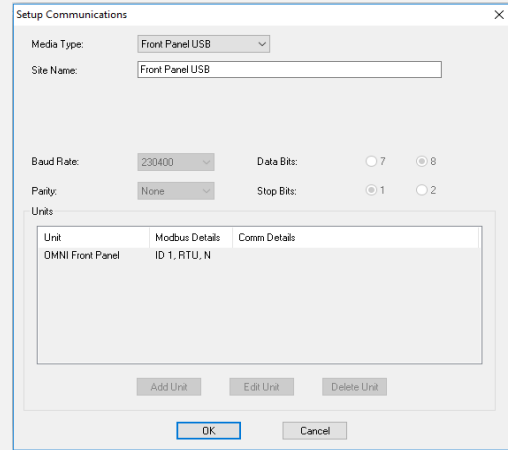

When a USB site is selected, a single OMNI CPU or front panel unit is automatically added, and its default settings cannot be changed.

5. Click **OK** to exit the **Setup Communications** window.

Connecting through a Modem or Satellite

To connect through a Modem or Satellite, follow these instructions:

1. Click the **Home** tab on the OMNICONNECT ribbon.
2. Click the **Sites** button in the Home ribbon to open the **Setup Sites** window.
3. In the **Setup Sites** window, click **Add Site** to open the **Setup Communications** window.

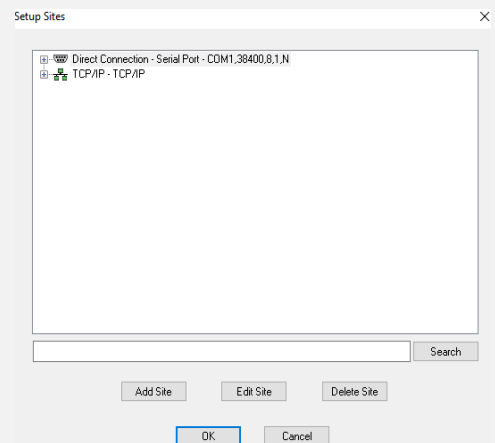

4.
 - a. In the **Setup Communications** window, select **Modem or Satellite** from the **Media Type** drop-down list.
 - b. In the **Site Name** field, enter a name for this site and select the appropriate communications parameters.
 - c. In the **Phone Number** (for modem sites) or **Satellite Number** (for satellite sites) field, enter the appropriate number, as required.
 - d. Adjust all the other parameters to match the values specified when the communication port was configured from the front panel of the flow computer.

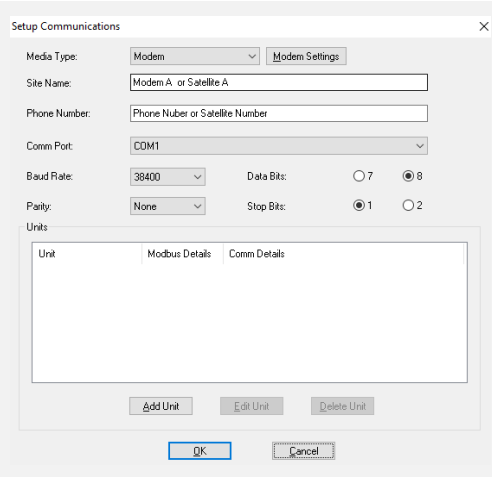

5. For both Modem and Satellite, click **Modem Settings** and edit the settings as appropriate.
- Click **OK** to save the changes.

Refer to the modem or connection device manual for the correct Initialization String.

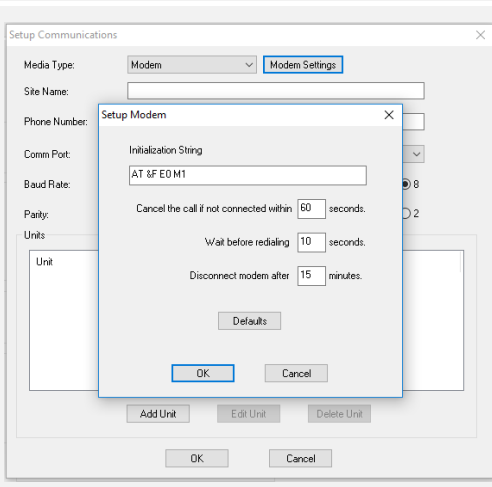

6. If needed, click **Add Unit** to open the **Setup Unit** window.
- In the **Setup Unit** window, enter a name for the flow computer in the **Unit Name** field.
- Click **OK** to save the changes.

The Initial Character Delay and Character Delay timeout settings may need to be increased if communicating remotely through a slow satellite link.

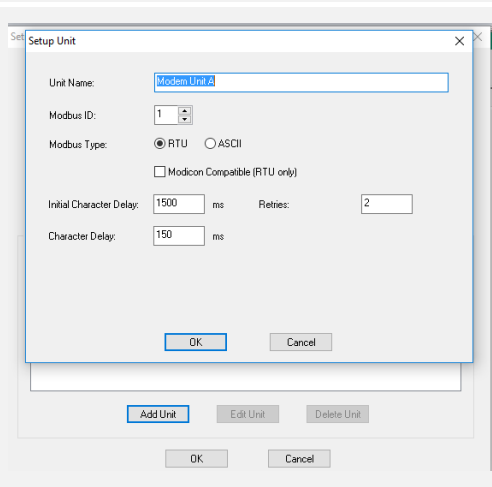

7. Repeat Step 6 to add more units to this modem or satellite site, as needed.

8. When you have finished adding units, click **OK** to exit the remaining open windows, **Setup Unit** and then **Setup Communications**.
9. You can repeat the previous steps to add more modem or satellite sites and associated units.

4.7.3 Setup Preferences

Follow these instructions to change the default preferences.

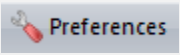
1. Click the **Home** tab on the OMNICONNECT ribbon.
2. Click the **Preferences** button in the Home ribbon to open the **Setup Preferences** window.
 
3. In the **Setup Preferences** window, change the preferences as needed.

Press F1 to access OMNICONNECT Help for assistance.

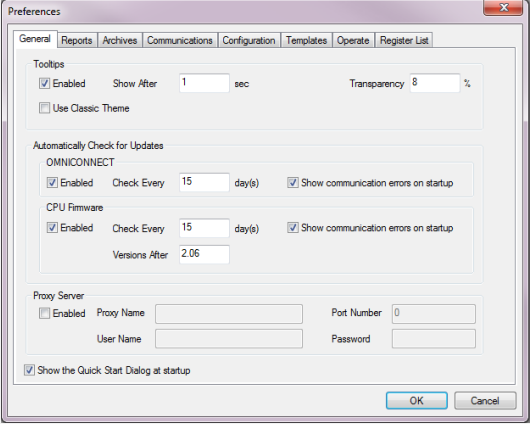



On the first **General** tab, the **Automatically Check for Updates** box is enabled by default for both the OMNICONNECT software and the CPU firmware. The number you enter in the **Versions After** box will limit the search to only include the releases after that version. Go to Section 4.9 for more information on checking for updates.

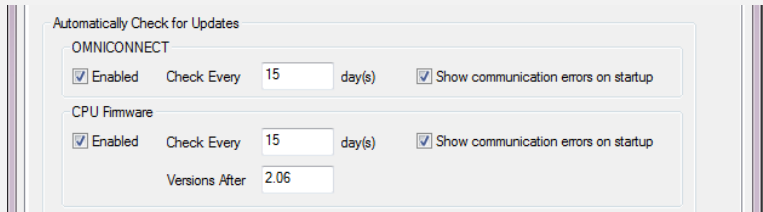

4. If you are connected to a proxy server, you must select the **Enabled** checkbox and complete the fields.

Contact the network administrator for proxy information.

5. Click **OK** when you have changed preferences.

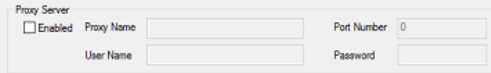

The image shows a 'Proxy Server' configuration window. It contains an 'Enabled' checkbox, a 'Proxy Name' text field, a 'Port Number' text field with '0' entered, a 'User Name' text field, and a 'Password' text field.

4.7.4 Connect to the Flow Computer

To connect the OMNICONNECT software to the flow computer, follow these instructions:

1. Click the **Online** button in the Home ribbon to see the **Connect to OMNI** window.



The image shows a button with a green bar chart icon and the word 'Online' below it.

2. In the **Connect to OMNI** window, choose which unit to connect with from the list presented.

These are the sites and units you previously created in Section 4.7.2 Setup Sites .

Double click or click to highlight and click **Connect**.

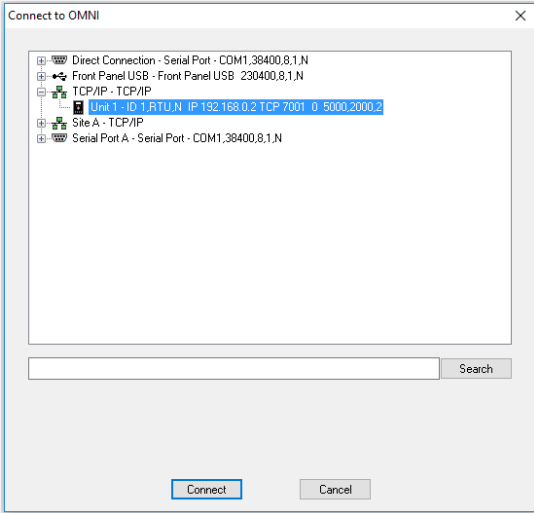

The image shows the 'Connect to OMNI' window. It has a tree view with the following items: 'Direct Connection - Serial Port - COM1,38400,8,1,N', 'Front Panel USB - Front Panel USB 230400,8,1,N', 'TCP/IP - TCP/IP', 'Unit 1 - ID 1,RTU,N IP:192.168.0.2,TCP 7001_0_5000,2000,2', 'Site A - TCP/IP', and 'Serial Port A - Serial Port - COM1,38400,8,1,N'. The 'Unit 1' item is highlighted. Below the tree is a search bar and 'Connect' and 'Cancel' buttons.

3. In the **Password** window, select the Administrator user from the drop-down list, or **User 00**. The default factory password is **omni** in lowercase letters.

Click **OK**.

If you already changed your password and set up users, then enter your own password.

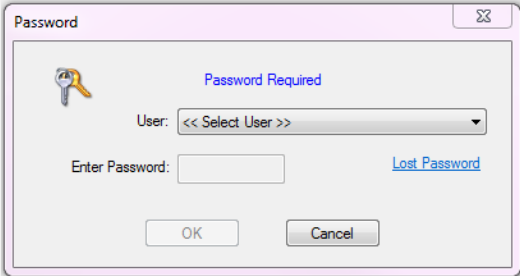

The image shows the 'Password' window. It has a key icon, a 'Password Required' label, a 'User:' dropdown menu with '<< Select User >>' selected, an 'Enter Password:' text field, a 'Lost Password' link, and 'OK' and 'Cancel' buttons.

4. You are now connected to the flow computer (online), but you are not yet receiving data.



Click the **Receive** button in the Home ribbon to open the **Receive Data from OMNI Unit** window and receive the default configuration from the flow computer.



The **Receive Data from OMNI Unit** window will present a message that contains firmware license information, which lists the features that are licensed in the firmware of this particular OMNI flow computer and the features that are not licensed.

5. Click **Start** to receive the data from the unit and continue initial configuration.

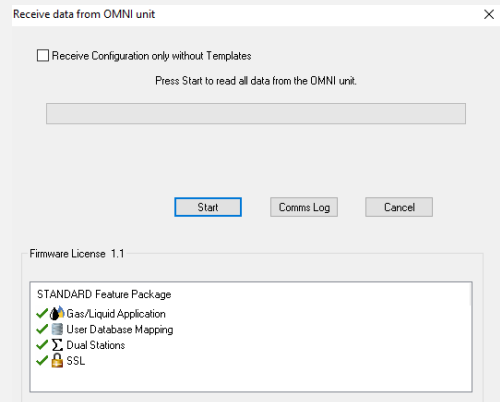

6. If you are trying to connect to a unit through an Ethernet site and an error message pops up, click **OK** on the message and click **Cancel** on the **Connect to OMNI** window.

Continue to Step 7.

An error message may mean that your OMNICONNECT Site file settings do not match the configured port settings on the Omni 4000/7000.

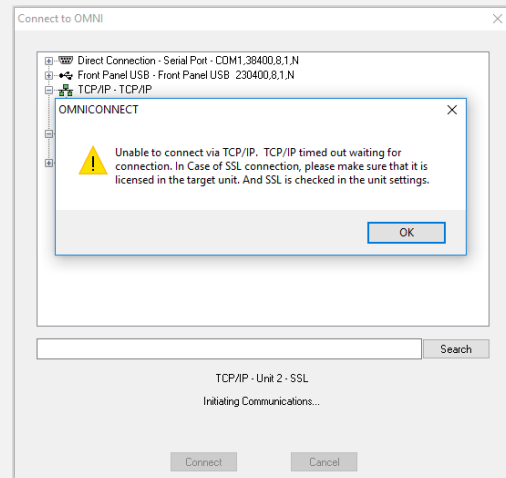

7. Open the **Setup Sites** configuration window again, select the unit that returned the error message, and click **Edit Unit**.

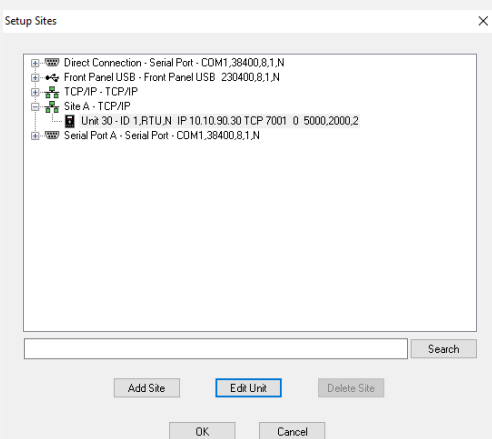

8.

- Review the information in the **Setup Unit** window.
- With this window open, navigate to the settings of a unit at this site through the front panel of the flow computer (Go to Section 4.3 Configuring Communication Ports (Front Panel)).
- Check to see whether the information matches.
- Make corrections to the settings, as needed, to confirm that they match.

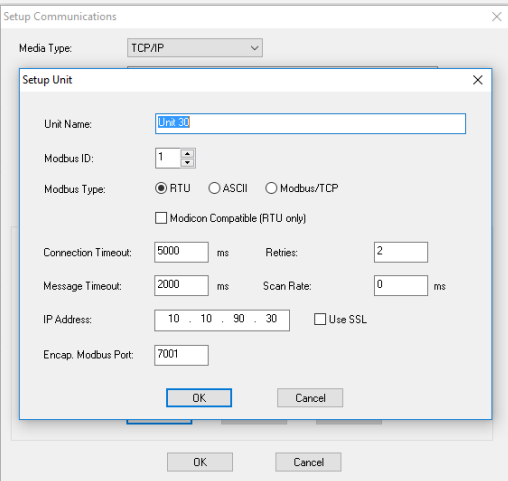

9. Click **OK** twice to close both **Setup Sites** windows and save your changes when you have confirmed that the settings match.

Return to Step 1 to try to connect to the flow computer again.



4.8 Security Setup

Setting up additional user profiles or editing any part of the original Administrator login information provided by OMNI is optional.

However, if multiple users make changes to any settings of the flow computer by using the Administrator login, those changes cannot be tracked to an individual user.

User security controls the available user functionality for the front panel, OMNICONNECT and OMNIPANEL. Port security controls the security configuration for devices such as SCADA or human machine interface (HMI) systems.

4.8.1 Administrator Functions

OMNICONNECT permits one Administrator and up to 16 user profiles to be established in the system. The Administrator's permission is not customizable, and it is set for full access. The system Administrator can customize the permissions for each individual user and port, which can include:

- Viewing, configuring or resetting the security of all users.
- Giving users the ability to change their own passwords (the default is **no**).
- Changing the length of the timeout for the OMNICONNECT and OMNIPANEL user password, ranging from zero (no time out) to 1,440 minutes (24 hours).

4.8.2 User Security

To create each individual user profile while you are logged in as the Administrator, follow these instructions:

- Click the **Security** button in the Home ribbon to open the **Security** tree in the left panel.

You must be connected to a flow computer to use user security.

- Select **Administrator** in the **Security** tree. In the **User Information** tab, change your User ID and Password from the default Administrator and Password.

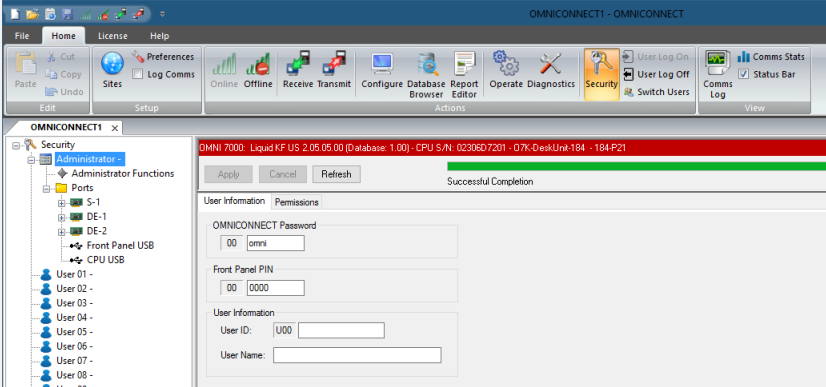

3. Fill in the **User Information** fields for your profile. Enter both the OMNICONNECT password and the front panel PIN twice to confirm them.

The screenshot shows a configuration form with two tabs: "User Information" (selected) and "Permissions". The form contains three main sections:

- OMNICONNECT/OMNIPANEL Password:** Two input fields, one with "00" and a "Confirm:" field. A callout bubble indicates: "Maximum 6 characters alphanumeric".
- Front Panel PIN:** Two input fields, one with "00" and a "Confirm:" field. A callout bubble indicates: "4 to 6 numerical digits".
- User Information:** A "User ID:" field with "U00 Admin" and a "User Name:" field. A callout bubble indicates: "Maximum 12 alphanumeric characters for use in the audit trails". Another callout bubble at the bottom indicates: "Maximum 32 alphanumeric characters".

4. Select a user profile to edit.

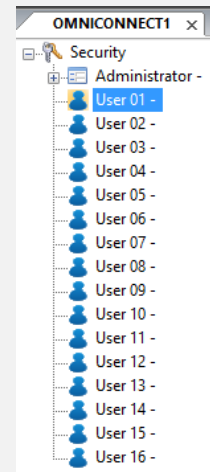

5. Fill in the **User Information** for that individual profile.

- Click the **Permissions** tab to continue to edit the user security profile by choosing specific permissions to allow the user to access, according to User Permissions guidelines.

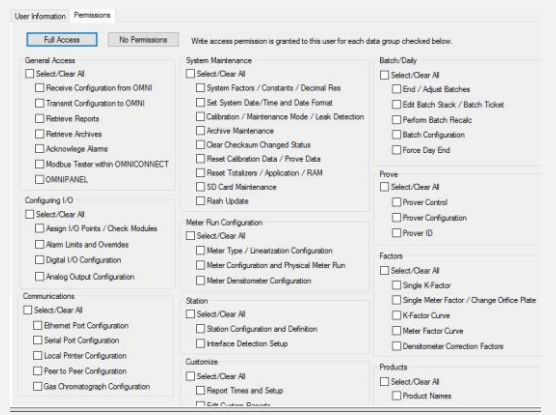

4.8.3 User Permissions Guidelines

The Administrator can view and edit the permissions for each user and port. Users can view their permissions only. The permissions can be given as a whole or individually. The Administrator can set or reset all of the permissions for a user by selecting:

- Full Access to select all permissions.
- No Permissions to clear all permissions.

The permissions are grouped according to function, and there is a Select/Clear All checkbox in each group. Within these functions, the Administrator can:

- Check the group box to select all of the items in the group.
- Uncheck the box to clear all of the items in the group.

If a user attempts to edit an item or perform a function that he or she does not have permission for, the OMNI 4000/7000 will return an Exception Code 05.



If you are unsure about which permissions to give for a specific user, hover over the item with the cursor, and a pop-up box will appear with the needed permission to select in the user's profile.

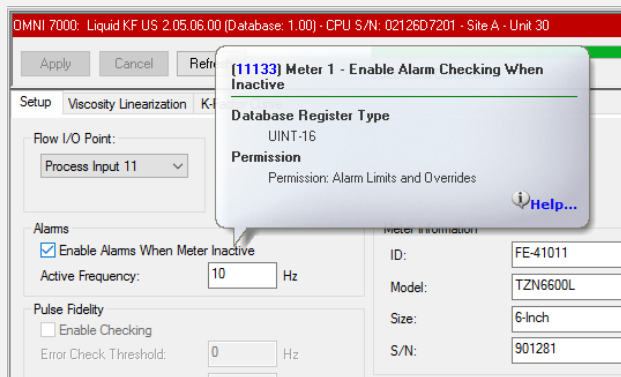

Some items within OMNICONNECT cannot be viewed when the user does not have permission. These items include:

- General Access
 - Receive Configuration from OMNI, which is disabled on the ribbon bar and when the user expands the Configuration Tree or the Report Editor Tree

- Transmit Configuration to OMNI, which is disabled on the ribbon bar and when the user expands the Configuration Tree or Report Editor Tree
- Customize
 - Edit Custom Reports, which is disabled on the ribbon bar. When the user expands the Report Template Editor Tree, the Work Online with Templates option is disabled.

4.8.4 Port Security

Similar to configuring user security, the default setting on the flow computer for port security by the firmware is disabled. The Administrator must manually enable security for ports, and only the Administrator may configure port security.



Port security is automatically bypassed for gas chromatographs, peer-to-peer master and slave serial ports.

To edit port security while logged in as the Administrator, follow these instructions:

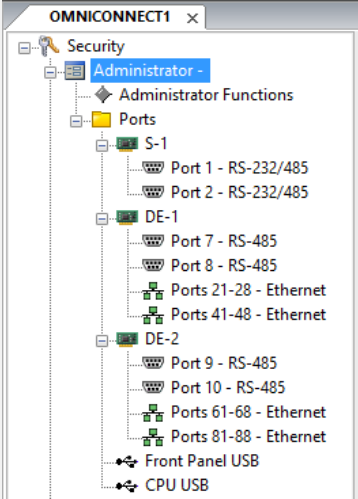
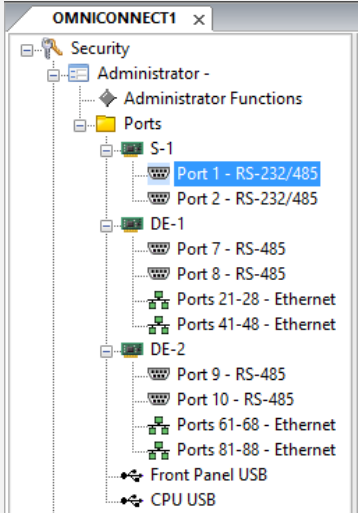
1.	Click the Security button in the Home ribbon to open the Security tree in the left panel.	
2.	In the left panel, expand the tree under Administrator and under Ports to see the list of all the ports reflected by the modules installed on the flow computer.	
3.	Select a port to configure its security settings.	

4. There are eight configurable entries for each port. Each entry contains the following:

Entry No.	Port ID	Audit ID	ASCII Password	Integer Password	Time Out (seconds)
1	P01-1			0	0
2				0	0
3				0	0
4				0	0
5				0	0
6				0	0
7				0	0
8				0	0

10 alphanumeric characters for identification and auditing purposes.

Inactivity timeout range: 0-120 seconds.

4-8 alphanumeric characters. To access the port externally, write the 8-byte ASCII password using Modbus Index 4850 with Modbus function code 06 or 16.

32-bit integer ranging from 0-9999999. To access the port externally, write the 32-bit integer password using Modbus Index 6950 with Modbus function code 06 or 16.

5. Click the **Permissions** tab for each password within each port to edit specific permissions to allow access for a specific user, according to the following section on Port Permissions Guidelines.

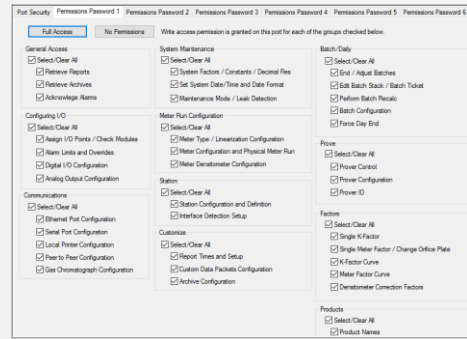

4.8.5 Port Permissions Guidelines

The Administrator can view and edit the permissions for each port. Each of the eight entries for a port has a set of port permissions (or a permission screen).

The Administrator can set or reset all of the permissions or a port entry:

- Click **Full Access** to check all permissions.
- Click **No Permissions** to uncheck all permissions.

As with user permissions, port permissions are grouped according to function. There is a **Select All/Clear All** checkbox in each group:

- Check the box to select all of the items in this group.
- Uncheck the box to de-select all of the items in the group.



If a device on a port attempts to edit an item or perform a function that it does not have permission for, an Exception Code 05 is returned.

4.8.6 Import and Export Functions

The Administrator can export and import security settings, including user profiles and port passwords and permissions, to and from an OMNI 4000/7000 flow computer. When using multiple flow computers, the security settings can be configured one time, exported to a file, then imported to the other flow computers.

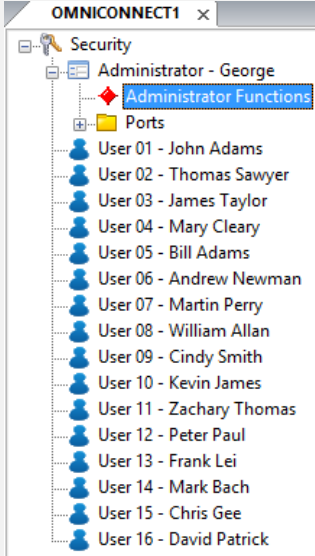
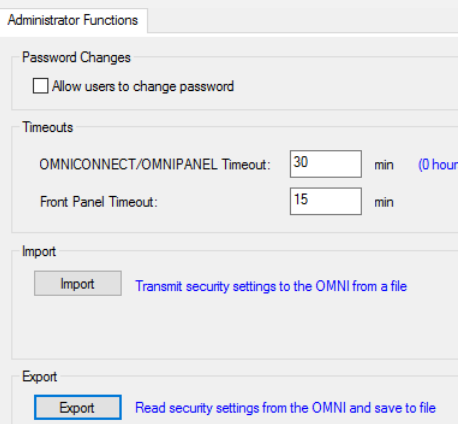
To export and import security settings, follow these instructions:

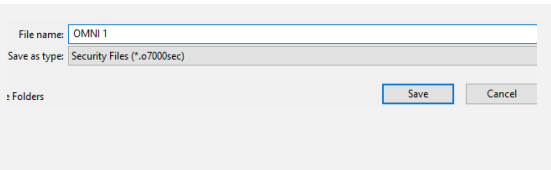
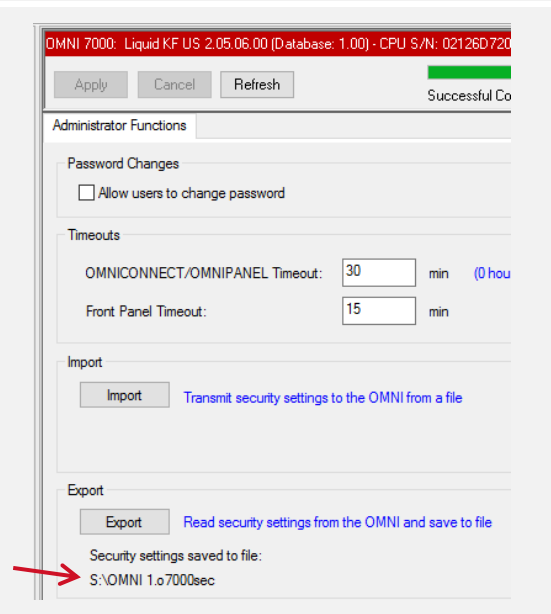
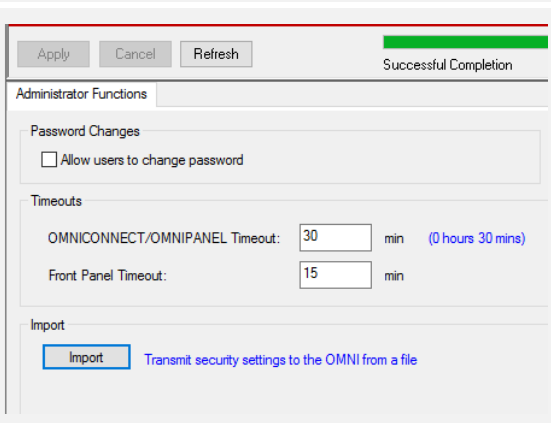
1.	<p>Click the Security button in the Home ribbon to open the Security tree in the left panel.</p>	
2.	<p>In the left panel, expand the tree under Administrator and click Administrator Function.</p>	
3.	<p>Click Export to save the security settings from the flow computer connected to your PC to a file.</p>	

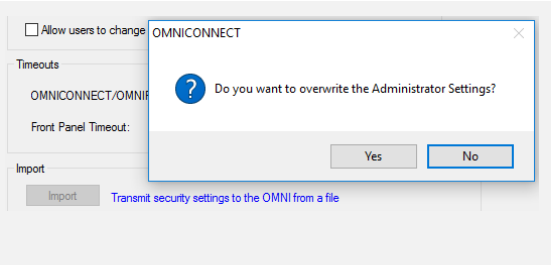
<p>4.</p>	<p>At the prompt, name the file and navigate to a folder. Click Save.</p> <p>The file extension is .o7000sec.</p>	
<p>5.</p>	<p>Verify the security file was saved to the correct location.</p>	
<p>6.</p>	<p>After connecting to a different flow computer, click Import to save the security settings from the file.</p>	
<p>7.</p>	<p>At the prompt, navigate to the folder that contains the file. Select the file to import and click OPEN.</p>	
<p>8.</p>	<p>At the prompt:</p> <ol style="list-style-type: none"> Click No to keep the current Administrator Settings on the flow computer that you are importing security settings to. Click Yes for updating the Administrator Settings to the imported settings. 	

9.

Verify the correct security file was imported.

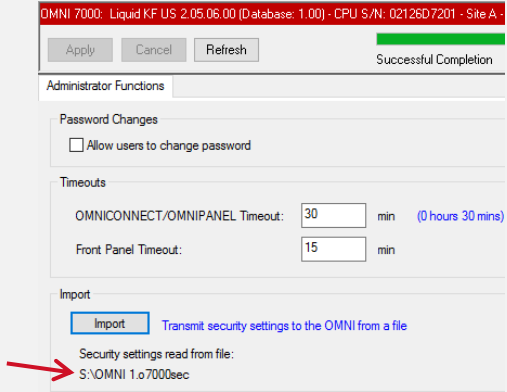

10.

Verify the users and ports security settings imported correctly.

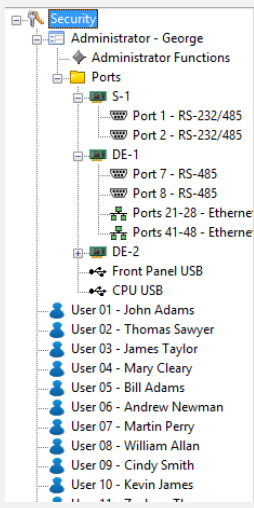

4.8.7 User Password Rules

Enter Password

The password window appears when connecting to an OMNI flow computer from OMNICONNECT or OMNIPANEL. Click the drop-down arrow, and select your User ID from the list of available names. Enter your password and press OK.

The following rules apply to passwords:

- The default timeout for a user password is 30 minutes, but the Administrator can modify the timer.
- If five invalid password attempts are made within a two-minute period, the port will be locked for one minute.



Lost Password

When a user has lost a password, contact the flow computer administrator to retrieve your password. If needed, the administrator will change your password and inform you of the new password.

If the administrator needs further assistance or has lost a password, contact the OMNI Help Desk at helpdesk@omniflow.com.

4.9 Check for Updates

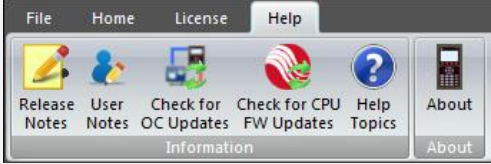
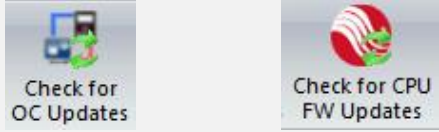
Updates to OMNICONNECT or CPU firmware may have occurred since you received the flow computer. You can automatically check for updates through the Preferences options (Go to Section 4.7.3), or manually check for them at any time through the Help tab. To manually check for updates, follow these instructions:

<p>1.</p>	<p>Click the Help tab on the OMNICONNECT ribbon.</p>	
<p>2.</p>	<p>a. Click the Check for OC Updates to check for OMNICONNECT software releases (go to Step 3). b. Click the Check for CPU Updates button to check for firmware releases (go to Step 4).</p> <div style="border: 1px solid blue; border-radius: 15px; padding: 10px; margin-top: 10px;"> <p>The Release Notes button displays OMNICONNECT software notes from previously installed versions up to and including the current version.</p> </div>	
<p>3.</p>	<p>The OMNICONNECT software release notes include updates and version releases starting from above your currently installed version (they do not include previous versions as with the Release Notes button).</p> <p>If there is a new version to download, go to www.omniflow.com to retrieve it. Follow the instructions and prompts on the activation wizard, as needed.</p>	
<p>4.</p>	<p>The CPU firmware release notes include updates and version releases starting from either above your currently installed version, or above the version you specified in your Preferences in Section 4.7.3.</p> <p>If there is a new version to download, go to www.omniflow.com to retrieve it. Follow the instructions and prompts on the activation wizard, as needed.</p>	

4.10 Configure the OMNI 4000/7000

4.10.1 General Setup

To configure the basic setup information and options, follow these instructions:

- Click the **Configure** button in the Home ribbon to open the **Configure** tree in the left panel.

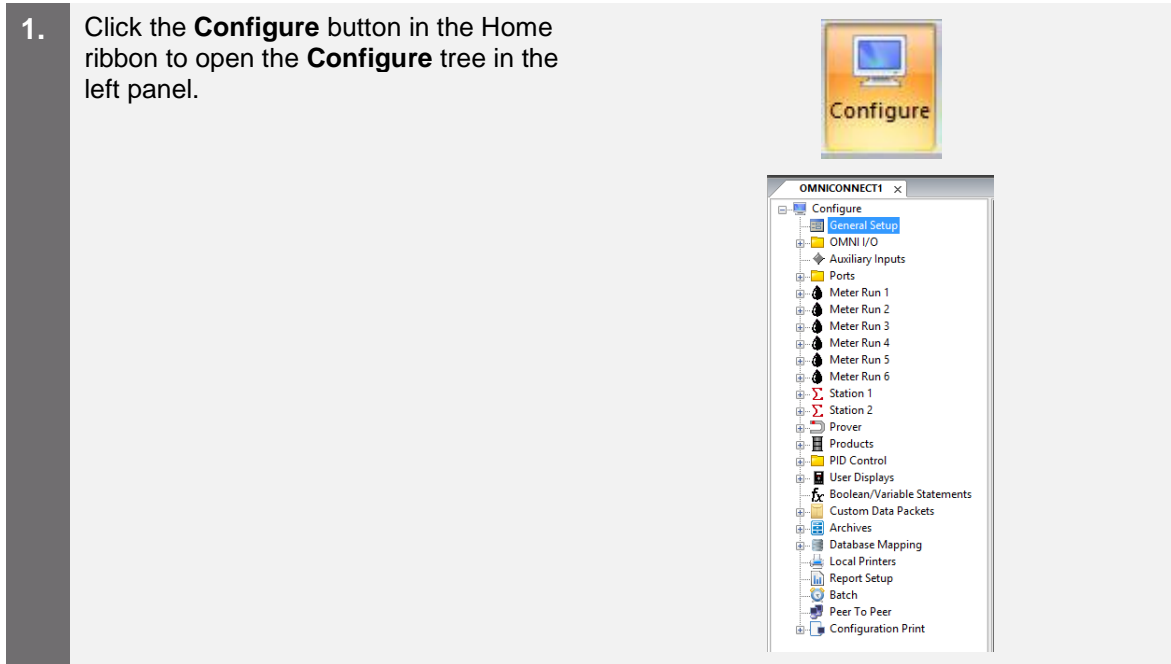

The screenshot shows a 'Configure' button with a computer icon. Below it, a window titled 'OMNICONNECT1' displays a tree view with 'Configure' expanded to show 'General Setup' selected.
- Click the **General Setup** item in the tree in the left panel to display its configuration settings in the screens on the right.

This section of the OMNICONNECT software provides screens for entering a variety of information, such as the OMNI 4000/7000 ID and location and decimal resolution for totalizers and correction factors on batch and prove reports.

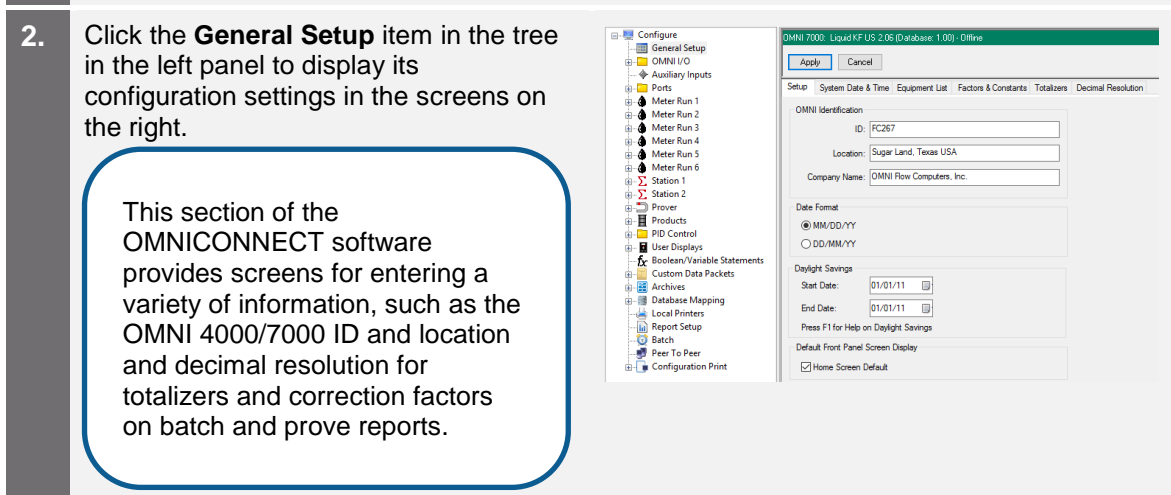

The screenshot shows the 'General Setup' configuration screen. The left panel shows the 'Configure' tree with 'General Setup' selected. The main window displays the 'General Setup' configuration screen with the following fields:

 - OMNI Identification: ID: FC267
 - Location: Sugar Land, Texas USA
 - Company Name: OMNI Flow Computers, Inc.
 - Date Format: MM/DD/YY, DD/MM/YY
 - Daylight Savings: Start Date: 01/01/11, End Date: 01/01/11
 - Default Front Panel Screen Display: Home Screen Default

3.
 - a. Fill in the information in the **General Setup** screens by clicking on each tab.
 - b. Click **Apply** when each screen is complete to apply your changes.

Press F1 to access OMNICONNECT Help for assistance.

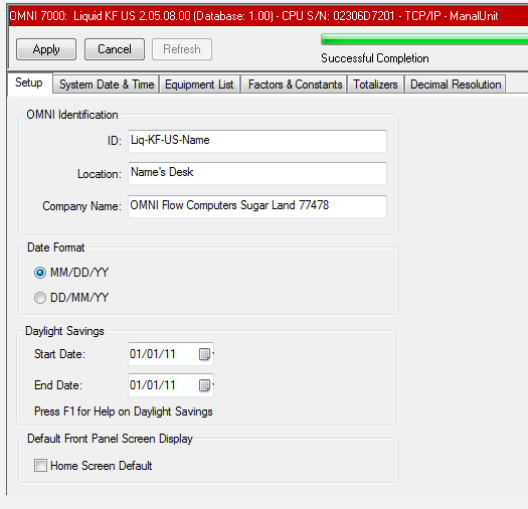

4.10.2 Setup the Equipment List



The **Equipment List** screen is especially important, as these selections control the meter run requirements for specific devices in your system. However, you can come back to this screen at any time during configuration to adjust the list as needed. Any new adjustments may affect other previously configured settings throughout the flow computer.

To set up the Equipment List, follow these instructions:

1. For the **Equipment List** screen, two **Meter Runs** are automatically chosen by default. Add or subtract **Meter Runs** and select their applications, as required.

This example shows the liquids application equipment list. There are no input and output selections for Stations or the Prover in the gas application equipment list.

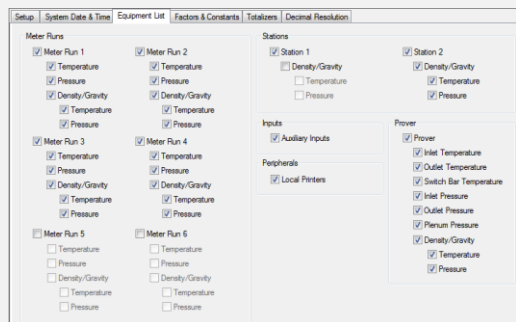

2. After making the necessary selections in the **Equipment List** screen, click the **Apply** button.

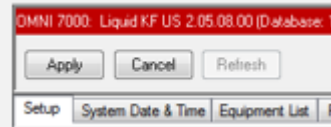

3. After clicking the **Apply** button, verify that the **Meter Runs** you selected in the **Equipment List** now appear in the **Configure** tree in the left panel.

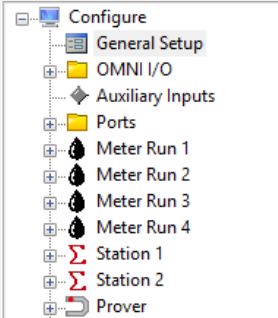

4.10.3 Configure Input and Output Channels

Configure and assign the channels in OMNICONNECT to associate the physical I/O to each installed transducer.

To view all of the modules that are currently installed in your flow computer, follow these instructions:

1. Click the **Configure** button in the Home ribbon to open the **Configure** tree in the left panel.



2. Click the **+** to expand the **OMNI I/O** section in the tree, and then select **Modules**

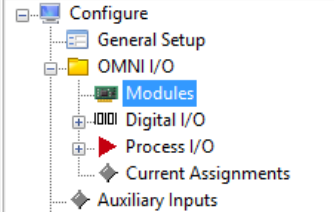

3. This opens the **Modules** screen, where you can review the hardware modules previously installed in the flow computer. Verify the **I/O Allocation** numbers for configuring the **Process Inputs** and **Analog Outputs**.

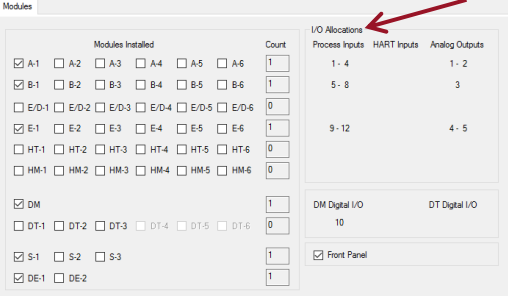

The module selections are read-only and cannot be edited while the flow computer is online.

 Changes to the module configurations and hardware can only be made while offline. However, confirm that any changes you make to the modules and configuration in the offline mode matches the hardware before transmitting the configuration to the flow computer.

Digital I/O Module Configuration



In these instructions, we configure a new DM module. Configuration steps for other types of modules are similar, but the specifics of setup will be different, depending on the particular type of module.

To configure Digital I/Os, follow these instructions:

1.

Click the **Configure** button in the Home ribbon to open the **Configure** tree in the left panel.



2.

Click the **+** to expand the **OMNI I/O** section in the tree.

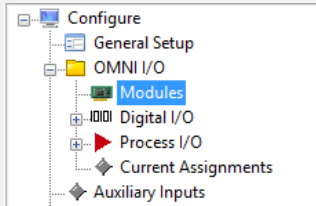

3.

Select and expand the **Digital I/O** section of the tree; then select **DM** to display the configuration settings on the screens to the right.

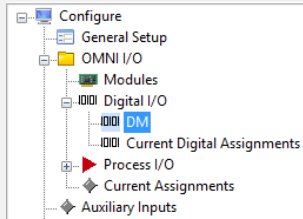

4.

Fill in the required information in this screen.

If you do not already have a Digital I/O assignment, click the **Browser** button (the ellipses) to the right of the **Assign** field to open the **OMNI Database Browser** and to make the database variable assignment.

Press F1 to access OMNICONNECT Help for assistance.

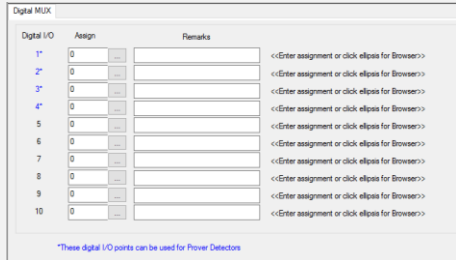

*These digital I/O points can be used for Prover Detectors

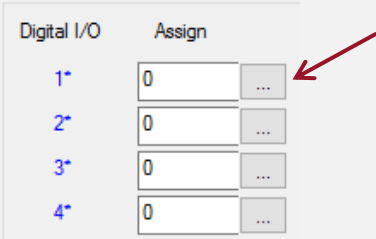



The **OMNI Database Browser** is available to assist with selecting the assignments. Digital I/Os can be assigned as:

- Status or Command inputs.
- Accumulator or Pulse outputs.
- Control Outputs.

The **OMNI Database Browser** is a comprehensive list of database registers that can be assigned to I/O channels. Search the database using keywords or register numbers.

Category and **Data Type** filters allow you to reduce the number of results to those specific to your needs.

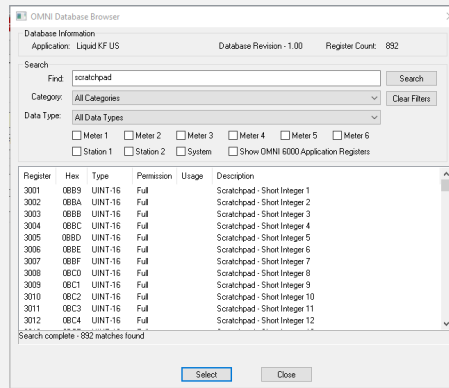

5. After you have finished making your selections and entering the parameters, click the **Apply** button.

When in the online mode, OMNICONNECT will immediately send the configuration changes to the flow computer

6. Click **Current Digital Assignments** in the tree in the left panel. You should now see a summary of the changes you applied in the previous **DM** screen.

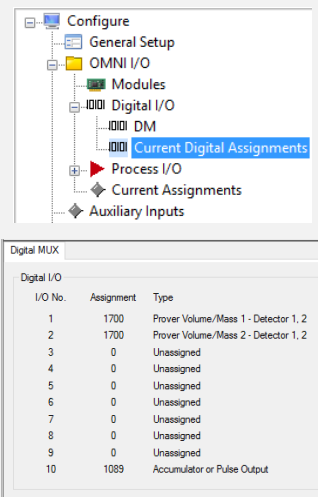

Process I/O Module Configuration



In these instructions, we configure a new A module. Configuration steps for other types of modules are similar, but the specifics of setup will be different, depending on the particular type of module.

To configure Process I/Os, follow these instructions:

1. Click the **Configure** button in the Home ribbon to open the **Configure** tree in the left panel.



2.
 - a. Click the **+** to expand the **OMNI I/O** section in the tree.
 - b. Select and expand **Process I/O**; then expand the module (in this example, **A-1**).
 - c. Select **Process Inputs** to display the configuration settings on the screens to the right.

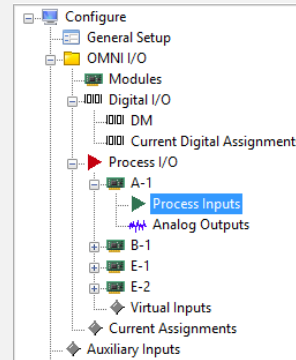

3. Along the top of the screen are tabs for each process input that is available on the module. Fill in the required information in these screens.

Press F1 to access OMNICONNECT Help for assistance.

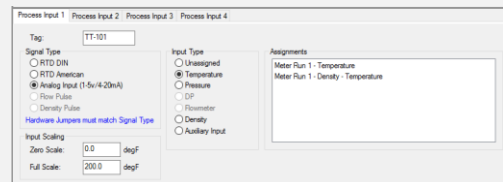

4. After you have finished making your selections and entering parameters for this input, click the **Apply** button to save the configuration.

5. Expand the next module in the tree and select **Process Inputs**. Repeat Steps 3 and 4 for each module.

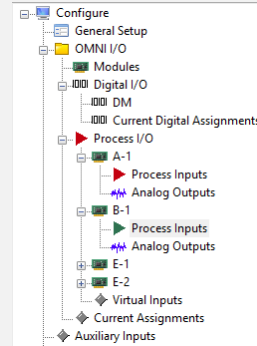

Configure Analog Outputs

Each flow computer module has one or two analog outputs that can be configured to send an analog signal out to other devices, if required.

To configure analog outputs, follow these instructions:

1.
 - a. In the Configure tree in the left panel, select **OMNI I/O**.
 - b. Select **Process I/O**.
 - c. Select the module (**A-1**).
 - d. Select **Analog Outputs**.

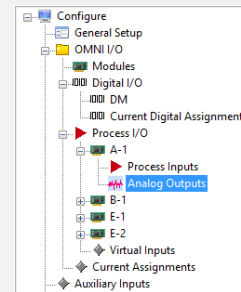

2. With **Analog Outputs** selected in the left panel, the right screen displays the different output configuration options available for this type of module. Fill in the required information in these screens.

Press F1 to access OMNICONNECT Help for assistance.

Analog Output 1

Analog Output 2

Configuration

Assign: ...

Remarks:

Setup

Value at 4mA:

Value at 20mA:

- Click the **Browser** button (the ellipses) to the right of the **Assign** field to open the **OMNI Database Browser** and make a database variable assignment.

Each analog output channel must be assigned a user-selected database variable to be output through the selected analog output. The selected variable will typically be a process variable that is represented in engineering or percentage units.

- Choose the register you want to assign to the output; then click **Select** to assign it.

Register	Hex	Type	Permission	Usage	Description
3001	0BB9	UINT-16	Full		Scratchpad - Short Integer 1
3002	0BBA	UINT-16	Full		Scratchpad - Short Integer 2
3003	0BBB	UINT-16	Full		Scratchpad - Short Integer 3
3004	0BBC	UINT-16	Full		Scratchpad - Short Integer 4
3005	0BBD	UINT-16	Full		Scratchpad - Short Integer 5
3006	0BBE	UINT-16	Full		Scratchpad - Short Integer 6
3007	0BBF	UINT-16	Full		Scratchpad - Short Integer 7
3008	0BC0	UINT-16	Full		Scratchpad - Short Integer 8
3009	0BC1	UINT-16	Full		Scratchpad - Short Integer 9
3010	0BC2	UINT-16	Full		Scratchpad - Short Integer 10
3011	0BC3	UINT-16	Full		Scratchpad - Short Integer 11
3012	0BC4	UINT-16	Full		Scratchpad - Short Integer 12

- After you have finished making your selections and entering parameters for this output, click the **Apply** button to save the configuration.

- Expand the next module in the tree and select **Analog Output**. Repeat Steps 2 through 5 for each module, as needed.

4.10.4 Configure Ports

Depending on the modules installed in the flow computer, the ports may have already been set up and configured (Sections 4.3.1 and 4.3.2). However, you can now use OMNICONNECT™ to edit the settings for those ports or configure any ports that have not been configured up until this point.



CAUTION: Do not edit the settings for an active serial or Ethernet port that you are currently connected to as this could disrupt the active connection to the flow computer.



You cannot edit the settings for the front panel USB or the CPU USB.

To configure ports, follow these instructions:

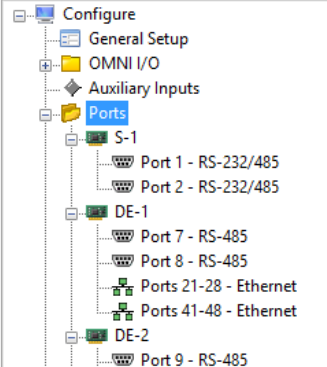
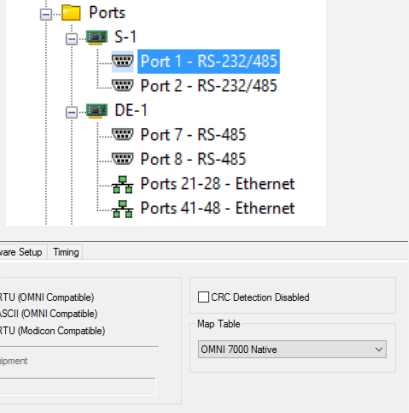
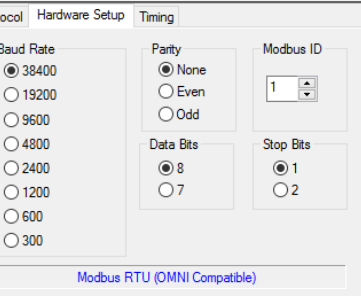
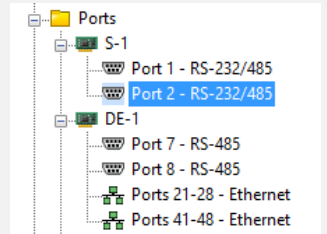
<p>1.</p>	<p>Select Ports in the Configure tree in the left panel and expand the list to see all the different modules and ports on the flow computer.</p>	
<p>2.</p>	<p>Select a serial port in the tree to display its settings on the right screen.</p> <p>If the port was previously configured, these settings will already be established. Verify the settings in the flow computer.</p> <ol style="list-style-type: none"> If the settings do not need adjusting, go to Step 4. If the settings need to be adjusted, go to Step 3. 	
<p>3.</p>	<p>If the port was not previously configured or does not match the settings in the flow computer, make the required selections in the screens on the right to configure the port.</p> <p>Click Apply after you complete each screen to save your changes.</p> <div style="border: 1px solid blue; border-radius: 10px; padding: 5px; width: fit-content; margin: 10px auto;"> <p>Press F1 to access OMNICONNECT Help for assistance.</p> </div>	
<p>4.</p>	<p>Continue selecting each serial port as you move down the Configure tree to either:</p> <ol style="list-style-type: none"> Verify its settings (Step 2). Configure its settings (Step 3). 	

5. For Ethernet ports, under **DE-1** click an Ethernet port then click **Configure DE** to view the **Ethernet Configuration** window.

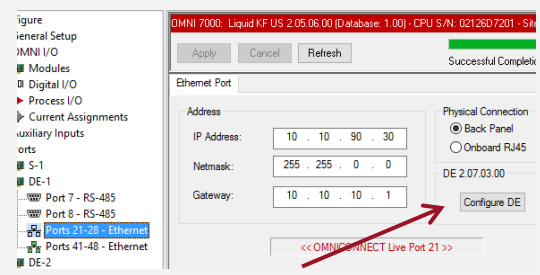

6. The **Ethernet Configuration** window houses advanced Ethernet port configuration options. For network printer setup, go to Section 4.10.8 Configure a Printer.

Fill in the necessary information in the screens for each tab.

- When you complete all tabs, click OK on any tab.
- Click **Apply** to save your changes.

Press F1 for OMNICONNECT Help for the details on the information and parameters needed for each tab.

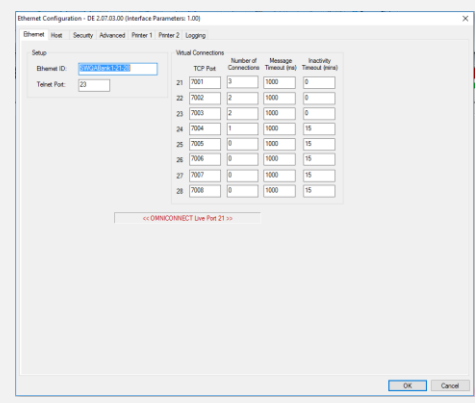

7. Continue selecting and completing fields for each Ethernet port as you move down the **Configure** tree.

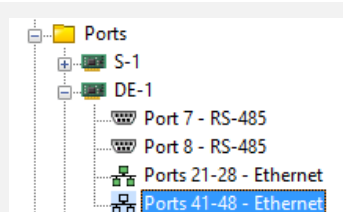

4.10.5 Assign I/O to a Meter Run

After the modules are configured with the proper settings, assign the inputs to a meter run or prover process variable, as applicable:

 Depending on the selections made in the **Equipment List in General Setup** (Section 4.10.1 General Setup), not all four items of the Meter Runs may be described in these instructions.

Meter Runs for flow computers that are configured for gas applications will have different configuration settings.

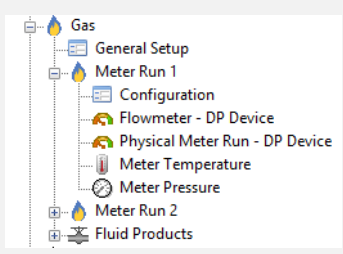

To assign input to a meter run, follow these instructions:

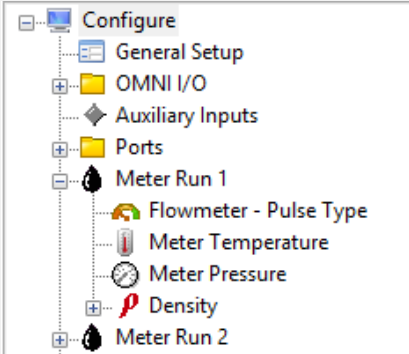
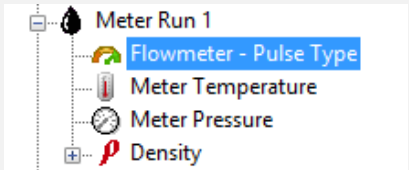
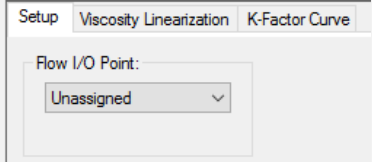
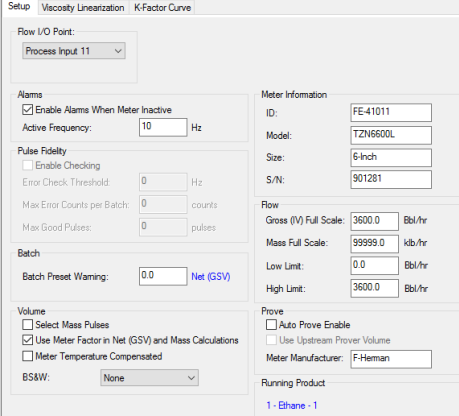
<p>1.</p>	<p>In the Configure tree in the left panel, expand the first Meter Run to see all items.</p>	
<p>2.</p>	<p>Select Flowmeter - Pulse Type to display its configuration options.</p>	
<p>3.</p>	<p>On the Setup tab, select a Flow I/O Point using the drop-down box.</p>	
<p>4.</p>	<p>Fill in the remaining information in the Flowmeter screens for each tab.</p> <div style="border: 1px solid blue; border-radius: 15px; padding: 10px; width: fit-content; margin: 10px auto;"> <p>Press F1 to access OMNICONNECT Help for assistance.</p> </div>	



On the **Setup** screen, if you choose **Select Mass Pulses** the **Viscosity Linearization** tab is deactivated and the **Reynolds Correction** and **Reynolds MF Curve** tabs become available to use. These configurations are optional for certain types of Coriolis meters.



On the **Reynolds Correction** tab, select the **Use Reynolds Correction** check box if the correction is required for your meter. The supported meter model numbers are listed in the **Meter Model** drop-down box.

The **Reynolds MF Curve** tab has the entry fields for the Meter Factors, Reynolds Numbers, and Flow Rates for each curve data point. The Flow Rate settings are for informational purposes only, and are not used in the calculations.

Point	Meter Factor	Reynolds Number	Flow Rate
1	1.100000	10.0	0.0 Tonne/hr
2	1.000000	100.0	0.0 Tonne/hr
3	0.980000	1000.0	0.0 Tonne/hr
4	0.900000	10000.0	0.0 Tonne/hr
5	0.000000	0.0	0.0 Tonne/hr
6	0.000000	0.0	0.0 Tonne/hr
7	0.000000	0.0	0.0 Tonne/hr
8	0.000000	0.0	0.0 Tonne/hr
9	0.000000	0.0	0.0 Tonne/hr
10	0.000000	0.0	0.0 Tonne/hr
11	0.000000	0.0	0.0 Tonne/hr
12	0.000000	0.0	0.0 Tonne/hr

For detailed information on configuring the Reynolds correction for a meter, refer to OMNICONNECT Help.

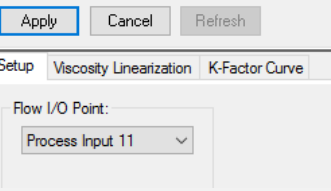
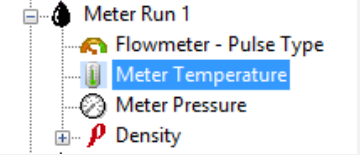
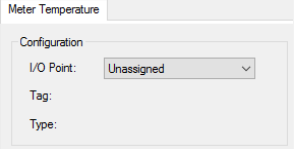
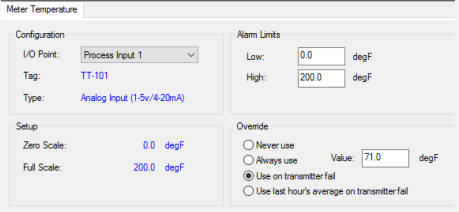
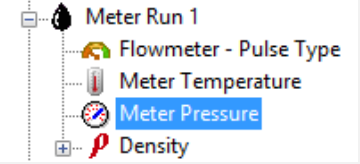
Press F1 to access OMNICONNECT Help for assistance.

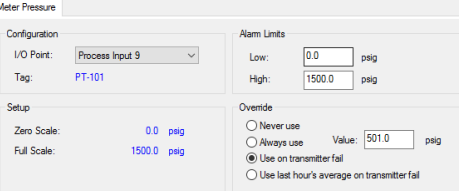
<p>5.</p>	<p>After you complete each screen, click Apply to save your changes.</p>	
<p>6.</p>	<p>Select Meter Temperature to display the configuration options.</p>	
<p>7.</p>	<p>Select an I/O Point using the drop-down box.</p>	
<p>8.</p>	<p>a. Fill in the remaining information in the Meter Temperature screen. b. When you are finished, click Apply to save the changes.</p> <div style="border: 1px solid blue; border-radius: 15px; padding: 10px; margin-top: 10px;"> <p>Press F1 to access OMNICONNECT Help for assistance.</p> </div>	
<p>9.</p>	<p>Select Meter Pressure to display its configuration options.</p>	
<p>10.</p>	<p>Select an I/O Point using the drop-down box.</p>	
<p>11.</p>	<p>a. Fill in the remaining information in the Meter Pressure screen. b. When you are finished, click Apply to save the changes.</p> <div style="border: 1px solid blue; border-radius: 15px; padding: 10px; margin-top: 10px;"> <p>Press F1 to access OMNICONNECT Help for assistance.</p> </div>	

12. a. Select and expand **Density** or **Density/Gravity** to display its configuration options.
- b. Configure the associated **Temperature** and **Pressure** items if either is included in your meter run.

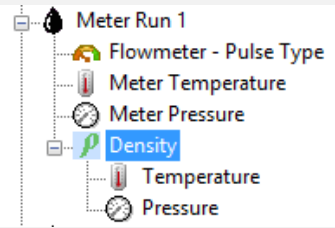

When a Density is configured, a Density Temperature and a Density Pressure input channel should also be configured, even if they share the same input channels as the Meter Temperature and Meter Pressure.

13. In the main **Density** or **Density/Gravity** display screen, select an **I/O Point** using the drop-down box and fill in the remaining information on the other screens, as needed.

14. a. Under **Density** or **Density/Gravity**, select **Temperature**. Select an **I/O Point**, and fill in the information in the **Temperature** screen.
- b. When you are finished, click **Apply** to save the changes.

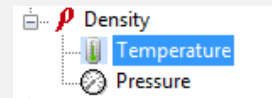

Press F1 to access OMNICONNECT Help for assistance.

15. a. Under **Density** or **Density/Gravity**, select **Pressure**. Select an **I/O Point** and fill in the information in the **Pressure** screen.
- b. When you are finished, click **Apply** to save the changes.

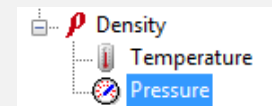

16. Continue selecting and completing fields for each meter run as you move down the **Configure** tree.

4.10.6 Configure Products

Liquids

To configure liquid products if your flow computer is configured for liquid applications, follow these instructions:

- 1.** Select **Products** in the **Configure** tree in the left panel and expand the item to see the entire list of products.

For liquid applications, there are up to 32 configurable products. You do not have to use or configure all of them.

- 2.**



 - a. Select a product in the tree to display its configuration options in the screens on the right.
 - b. Fill in the information in the screens for all three tabs, as necessary.
 - c. When you are finished, click **Apply** to save the changes.

Press F1 to access OMNICONNECT Help for assistance.

- 3.** Continue selecting each product as you move down the **Configure** tree to configure its settings, as needed.

Gas

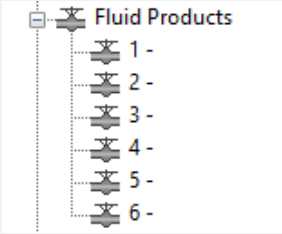
To configure gas fluid products if the flow computer is configured for gas applications, follow these instructions:

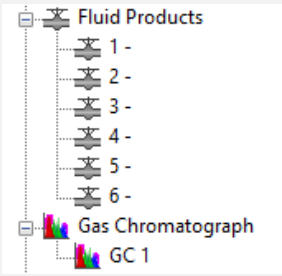
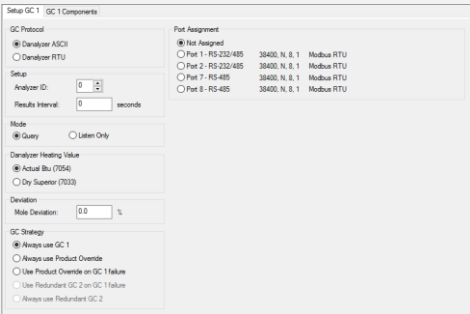
<p>1.</p>	<p>Select Fluid Products in the Configure tree in the left panel, and expand the list to see the entire list of products.</p> <div data-bbox="386 443 852 625" style="border: 1px solid blue; border-radius: 15px; padding: 10px; margin: 10px 0;"> <p>For gas applications, there are six default products. You do not have to use or configure all of them.</p> </div>	
<p>2.</p>	<p>a. Select a product in the tree to display its configuration options in the screens on the right. b. Fill in the information in the screens for both tabs, as needed. c. When you are finished, click Apply to save the changes.</p> <div data-bbox="386 888 868 1031" style="border: 1px solid blue; border-radius: 15px; padding: 10px; margin: 10px 0;"> <p>Press F1 to access OMNICONNECT Help for assistance.</p> </div>	
<p>3.</p>	<p>Continue selecting each fluid product as you move down the Configure tree to configure its settings, as needed.</p>	
<p>4.</p>	<p>If the flow computer is equipped with a gas chromatograph (selected on the Equipment List screen in Section 4.10.1), select and expand Gas Chromatograph on the tree.</p> <p>Select GC 1 to display its configuration settings in the screens on the right.</p>	
<p>5.</p>	<p>a. Fill in the information in both gas chromatograph screens. b. When you are finished, click Apply to save the changes.</p> <div data-bbox="386 1602 868 1745" style="border: 1px solid blue; border-radius: 15px; padding: 10px; margin: 10px 0;"> <p>Press F1 to access OMNICONNECT Help for assistance.</p> </div>	
<p>6.</p>	<p>Repeat these steps for GC 2 if you have a second gas chromatograph.</p>	

4.10.7 Configure Provers

If you selected a prover as part of the flow computer's Equipment List set up in Section 4.10.2 Setup the Equipment List, it will appear in the Configure tree in the left panel. You must configure the prover if you intend to use the function in the future.

To configure the prover settings for liquid applications, follow these instructions:

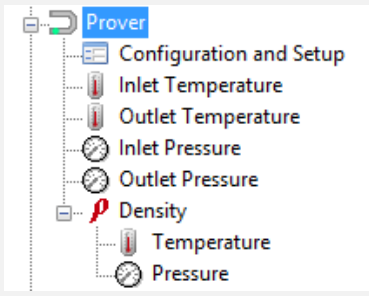
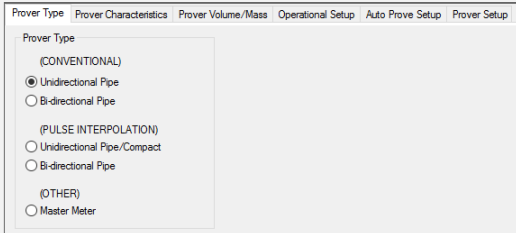
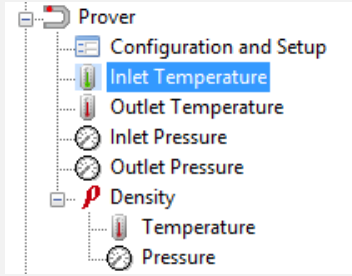
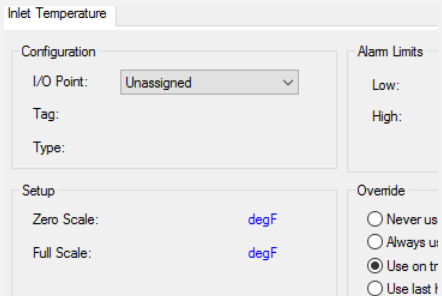
<p>1.</p>	<p>a. Select and expand the Prover function in the Configure tree in the left panel.</p> <p>b. Select Configuration and Setup to display the Prover configuration options in the screens on the right.</p> <div data-bbox="386 598 868 777" style="border: 1px solid blue; border-radius: 15px; padding: 5px; margin-top: 10px;"> <p>Depending on which options you selected in the Equipment List in Section 4.10.1, you may not see all of the items listed here.</p> </div>	
<p>2.</p>	<p>a. Fill in the information in all of the screens, as necessary.</p> <p>b. When you have finished with each screen, click Apply to save the changes.</p> <div data-bbox="386 955 868 1102" style="border: 1px solid blue; border-radius: 15px; padding: 5px; margin-top: 10px;"> <p>Press F1 to access OMNICONNECT Help for assistance.</p> </div>	
<p>3.</p>	<p>When all of the Configuration and Setup screens are completed and their changes have been saved, click the next item in the Prover list (in this example, Inlet Temperature).</p>	
<p>4.</p>	<p>The Inlet Temperature configuration settings are displayed in the screen on the right. Assign an I/O Point from the Unassigned drop-down box. Fill in the remaining information, as necessary.</p> <div data-bbox="386 1585 868 1732" style="border: 1px solid blue; border-radius: 15px; padding: 5px; margin-top: 10px;"> <p>Press F1 to access OMNICONNECT Help for assistance.</p> </div>	

5. When you have finished with the screen, click **Apply** to save the changes.
6. Continue to move down and configure all of the items listed under **Prover** in the **Configure** tree by repeating Steps 3 through 5, as necessary.

4.10.8 Configure a Printer

To configure a local RS-232 serial printer or Ethernet network printer, follow the applicable set of instructions.

Serial Local Printer

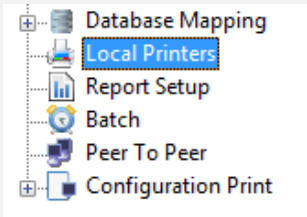
1. Select the **Local Printers** function in the **Configure** tree in the left panel to display its configuration settings in the screen on the right.
 
2. Fill in the information in the fields for a **Local Printer** screen, as necessary.

Press F1 to access OMNICONNECT Help for assistance.

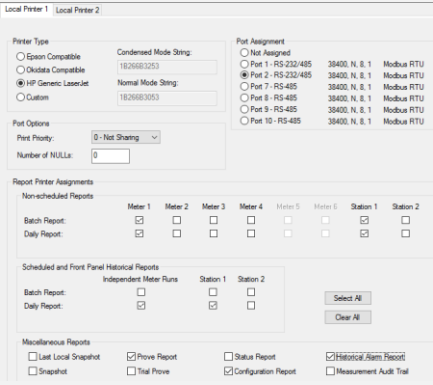

3. When you have finished with the screen, click **Apply** to save the changes.
4. Repeat for additional **Local Printer** screens.

Ethernet Network Printer

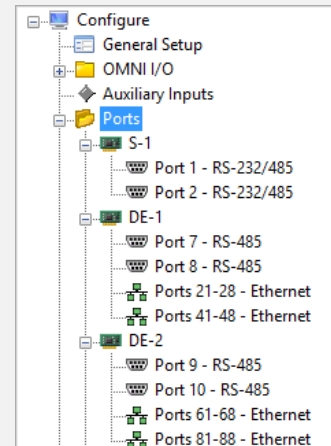
1. Click and expand **Ports** in the **Configure** tree in the left panel to display its configuration settings in the screen on the right.

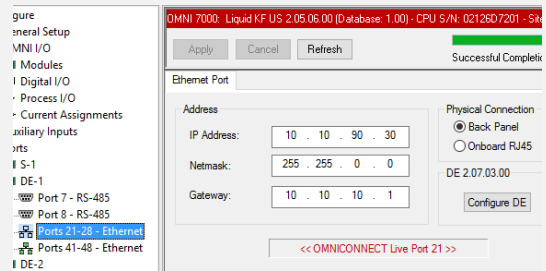

2. Under **DE-1**, click an Ethernet port to view the **Ethernet Configuration** window.



3.
 - a. Check **Physical Connection** to confirm the location of the Ethernet port you want to use for the printer.
 - b. Click **Configure DE** to view the **Ethernet Configuration** window.

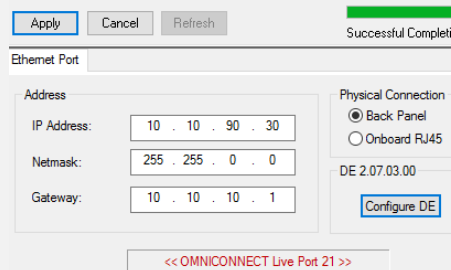

4. Fill in the information in the fields for a **Printer** screen, as necessary.

Press F1 to access OMNICONNECT Help for assistance.

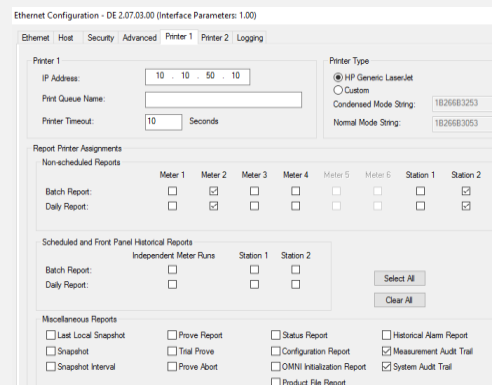

5. Complete setup for additional **Printer** screens.
Click **OK** when all network printers are configured.

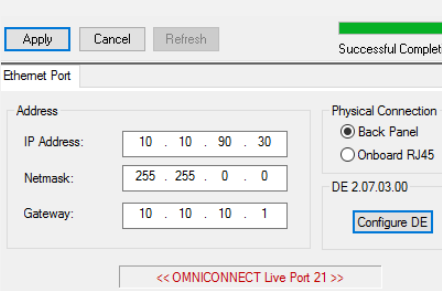
<p>6.</p>	<p>Click Apply to complete the configuration.</p>	
<p>7.</p>	<p>Continue selecting and completing fields for each Ethernet port as you move down the Configure tree.</p>	

4.10.9 Configure Report Setup

To select the report templates for the flow computer, follow these instructions:

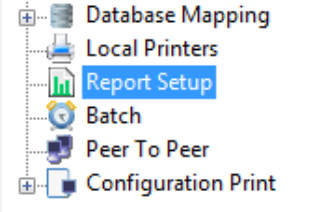
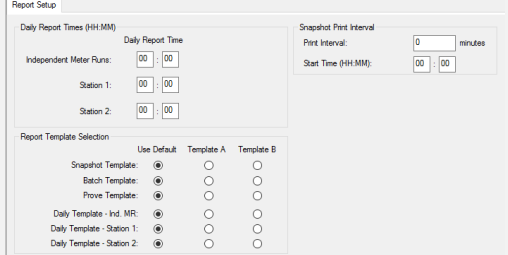
<p>1.</p>	<p>Select the Report Setup function in the Configure tree in the left panel to display its configuration settings in the screen on the right.</p>	
<p>2.</p>	<p>a. Fill in the information in all of the fields, as necessary.</p> <p>b. When you have finished with each screen, click Apply to save the changes.</p>	

Press F1 to access OMNICONNECT Help for assistance.

4.10.10 Configure Batch

To select the batch parameters for the flow computer meter runs, follow these instructions:

1.

Select the **Batch** function in the **Configure** tree in the left panel to display its configuration settings in the screen on the right.

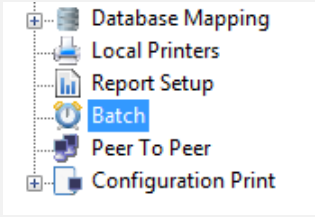

2.

Fill in the information in the **Batch Setup** and **Batch Scheduling** screens, as necessary.

Press F1 to access OMNICONNECT Help for assistance.

Batch Setup Batch Scheduling

Independent Meter Runs

Batch Preset Units

Net (GSV)

Gross (IV)

Mass

Batch Start

Start batch only when the meter becomes active

Start batch with current date/time even if the meter is inactive and update start date/time when the meter becomes active

Start batch with current date/time even if the meter is inactive

Station 1

Batch Preset Units

Net (GSV)

Gross (IV)

Mass

Batch Start

Start batch when any Station 1 meter becomes active

Start batch with current date/time even if all Station 1 meters are inactive and update start date/time when any Station 1 meter becomes active

Start batch with current date/time even if all Station 1 meters are inactive

Batch Stack

Use Common Batch Stack

[Press F1 for Help on Common Batch Stacks](#)

Station 2

Batch Preset Units

Net (GSV)

Gross (IV)

Mass

Batch Start

Start batch when any Station 2 meter becomes active

Start batch with current date/time even if all Station 2 meters are inactive and update start date/time when any Station 2 meter becomes active

Start batch with current date/time even if all Station 2 meters are inactive

Batch Stack

Use Common Batch Stack

[Press F1 for Help on Common Batch Stacks](#)

3.

When you have finished with each screen, click **Apply** to save the changes.

4.10.11 Peer to Peer Protocol

In Peer to Peer Mode, the host computer is in Master Mode and passes mastership from one flow computer to the next. This allows each flow computer to process its own transactions. Refer to the Technical Bulletin TB-980401B Peer to Peer Basics.

In Active Redundancy Mode, one computer is selected as the duty flow computer and the other on standby as backup in case of failure of the duty flow computer. The flow computers share measurement responsibility and process signals. Refer to the Technical Bulletin TB-980402C Using the Peer to Peer Function in a Redundant Flow Computer Application.

To set up a series of flow computers to operate in Peer to Peer or Active Redundancy Mode, follow these instructions:

1. Select the **Peer to Peer** function in the **Configure** tree in the left panel to display its configuration settings in the screen on the right.

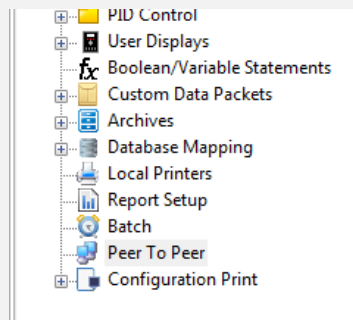

2. Fill in the information in the **Setup** and screen as necessary.

Press F1 to access OMNICONNECT Help for assistance.

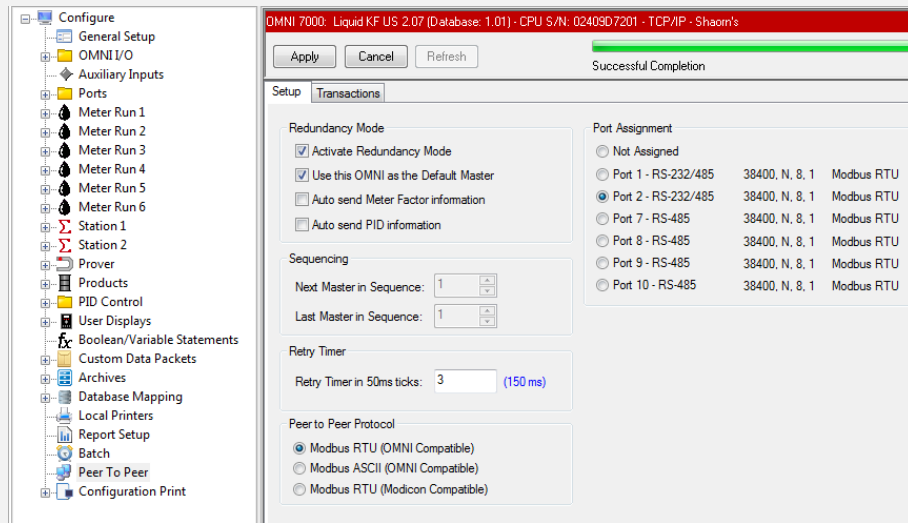

3. When you have finished, click **Apply** to save the changes.

4. Complete the assignments in the **Transactions** screen that will allow the flow computers to exchange data.

Press F1 to access OMNICONNECT Help for assistance.

Slip	Slave ID	Slave Data Type	Operation	Function Code	Source	Point Count	Destination
1	1	8-byte ASCII string	Read	Default Function Code	4947	4	4015
2	1	16-bit unsigned integer	Read	Default Function Code	3853	1	3015
3	1	16-bit unsigned integer	Write	Default Function Code	3844	1	3524
4	1	32-bit unsigned integer	Read	Default Function Code	5109	2	5715
5	1	32-bit unsigned integer	Write	Default Function Code	5109	2	5524
6	1	Float	Read	Default Function Code	7100	2	40515
7	1	Float	Write	Default Function Code	7101	2	7524
8	3	8-byte ASCII string	Read	Default Function Code	4835	4	4031
9	1	8-byte ASCII string	Read	Default Function Code	4947	4	4015
10	1	16-bit unsigned integer	Read	Default Function Code	3853	1	3015
11	1	16-bit unsigned integer	Write	Default Function Code	3844	1	3524
12	1	32-bit unsigned integer	Read	Default Function Code	5109	2	5715
13	1	32-bit unsigned integer	Write	Default Function Code	5109	2	5524
14	1	Float	Read	Default Function Code	7100	2	40515
15	1	Float	Write	Default Function Code	7101	2	7524
16	3	8-byte ASCII string	Read	Default Function Code	4835	4	4031
17	1	8-byte ASCII string	Read	Default Function Code	4947	4	4015
18	1	16-bit unsigned integer	Read	Default Function Code	3853	1	3015
19	1	16-bit unsigned integer	Write	Default Function Code	3844	1	3524
20	1	32-bit unsigned integer	Read	Default Function Code	5109	2	5715
21	1	32-bit unsigned integer	Write	Default Function Code	5109	2	5524
22	1	Float	Read	Default Function Code	7100	2	40515
23	1	Float	Write	Default Function Code	7101	2	7524
24	3	8-byte ASCII string	Read	Default Function Code	4835	4	4031
25	1	8-byte ASCII string	Read	Default Function Code	4947	4	4015
26	1	16-bit unsigned integer	Read	Default Function Code	3853	1	3015
27	1	16-bit unsigned integer	Write	Default Function Code	3844	1	3524

5. When you have finished, click **Apply** to save the changes.



Up to 100 transactions can be selected.

5. Calibration

After configuring the flow computer, calibrate the analog inputs and outputs using either the front panel or the Diagnostics and Calibration menu in OMNICONNECT.

Follow the temperature stability requirements of electrical equipment (such as current generators, voltage generators, digital voltmeters) used during the calibration process.

To help ensure accurate calibration measurements, follow these guidelines:

- Keep the flow computer closed to retain internal heat when calibrating the standard panel mount models.
- Verify that the flow computer is not in a high air draft area (for example, in the path of a fan or AC duct), and allow sufficient time for the temperature to stabilize.
- If it is necessary to replace a hardware module, allow 20 minutes for the temperature to stabilize.

5.1 Calibrate Using the Front Panel

Access the calibration tools through the front panel of the OMNI 4000/7000 flow computer.



For initial calibration, the Input Verification and Output Verification menu selections are not used.

5.1.1 Input Calibration



The options to calibrate by variable name (for example, 'Temperature'), will not be selectable under the six individual meters or the two stations or the prover until input channels have been assigned to them in OMNICONNECT.

To calibrate the input channels, follow these instructions:

<p>1.</p>	<p>a. From the Home screen on the front panel display, use the arrow keys to navigate to and select Utilities.</p> <p>b. Press the OK key or the Enter key on the front panel.</p>	
<p>2.</p>	<p>a. On the Utilities screen, use the arrow keys to navigate to the Calibration menu selection.</p> <p>b. Press OK or Enter.</p>	

3. With **Input Calibration** highlighted, press **OK** or **Enter**.

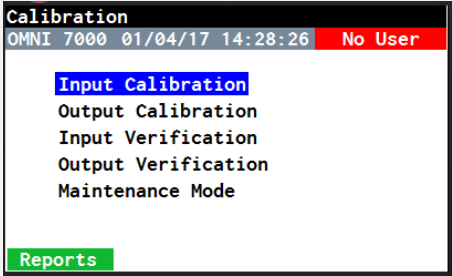

The screenshot shows a terminal window titled "Calibration". At the top, it displays "OMNI 7000 01/04/17 14:28:26 No User". The main menu lists several options: "Input Calibration" (highlighted in blue), "Output Calibration", "Input Verification", "Output Verification", and "Maintenance Mode". A green "Reports" button is visible at the bottom left of the menu area.

 The **Process Input Calibration** screen includes a horizontal Input bar at the top with these options:

- Process Input (PI) allows you to calibrate by channel number selection (for example, 1 through 32).
- Numbers 1 through 6 allow you to calibrate using a process input variable name for individual Meters 1 through 6 (for example, Meter 1 Temperature or Meter 5 Density Pressure).
- S1 and S2 allow you to calibrate using a process input variable name for Individual Station 1 and Station 2 (for example, Station 1 Density Temperature or Station 2 Density Pressure).

4. Use the arrow navigation keys to select an option on the **Input** bar; then press **OK**.

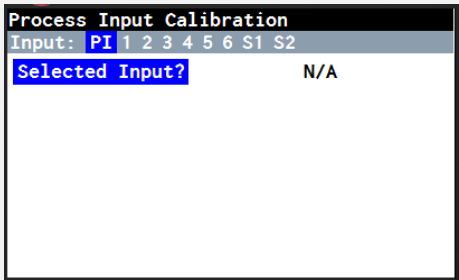

The screenshot shows a terminal window titled "Process Input Calibration". The "Input:" bar is highlighted in blue and contains the options "PI 1 2 3 4 5 6 S1 S2". Below this, the text "Selected Input?" is displayed in blue, followed by "N/A".

 If you are not already logged in to the flow computer, you may be prompted to enter your user ID and PIN. If user security has not yet been configured in the flow computer, the default factory password for the Administrator is ID=00 PIN=0000.

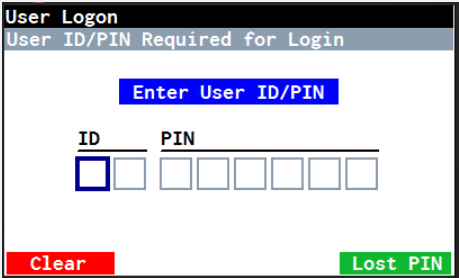

The screenshot shows a terminal window titled "User Logon". Below the title, it says "User ID/PIN Required for Login". A blue button labeled "Enter User ID/PIN" is centered. Below this, there are two input fields: "ID" and "PIN". The "ID" field has a blue cursor and contains "00". The "PIN" field contains "0000". At the bottom, there are two buttons: a red "Clear" button and a green "Lost PIN" button.

5. Use the **Up** or **Down** arrow navigation keys to scroll through the available channels or variables to calibrate.
- Press **OK** or the **Accept** function key to continue.
- Press the **Cancel** function key to abort the calibration process.

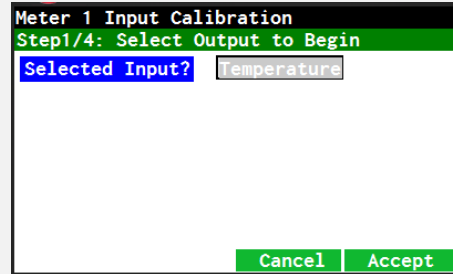
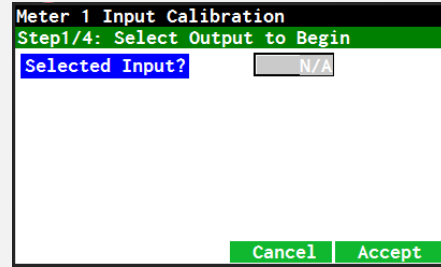

6. Use the **Up** or **Down** arrow navigation keys to scroll to each field.
- Press **OK** to enter the edit mode for the selected field, and edit the values or selections as needed:
- Choose the **Calibration Units** from the drop-down list (for example, mA, Ohms).
 - Type in the desired **Override Value** in engineering units.

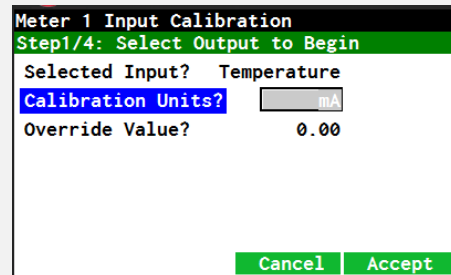

After editing each field, press **OK** or the **Accept** function key to continue.



- **Selected Input?** displays the channel number or process variable name selected for calibration.
- **Calibration Units?** appears only after an input has been selected.
- **Override Value?** will not appear under the PI menu selection if the channel number has not yet been assigned in the flow computer configuration. The flow computer will use the engineering value in its flow calculations while the input channel is being calibrated.

7. Verify that the signal wiring is properly connected to the appropriate input channel at the Terminal Block on the flow computer back panel.

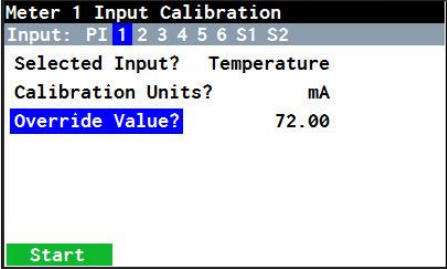
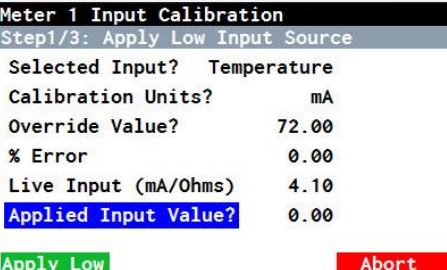
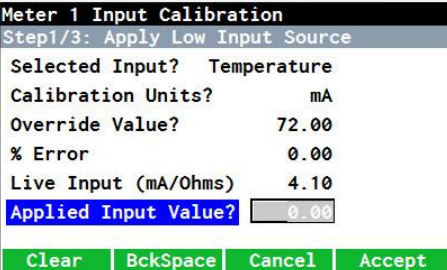
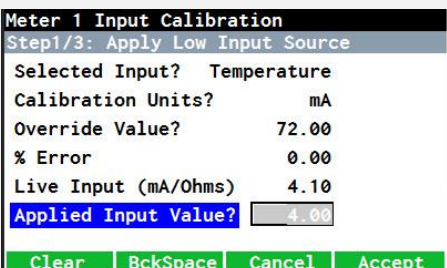
<p>8.</p>	<p>Press the Start function key to begin the calibration.</p>	
<p>9.</p>	<p>Adjust the Signal Generator or configure the Transmitter (whichever is connected) to output the appropriate Low value according to the selected calibration units.</p> <div style="border: 1px solid blue; border-radius: 15px; padding: 10px; margin: 10px 0;"> <p>Low values are 4.00 mA for a 4–20 mA input, 1V for a 1–5V input, and 25 ohms for an RTD input.</p> </div>	
<p>10.</p>	<p>Confirm that the Live Input (mA/Ohms) field value is close to the applied value from the field transmitter or signal generator.</p> <p>If the value is not close to the applied value, check:</p> <ul style="list-style-type: none"> • The wiring is connected to the correct channel. • The hardware jumper settings. 	
<p>11.</p>	<p>Wait 20 to 30 seconds for the readings to stabilize.</p>	
<p>12.</p>	<p>While the Applied Input Value? field is highlighted, press OK.</p>	
<p>13.</p>	<p>Using the numeric keypad, enter a value that exactly matches the value at the field transmitter or the signal generator.</p> <p>Press OK.</p>	

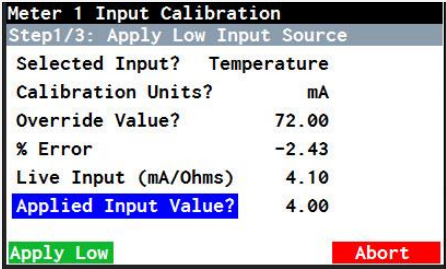
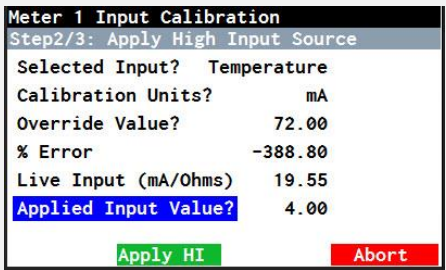
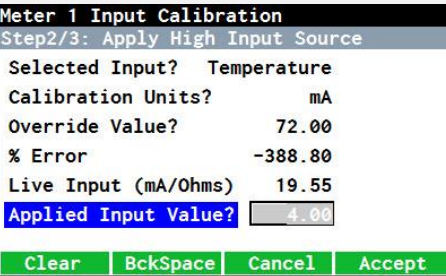
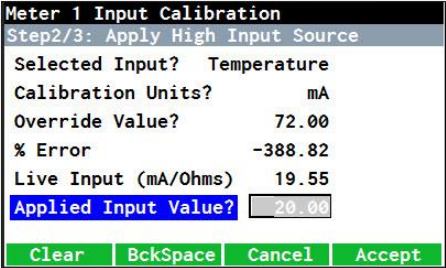
<p>14.</p>	<p>Press the Apply Low function key to complete the Low adjustment or the Abort function key to discard.</p>	
<p>15.</p>	<p>Adjust the Signal Generator or configure the Transmitter, whichever is connected, to output the appropriate HI value according to the selected calibration units.</p> <div style="border: 1px solid black; border-radius: 15px; padding: 10px; margin: 10px 0;"> <p>High values are 20.00 mA for a 4–20 mA input, 5V for a 1–5V input, and 150 ohms for an RTD input.</p> </div>	
<p>16.</p>	<p>Confirm that the Live Input (mA/Ohms) field value in the Apply High Input Source screen is close to the applied value from the field transmitter or signal generator.</p> <p>If the value is not close to the applied value, check:</p> <ul style="list-style-type: none"> • The wiring is connected to the correct channel. • The hardware jumper settings. 	
<p>17.</p>	<p>Wait 20 to 30 seconds for the readings to stabilize.</p>	
<p>18.</p>	<p>While the Applied Input Value? field is highlighted, press OK.</p>	
<p>19.</p>	<p>Using the numeric keypad, enter a value that exactly matches the value at the field transmitter or the signal generator.</p> <p>Press OK.</p>	

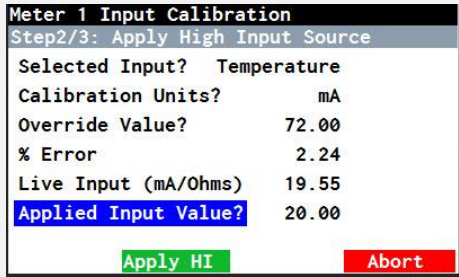
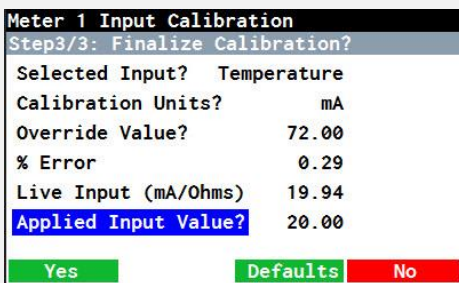
- | | | |
|------------|--|--|
| <p>20.</p> | <p>Press the Apply HI function key to complete the span adjustment or the Abort function key to discard.</p> |  |
| <p>21.</p> | <p>After pressing the Apply HI function key, the Finalize Calibration? screen displays.</p> <ol style="list-style-type: none"> If you have trouble calibrating the input channel, reset the channel by pressing the Defaults function key; then attempt to calibrate the channel again. Press the Yes function key to finalize the calibration of the input channel. Press the No function key to discard the calibration changes. |  |
| <p>22.</p> | <p>Continue calibrating additional input channels as needed by repeating these steps.</p> | |

5.1.2 Output Calibration

To calibrate the 4–20 mA output channels, follow these instructions:

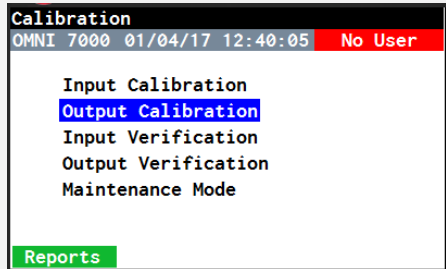
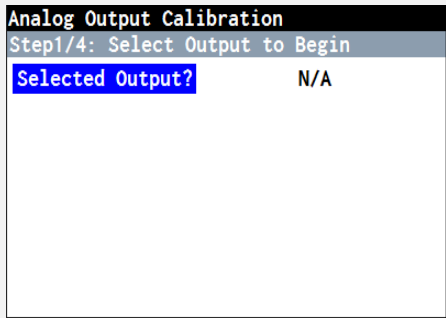
- | | | |
|-----------|---|--|
| <p>1.</p> | <ol style="list-style-type: none"> From the main menu of the front panel, select Utilities and press OK. Select Calibration, press OK. Select Output Calibration. |  |
| <p>2.</p> | <p>Press OK to enter the edit mode of the Selected Output? field.</p> |  |

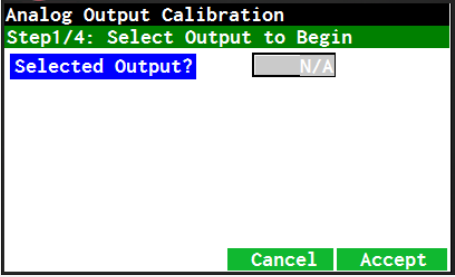
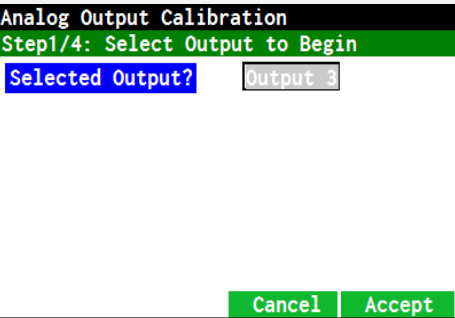
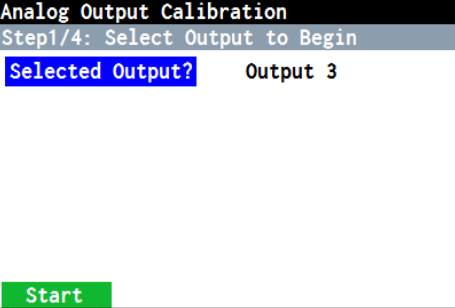
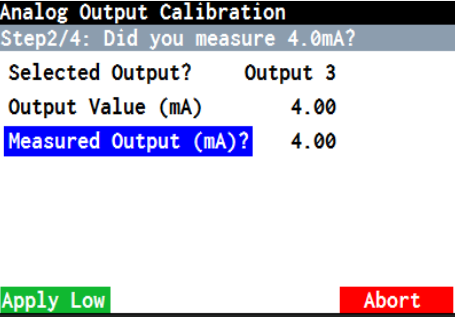
<p>3.</p>	<p>Use the Up or Down arrow keys to scroll through the list of output channels.</p>	
<p>4.</p>	<p>Press the Cancel function key to abort the calibration process, or press OK or the Accept function key to select the highlighted channel.</p>	
<p>5.</p>	<p>Connect an ammeter in series between the flow computer and the external 4–20 mA device.</p>	
<p>6.</p>	<p>Press the Start function key to begin the calibration process.</p>	
<p>7.</p>	<p>Confirm that the next screen shows the Output Value (mA) field default of 4.00.</p>	
<p>8.</p>	<p>Wait 20 to 30 seconds for the readings to stabilize.</p>	
<p>9.</p>	<p>Note the value indicated on the ammeter.</p>	

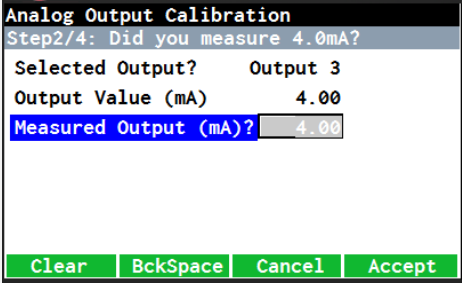
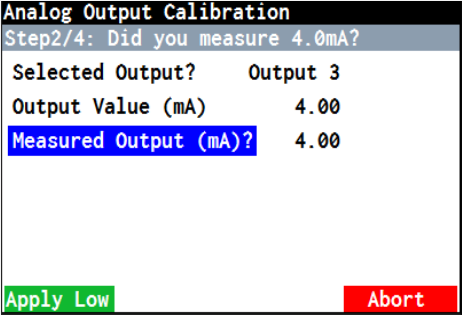
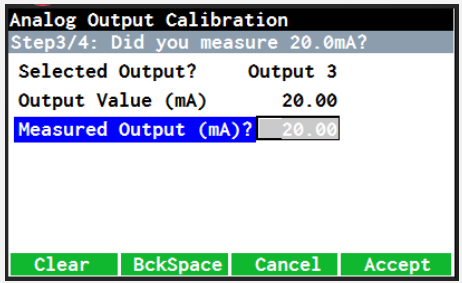
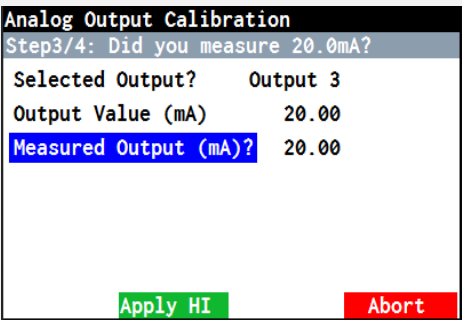
<p>10.</p>	<p>Use the front panel to key in the value that appears on the ammeter:</p> <ol style="list-style-type: none"> Select the Measured Output (mA)? field. Press OK. Enter the value. Press OK again or the Accept function key. 	
<p>11.</p>	<p>If needed, press the Abort function key to cancel the calibration.</p> <p>To continue to the 20-mA calibration screen, press the Apply Low function key.</p> <p>The next screen shows the Output Value (mA) field default of 20.00.</p>	
<p>12.</p>	<p>Wait 20 to 30 seconds for the readings to stabilize.</p>	
<p>13.</p>	<p>Note the value indicated on the ammeter.</p>	
<p>14.</p>	<p>Use the front panel of the flow computer to key in the value displayed by the ammeter:</p> <ol style="list-style-type: none"> Select the Measured Output (mA)? field. Press OK. Enter the value. Press OK again or the Accept function key. 	
<p>15.</p>	<p>If needed, press the Abort function key to cancel the calibration.</p> <p>To continue to the Finalize Calibration screen, press the Apply HI function key.</p>	

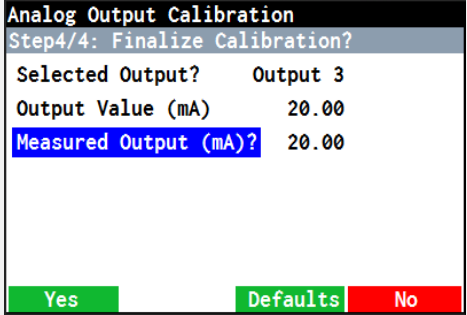
16.	<ol style="list-style-type: none"> a. If you have trouble calibrating the output channel, reset the channel by clicking the Defaults function key and attempt to calibrate the channel again. b. Press the Yes function key to finalize the calibration of the output channel. c. Press the No function key to discard the calibration changes. 	
17.	Continue calibrating additional output channels by repeating Steps 1 through 16.	

5.2 Calibrate Using OMNICONNECT™

The Calibration menu can be accessed through the **Diagnostics** button on the Home ribbon. If there is a project-specific requirement to reset all input and output channels before calibration, perform the steps in Section 7.1.2 Reset Multiple Channels before calibrating.



For inputs and outputs:

- Click the **Restore** button any time after starting a calibration. This command restores the calibration constants to the values they were when the calibration was initiated.
- Click the **Apply Defaults** button any time after starting a calibration to:
 - Reset the calibration constants to their default non-calibrated values.
 - Clear the adjustments for a selected channel.

5.2.1 Analog Inputs

To calibrate analog input channels that are configured in the flow computer, follow these instructions:

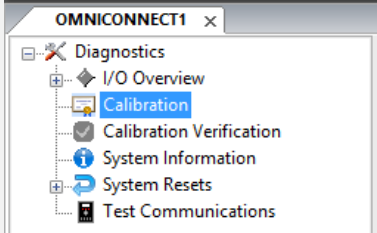
1.	Click the Diagnostics button in the Home ribbon to open the Diagnostics tree in the left panel.	
2.	Click Calibration in the left panel to display its configuration settings in the screens on the right.	

3. Select the **Analog Inputs** tab.



4. Select the input channel to calibrate from the drop-down list.

To include input channels in the drop-down list that were not assigned during configuration, check the **Include Unassigned I/O** box.

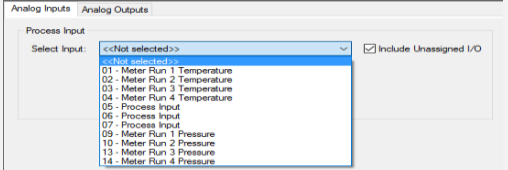

For a selected input channel with an active signal connected, the flow computer recognizes the live value and displays it in the **Live Value** field. If an I/O is assigned, the live value engineering units also display.

5. Verify that the signal wiring on the back panel is correct.

6.

- Click **Start Calibration**.
- Click **Yes** to confirm on the pop-up window.

This action records the following information in the **Measurement Audit Trail Log**:

- Time, date and I/O index
- Input # 'n' calibration start (n = input channel number)
- User name, user ID and port used for the calibration

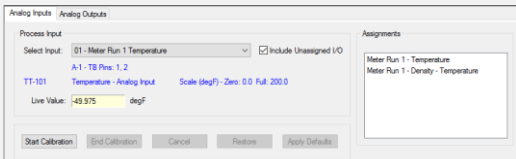

If the Remark field is not filled in during the Analog input channel configuration, then the Modbus register's database description, the hardware module and the Terminal Block pin numbers are still displayed in blue text after a selection is made.

If the input channel is unassigned, only the hardware module and Terminal Block pin numbers are still displayed in blue text.

7. If you are calibrating an input that has been assigned the **Set Override** box will appear and you shall be able to enter the override value:
- Verify or edit the default value and then click **Apply Override**.
 - Go to Step 10.

If you are calibrating an input that has not been assigned, only the **Calibration Units** box will appear (the **Set Override** box will not appear).

Continue to Step 8 and then 9.

8. Select the type of signal (for which the channel has been configured with the hardware jumpers), and click **Apply Units**.

The unit options are:

- mA
- Volts
- Ohms (if the channel has been configured for an RTD type signal)
- Engineering units (if an I/O channel is assigned)

9. Click **Calibrate Input**.

Click **Abort** to abort the current calibration sequence.

10. To apply the low calibration value in the **Calibration Values** screen:
- Adjust the **Signal Generator** or configure the **Transmitter**, whichever is connected, to output the lowest value needed to calibrate.
 - Wait 20 to 30 seconds for the readings to stabilize.
 - Enter an equivalent value in the appropriate units into the **Low Calibration Value** field (for example, 4 mA or 0.000 °F).
 - Click **Apply Low**.

Low values are 4.00 mA for a 4–20 mA input, 1V for a 1–5V input, and 25 ohms for an RTD input.

11. To apply the high calibration value in the **Calibration Values** screen:
- Adjust the **Signal Generator** or configure the **Transmitter** to output the highest value needed for calibration.
 - Wait 20 to 30 seconds for the readings to stabilize.
 - Enter an equivalent value in the appropriate units into the **High Calibration Value** (for example, 20 mA or 0.000 °F).
 - Click **Apply High**.

Calibration Values

Low Calibration Value: 4.000 mA

High Calibration Value: 20.000 mA

High values must be stated for each type of input: 20.00 mA for a 4–20 mA input, 5V for a 1–5V input, and 150 ohms for an RTD input.

12. To stop calibration, disconnect any signal simulators that are being used to calibrate the input channel, and reconnect the field instrument wiring according to your project-specific diagrams.

13. Click **End Calibration** to complete the calibration of the input channel. The calibration constants will be saved.

Click **Cancel** at any time to end the calibration without saving the calibration constants.

Analog Inputs Analog Outputs

Process Input

Select Input: 01 - Meter Run 1 Temperature Include Unassigned I/O

A-1 - TB Pins: 1, 2

TT-101 Temperature - Analog Input Scale (degF) - Zero: 0.0 Full: 200.0

Live Value: 200.000 degF Calibration Override: 49.975 degF

14. Continue calibrating additional analog inputs by repeating Steps 1 through 13.

15. If you have trouble calibrating the input channel, reset the channel and attempt to calibrate the channel again.
Go to Section 7.1 for troubleshooting.

5.2.2 Analog Outputs

To calibrate analog output channels that are configured in the flow computer, follow these instructions:

1. On the **Calibrations** screen, select the **Analog Outputs** tab.

Select the 4–20 mA output channel to calibrate from the drop-down list.

To include output channels in the drop-down list that have not been assigned in the configuration, check the **Include Unassigned I/O** box.

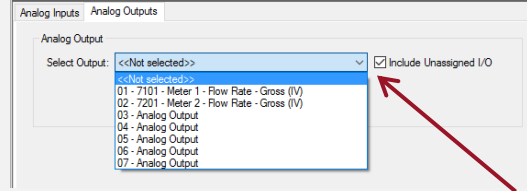

2. If the channel has been assigned in the configuration, confirm that the Modbus Register Assignment, Remark and Values at 4 mA and 20 mA are displayed in blue text.

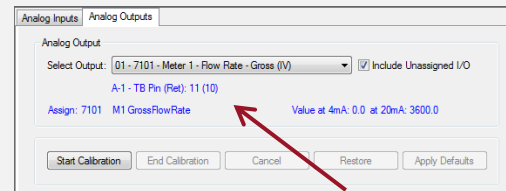

If the Remark field is not filled in during the Analog output channel configuration, then the Modbus register's database description, the hardware module and the Terminal Block pin numbers are still displayed in blue text after a selection is made. If the output channel is unassigned, only the hardware module and Terminal Block pin numbers are still displayed in blue text.

3. Connect an ammeter to the **Terminal Block** output pins in series between the flow computer and the external 4–20 mA device.

4. Click **Start Calibration**.

This action records the following information in the **Measurement Audit Trail Log**:

- Time, date and output index
- Output # 'n' calibration start (n = output channel number)
- User name, user ID and port hosting the calibration

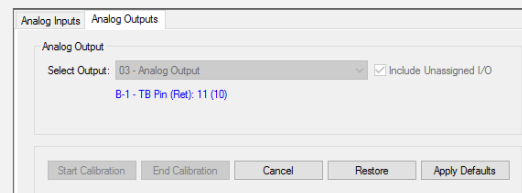

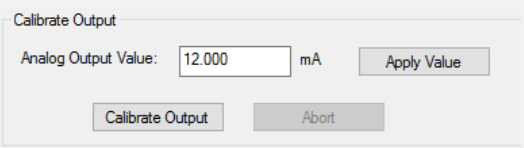
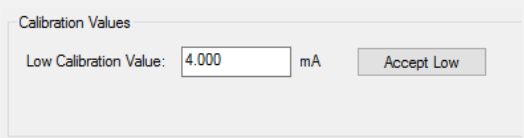
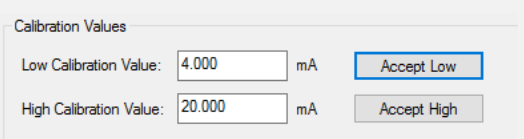
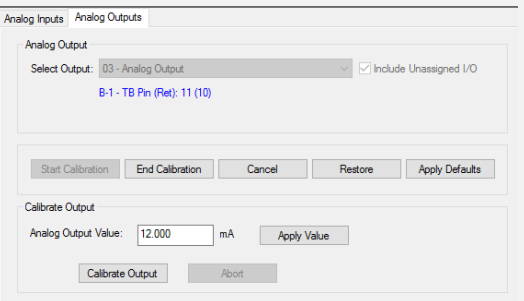
<p>5.</p>	<p>If needed, enter a value in milliamps in the Analog Output Value field, and click Apply Value.</p> <p>The flow computer will output the value using the current calibration constants.</p>	
<p>6.</p>	<p>Click Calibrate Output. If needed, click Abort to abort the current calibration sequence.</p> <p>The flow computer is instructed to output 4 mA.</p>	
<p>7.</p>	<p>Wait 20 to 30 seconds for the readings to stabilize.</p>	
<p>8.</p>	<p>Enter the value displayed on the ammeter; then click Accept Low.</p> <p>If the low value is accepted, the flow computer is instructed to output 20 mA.</p>	
<p>9.</p>	<p>Wait 20 to 30 seconds for the readings to stabilize.</p>	
<p>10.</p>	<p>Enter the value displayed on the ammeter; then click Accept High.</p>	
<p>11.</p>	<p>Click End Calibration to complete the calibration and save the calibration constants.</p> <p>Click Cancel at any time to end the calibration without saving the calibration constants.</p>	
<p>12.</p>	<p>Continue calibrating additional analog outputs as needed by repeating this section.</p>	
<p>13.</p>	<p>If you have trouble calibrating the input channel, reset the channel and attempt to calibrate the channel again.</p> <p>Go to Section 7.1 for troubleshooting.</p>	

6. Acceptance Testing Guidelines

Acceptance testing confirms that the hardware and software configurations of the OMNI flow computer system and field instruments are functioning according to project specifications. The test validates process variable inputs through output reporting.

The Factory Acceptance Test (FAT):

- Includes functional testing of all hardware components and software in the flow computer.
- Checks the functionality of components before they arrive at the installation site. These checks may include:
 - The power connection to verify that it supports project requirements.
 - The system wiring to instruments (or to the terminal block if a marshalling panel is used) to verify that the instruments receive and send signals.
 - Instrument connections by using simulators or overrides for transducer output signals.
 - I/O points by performing calibrations.

The Site Acceptance Test (SAT) verifies that the OMNI 4000/7000 measurement system values meet project specifications. This includes the tests performed during the FAT. SATs are performed on site and after installation, and they use live process variables and flowing product.

The SAT:

- Includes the following function tests:
 - Pressures, temperatures and flows.
 - Densitometers.
 - Provers.
 - Samplers.
- Validates hourly data and reports, such as daily, batch, proves, alarm and audit trail.
- Requires raw data from the flow computer to a DCS or SCADA for specific point-to-point testing requirements.

Each project must have a formal, project-specific FAT or SAT procedure. The guidelines in this section provide an overview of items to consider when you perform acceptance testing that includes an OMNI 4000/7000 flow computer.

6.1 Acceptance Testing Participants

Participants of the acceptance testing should consist of a combined team of the Integrator, the Buyer, the Seller and the Original Equipment Manufacturer (OEM) Representatives, including:

- The representative engineering company that is responsible for the system specification, hardware integration and configuration of the flow computer.
- Site-specific personnel from Operations, Regulatory and Quality Assurance.
- Support personnel from the OEM Vendor; Instrumentation; and Electrical, Communications and Safety.

6.2 Acceptance Test Procedure

An acceptance test procedure should include, as a minimum:

- A general description of the procedure based on system specifications.
- The clearly defined purpose, scope and objectives of the test to meet system requirements.
- A schedule showing the daily activities during the acceptance test.
- A section documenting the personnel who were present during the test or who conducted the testing.
- A list of the test equipment and instruments required to conduct the test.
- Detailed instructions to follow during the test, including a process data map for the FAT.
- A method to document the hardware identifiers (model number, serial number) and the revision level of the software and firmware to be tested.

Go to the checklist in Section 6.6 Acceptance Test Procedure Checklist for guidance when developing an acceptance test procedure.

6.3 Acceptance Test Tools

Table 6-1 lists tools and their function commonly used during acceptance tests. Incorporate these tools for a FAT or SAT, as needed.

Table 6-1: Acceptance Test Tools

Tool	Function
OMNICONNECT	Operates the flow computer and adjusts configuration.
Calibration Meter	Sends process input signals to simulate alarm conditions.
Function Generator	Drives frequency pulses that simulate flow.
Current System Specifications	Provides reference documentation and drawings.
FAT/SAT Procedures	Provides step-by-step requirements for testing.

6.4 Prepare for Acceptance Testing

Follow these guidelines to prepare for acceptance testing:

- Personnel meet all site-specific safety requirements.
- A minimum of two hardcopy sets of the acceptance testing procedure are on site.
- The associated drawings are current and readily available.
- A laptop with a fully licensed, latest version of OMNICONNECT is on site.
- The site has met the following requirements and is ready for testing:
 - A power source is available, and its voltage matches the equipment requirements.
 - Utilities are available, if needed (water, compressed air, steam, etc.)
 - Communications devices, such as an Ethernet or internet connections, phone lines and radio links are available, if needed.
 - Tools are calibrated according to specifications.
- A mechanical inspection of the cabinet, rack or enclosure that houses the flow computer has been performed, and it matches the design documentation.

- When possible, pictures of cabinets, doors and other items have been taken to record that the cabinet is in a good mechanical condition with no damage.
- A simulator to test pulse signals of flow transmitters to the OMNI flow computer is available for a FAT.

6.5 Post Acceptance Testing

6.5.1 Acceptance Testing Action Items

Documentation of procedures and results is a key component to accomplishing the test's intended purpose. One method of verifying that all findings and further required actions are documented is to maintain a punch list for logging any errors and action items found during the test. Table 6-2 is an example of a blank punch list and log to track the completion of action items.

Table 6-2: Action Item Log

No.	Description	Action By

6.5.2 Records

You should keep hardcopy and electronic copies of all acceptance testing records. These copies may include:

- A record of the test performed and the results, such as the actual values or pass/fail results.
- At least one set of hardcopy procedures and drawings signed by all personnel involved in the testing.
- A configuration report with 'as found' and 'as left' revisions.
- Reports generated by the flow computer.

Make sure that these records are incorporated in the engineering handover support package for operations.

6.6 Acceptance Test Procedure Checklist

Use the Acceptance Test Procedure Checklist as a guide for developing an acceptance test procedure. Check the box if an item applies to your factory or site acceptance test. This checklist provides some common actions and items required during flow computer acceptance testing:

- Confirm project-specific documentation is on-site and available.
- Perform a visual inspection of equipment:
 - Confirm that the flow computer has no mechanical damages (scratches, dents, etc.).
 - The serial numbers of the flow computer and modules match the numbers in the in-house report.
 - The instrument and communication cable is wired to the back panel according to project diagrams.
- Verify that the tools needed for the test are onsite:
 - The laptop for the test includes a fully licensed and current version of OMNICONNECT.
 - Equipment needed for the test is onsite and calibrated (Table 6-1).
- Apply power to the flow computer:
 - Verify that the front panel screen turns on and the diagnostic LEDs are lit.
 - Test the functionality of the front panel navigation keys.
- Establish communications with OMNICONNECT.
- Review the configuration to confirm that it matches project-specific requirements.
- Download and save an 'as found' configuration report.
- Apply live signals to process variables and perform an input/output calibration
- Compare the analog input to the output results:
 - Volumetric flow rates
 - Temperatures, pressures and density
- Confirm that the measurement algorithm table is correct:
 - The output results meet the applied standard.
 - Record any discrepancies.
- Function test alarms:
 - Test process alarms by actuating at set limits.
 - Clear and reset.
- Verify that the active alarms are captured and clear, as expected.
- Ready the flow computer for final commissioning.
 - Download and save an 'as left' report.
 - Reset RAM to clear all totalizers.
 - Reapply the 'as left' configuration.



For FAT testing, in lieu of live product, simulate inputs for flow, temperature, pressure and density.

7. Troubleshooting

7.1 Calibration

7.1.1 Reset Individual Channels

To reset the channel if you have trouble calibrating an individual analog input or output channel, follow these instructions:

1. Click the **Diagnostics** button in the Home ribbon to open the **Diagnostics** tree in the left panel.

Select **System Resets** in the left panel and then select the **Reset Calibration** tab in the screens to the right.

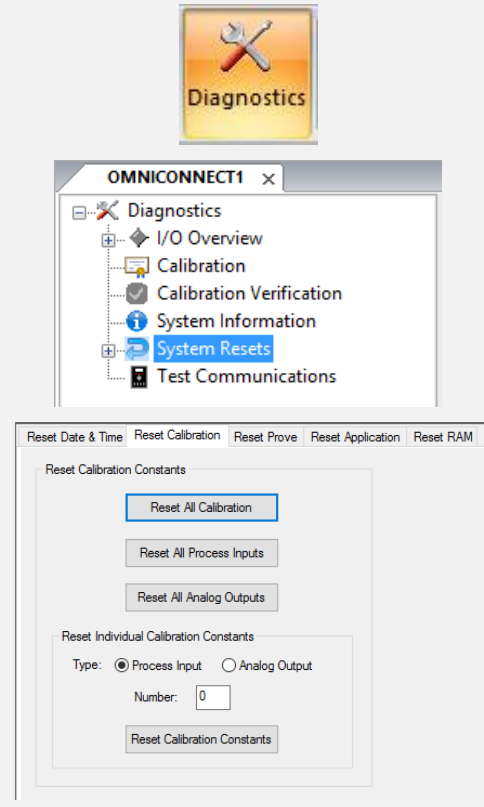

2. In the **Reset Individual Calibration Constants** section of the **Reset Calibration** screen:
 - a. Select the **Type** radio button for the channel.
 - b. Input the channel number in the **Number** field.
 - c. Click **Reset Calibration Constants**.

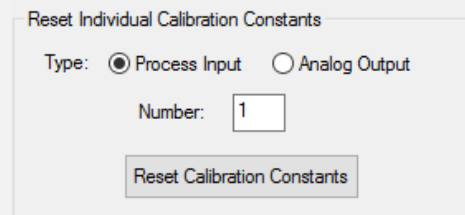

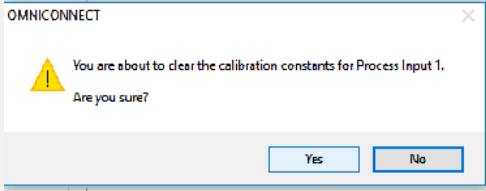
<p>3.</p>	<p>At the prompt, click Yes to reset the channel.</p>	
<p>4.</p>	<p>After you reset the channel, you can attempt to calibrate the channel again. You can do this either through the front panel (Section 5.1 Calibrate Using the Front Panel) or OMNICONNECT (Section 5.2 Calibrate Using OMNICONNECT™).</p>	
<p>5.</p>	<p>If the problem persists:</p> <ol style="list-style-type: none"> Check the hardware jumper settings for the channel in question. Check the software configuration settings to verify that they are set to the same type of input or output as the hardware jumpers. Contact the OMNI Help Desk at helpdesk@omniflow.com or call 281-240-6161. 	

7.1.2 Reset Multiple Channels

Use the option to reset multiple channels when:

- Project-specific requirements necessitate resetting all channels before beginning calibration.
- Multiple input or output channels will not calibrate correctly.

To reset multiple channels simultaneously, follow these instructions:

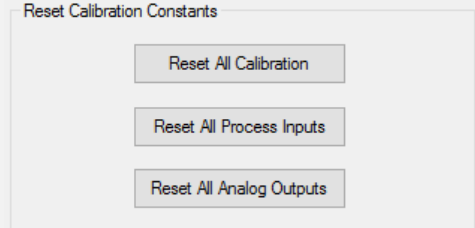
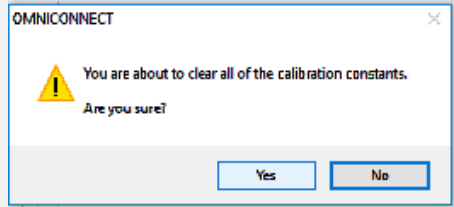
<p>1.</p>	<p>For multiple calibration resets, click the appropriate button:</p> <ul style="list-style-type: none"> • Reset All Calibration for resetting all Inputs and Outputs • Reset All Process Inputs for resetting analog inputs only • Reset All Analog Outputs for resetting analog outputs only 	
<p>2.</p>	<p>At the prompt, click Yes to reset multiple channels.</p>	

3. After you reset the channels, you can attempt to calibrate them again. You can do this either through the front panel (Section 5.1) or OMNICONNECT (Section 5.2).
4. If the problem persists:
 - a. Check the hardware jumper settings for the channel in question.
 - b. Check the software configuration settings to verify that they are set to the same type of input or output as the hardware jumpers.
 - c. Contact the OMNI Help Desk at helpdesk@omniflow.com or call 281-240-6161.

7.2 Troubleshooting Tables

7.2.1 Hardware



A flashing heartbeat on any module means that the onboard processor is functioning. This is a good indication that a problem may be elsewhere.

The system view for the flow computer includes the power distribution that starts with the proper power source being applied to the back panel terminal, distributed through the ribbon cables to the power supply unit (PSU), and then through the back plane mother board to the individual cards. Trouble shooting power issues is a process elimination through observation.

System Power			
Abnormal	Normal	Possible Causes	Suggested Action
<p>Front panel display and status indicators are OFF</p> <p>Heartbeat is not illuminated</p>	<p>Front panel:</p> <ul style="list-style-type: none"> • Display and status indicators are ON • Heartbeat flashing green (D55) 	<p>AC or DC power source malfunctioned</p>	<ul style="list-style-type: none"> • Check the PSU green LED is illuminated (DC power). If not, proceed to the next row of this table, PSU green LED, +24 V (D6) and +5 V (D7) illuminated (AC powered). • Check communications and digital modules, which may be illuminated by external circuits. • Check the CPU heartbeat and Digital Mux (if a part of the system) heartbeats. • Check AC and DC fuses. • Check ribbon cables A (and ribbon cable B for the 7000) and the AC power cable to the PSU for: <ul style="list-style-type: none"> – Proper connection – No bent pins – Proper orientation especially on the NEMA optioning option <p>(The connections are labeled and keyed)</p> <ul style="list-style-type: none"> • Replace with a spare power supply to test.

System Power			
Abnormal	Normal	Possible Causes	Suggested Action
PSU green LED not illuminated	PSU green LED, +24 V (D6) and +5 V (D7) illuminated (AC powered)	Power, fuse, or line problem	<ul style="list-style-type: none"> Try DC power, if available, to determine if the AC power source malfunctioned. If the flow computer does not power on, replace the PSU.
		Faulty field wiring is loading down the system	<ul style="list-style-type: none"> Remove All I/O and communication cards. With just the front panel, CPU, and PSU connected, reapply power. If the flow computer powers on, then power the unit off and inspect and install each I/O board one at a time. If the flow computer does not power on, replace the PSU.
Flow Computer will not power on AC	For unit powered by 24 VDC, the large green LED is off (DC powered)	Power, fuse, or line problem	<ul style="list-style-type: none"> Use a spare power supply for troubleshooting. If the flow computer does not power on, check the fuses and lines.
		Faulty field wiring is loading down the system	<ul style="list-style-type: none"> Remove All I/O and communication cards. With just the front panel, CPU, and PSU connected, reapply power. If the flow computer powers on, then power the unit off and inspect and install each I/O board one at a time. If the flow computer does not power on, replace the PSU.

Front Panel			
Abnormal	Normal	Possible Causes	Suggested Action
No display	The display is showing system data and menus	<p>Power source malfunction</p> <p>An overcurrent condition overloaded a fuse, tripping it</p> <p>A front panel ribbon cable malfunction</p>	<ul style="list-style-type: none"> • Check the heartbeat. • Check that the front panel keys beep when pressed. • Check the system power. • Use OMNIPANEL to verify the flow computer is functioning properly. • If there is normal front panel functionality through OMNIPANEL, check the front panel ribbon cable: <ul style="list-style-type: none"> – Inspect for damage to cable and no bent pins. – Verify the cable is installed with the correct orientation
No key press beeps	Keypress functions for screen navigation includes a beep with each key press	Front panel is faulty	<ul style="list-style-type: none"> • Replace the front panel with a spare to test.

CPU			
Abnormal	Normal	Possible Causes	Suggested Action
Battery voltage LED indicator illuminated red	Battery voltage indicator illuminated green	<p>Power not applied</p> <p>LED burned out</p> <p>Coin cell battery needs replace</p>	<ul style="list-style-type: none"> • Verify that the flow computer is powered on. • Test the front panel. If there is a response, the LED is burned out. Replace the CPU card (optional). • Replace the cell battery

CPU			
Abnormal	Normal	Possible Causes	Suggested Action
Heartbeat light not illuminated	Blue flashing heartbeat steady one beat per second	Power not applied	<ul style="list-style-type: none"> • Check status LED's function. • Verify the flow computer is powered on. • Test the front panel: <ul style="list-style-type: none"> – If there is a response, the LED is burned out. Replace the CPU card (optional). – If there is no response, the CPU is not working. Replace the CPU.
Solid blue heartbeat		LED burned out	
Three quick flashes of the heartbeat LED, then a pause		CPU malfunctioned	
		Bootloader and firmware are not running	<ul style="list-style-type: none"> • Check the front panel display. • If there is an issue with the loaded firmware, then the firmware will need flashed to correct the issue.
		Status light indicates that the CPU is in Boot Loader mode waiting for firmware to be uploaded	<ul style="list-style-type: none"> • Check the front panel for the Bootloader screen. • Using OMNICONNECT or the SmartFlash utility: <ul style="list-style-type: none"> – Establish a serial connection to the onboard USB of the CPU. – Upload the firmware. • If the flash process fails, replace the CPU with a spare.
Solid blue heartbeat light with no Front panel display	Front panel display and key press all function normally	Faulty CPU	<ul style="list-style-type: none"> • Power off, remove all other modules except the PSU, front panel, and CPU. • Power back up. If problem persists, replace the CPU with a spare. • Try installing the CPU in a spare flow computer to confirm that the CPU is faulty

SD Module			
Abnormal	Normal	Possible Causes	Suggested Action
LED not illuminated	Green solid LED Green SD card indicator is enable and configured Green blinking LED when reading or writing a record	The SD module is not present The SD module is present but not enabled The SD module is not formatted for use	<ul style="list-style-type: none"> • Check if the status indicates one of the following: <ul style="list-style-type: none"> – No Card – Not Enabled – Not Formatted • Insert and enable an SD card. • If the status does not read “Ready” on the front panel, format the SD card from the front panel.
Amber solid LED The SD card status indicates “Read Only” or “No Sys File!” on the front panel		The SD module is set to the locked position or was removed and the system files manually deleted before it was reinserted into the Omni CPU	<ul style="list-style-type: none"> • With the SD card inserted: <ul style="list-style-type: none"> – Follow the proper eject procedure from the front panel. – Remove the SD card and ensure it is set to the unlocked position. – Reinsert the SD card and follow the Enable procedure from the front panel. • It may be necessary to format the card for it to show the status as ‘Ready’.
Red solid LED		The eject procedure from the front panel was not followed before physically removing the SD card.	<ul style="list-style-type: none"> • Check if the Status indicates “Improper Eject”. • Physically reinsert the SD card, execute the eject procedure from the front panel, then use the Enable procedure. • Format the card if the Status does not indicate as “Ready”.

Digital I/O Multiplexer			
Abnormal	Normal	Possible Causes	Suggested Action
Heartbeat light is steady illuminated	Heartbeat light flashing blue (DS1)	The firmware for the DM module is not running or corrupted	Replace DM Module with a spare.
Heartbeat light is not illuminated		DM module is not powered	<ul style="list-style-type: none"> • Check the system power. • Verify that the flow computer is powered on. • If problem persist, replace DM Module with a spare.
If an external DT module is in use and no activity on the CAN STATUS LEDs	Activity will be shown on the CAN STATUS LEDs	DT module communication link not connected correctly	<ul style="list-style-type: none"> • Verify wiring is connected according to the project specific drawings • Verify that the DT Module is powered, operating, and the heartbeat LED is flashing
Red status LED on the active I/O point	Status indicators for each 10 I/O points may be on, off, or flashing.	An overcurrent condition overloaded the fuse, tripping it	<ul style="list-style-type: none"> • Remove condition that is causing the overload. The fuse will automatically reset. • Remove the wire associated with the point. <ul style="list-style-type: none"> – The PTC over current protection for the I/O point will reset. – Verify that the LED is green. • Review the circuit associated with the I/O point. • If the red LED does not clear after removing the wire, then reset the system. • If problem persist, replace DM Module with a spare.

Digital I/O Terminal Board			
Abnormal	Normal	Possible Causes	Suggested Action
No activity on the CAN STATUS LEDs	Flashes red Flashes green	Transmitting data to the DM(s) TX. Receiving data from the DM(s) RX.	<ul style="list-style-type: none"> Verify wiring is connected according to the project specific drawings Verify that the DT Module is powered, operating, and the heartbeat LED is flashing If problem persists, replace DT Module with a spare.
Red active I/O point	Green active I/O point	An overcurrent condition overloaded the fuse, tripping it.	<ul style="list-style-type: none"> Remove the condition causing the overload. Remove and reconnect the wire on the digital channel.

Digital I/O Multiplexer (edge) and Digital Terminal Board (middle)			
Abnormal	Normal	Possible Causes	Suggested Action
Red active I/O point	Green active I/O point	An overcurrent condition overloaded the fuse, tripping it	Remove the condition causing the overload. The fuse will automatically reset.

7.2.2 Alarms

CPU Alarms		
Alarm Message	Possible Causes	Suggested Action
Flash Jumper is Enabled	The jumper that allows the CPU firmware to be updated is in the Enable position.	Move jumper to position Disable .
Battery voltage	Possible Causes	Suggested Action
CPU Battery Fault	Low battery voltage.	Replace the battery.

Flow Alarms		
Alarm Message	Possible Causes	Suggested Action
No Gross Flow Rate	The flow signal is not reaching the flow computer or missing K-factor.	<ul style="list-style-type: none"> Ensure the flow signal is reaching the flow computer.
	The K-factor linearization values are not properly configured.	<ul style="list-style-type: none"> Under Meter, check whether the K-Factor value was configured. Under Meter, check whether the K-factor curve was properly configured.
No Net Flow Rate	Density signal not reaching the flow computer	<ul style="list-style-type: none"> Ensure the density signal is reaching the flow computer.
	A missing configuration for live Density, or Reference Density.	<ul style="list-style-type: none"> Under Meter Density and Product, check whether the meter density is properly configured.
No Mass Flow Rate	Density signal not reaching the flow computer	<ul style="list-style-type: none"> Under Product, ensure the Density Override is properly configured.
	A missing configuration for live Density, or Reference Density.	<ul style="list-style-type: none"> Under Meter Density, ensure the live density source is properly configured.

Measurement Algorithm Alarms		
Symptom	Possible Causes	Suggested Action
M(X) API 11.1 Temp. Invalid	The temperature value on the Meter Run is outside the allowable limits for the selected measurement algorithm.	<ul style="list-style-type: none"> • Check the temperature value from the transmitter. • Check any override value in use. • Check whether the signal scaling for the temperature transmitter is properly configured.
M(X) API 11.1 Pressure Invalid	The pressure value on the Meter Run is outside the allowable limits for the selected measurement algorithm.	<ul style="list-style-type: none"> • Check the pressure value from the transmitter. • Check any override value in use. • Check whether the signal scaling for the pressure transmitter is properly configured.
M(X) API 11.1 Density Invalid	The density value on the Meter Run s outside the allowable limits for the selected measurement algorithm.	<ul style="list-style-type: none"> • Check the density value from the transmitter. • Check any override value in use. • Check whether the signal scaling and factory entered coefficients for the density transmitter are properly configured in the flow computer.

8. Technical Specifications

In accordance with a policy of product development and improvement, OMNI Flow Computers, Inc. may make any necessary changes to these specifications without notice.

Panel Mount	Dimensions	
	OMNI 4000	OMNI 7000
Front Panel Cut-Out	8.25 x 4.75 inches (210 x 121 mm)	
Behind Panel	9.50 inches (241 mm)	16.25 inches (413 mm)
Front Panel Bezel	9.25 x 5 inches (235 x 127 mm)	
Weight	10.5 lbs. (4.8 kg)	17.5 lbs. (7.9 kg)

Panel Mount (Extended Back Panel)	Dimensions	
	OMNI 4000	OMNI 7000
Front Panel Cut-Out	8.25 x 4.75 inches (210 x 121 mm)	
Behind Panel	8.75 inches (222 mm)	15.50 inches (394 mm)
Front Panel Bezel	9.25 x 5 inches (235 x 127 mm)	
Extended Back Panel	8.75 inches (222 mm)	18.50 x 3.5 inches (470 x 89 mm)
Weight	10.5 lbs. (4.8 kg)	19.0 lbs. (8.6 kg)

NEMA option	Dimensions	
	OMNI 4000	OMNI 7000
Front Panel Cut-Out	6.78 x 1.65 inches (172 x 42 mm)	
Chassis	8 x 6.75 inches (216 x 172 mm)	8 x 13.5 inches (216 x 343 mm)
Front Panel Bezel	9.25 x 5 inches (235 x 127 mm)	
Extended Back Panel	8 x 4.5 inches (203 x 114 mm)	18.5 x 3.5 inches (470 x 89 mm)
Weight	7.75 lbs. (3.5 kg)	13 lbs.(5.9 kg)

NEMA 4X Enclosure	Dimensions	
	Single Flow Computer	Dual Flow Computer
Enclosure	23.6 x 23.6 x 11.8 inches (600 x 600 x 300 mm)	
Weight	87 lbs. (39.4 kg)	100 lbs. (45.3 kg)

Environmental	Operating Parameters
Operating Temperature	+14 °F to +140 °F (-10 °C to +60 °C)
Storage Temperature	-4 °F to +158 °F (-20 °C to +70 °C)
Relative Humidity	90% non-condensing maximum
Mechanical	Class M3 (high levels of vibration) as defined in OIML R117-1:2007
Electrical	Class E2 (heavy industrial environments) as defined in OIML R117-1:2007

Electrical	Specifications
Supply Voltage for Power Supply Module Model 68-6218	<ul style="list-style-type: none"> 90 to 264 VAC, 47 to 440 Hz or 22 to 26 VDC 10 to 22 W (excluding transducer loops) 10 to 35 W (including transducer loops) <p>Caution: Maximum DC offset from +DC or -DC to Earth Ground is 120 VDC.</p>
Transducer Output Power	24 VDC at approximately 350 mA for most configurations (when AC powered)
Isolation	<ul style="list-style-type: none"> All analog inputs and outputs are electrically isolated from computer logic supply. Maximum common mode voltage on any input or output is ± 250 VDC to chassis ground.
Power Fuse	<ul style="list-style-type: none"> Located on Standard/Extended Back Panels Standard Back Panel (4000/7000) <ul style="list-style-type: none"> DC Fuse 5x20 = 3.15 A Slow Blow (Littelfuse #02183.15) AC Fuse 5x20 = 1.6 A Fast Blow (Littelfuse #021701.6) Extended Back Panel (7000) <ul style="list-style-type: none"> DC Fuse 2AG = 3 A Slow Blow (Littelfuse #0229003) DC Fuse for Transducer Loop power 2AG = 250 mA Fast Blow (Littelfuse #0225.250) AC Fuse 5x20 = 1.6 A Fast Blow (Littelfuse #021701.6)
Transient/Over-voltage Protection for Power Supply Module Model 68-6218	Current limiting circuit and Transzorbs

CPU Microprocessor and Memory		Specifications
Type	<ul style="list-style-type: none"> • 32-bit microprocessor • Clock speed: 416.67 MHz maximum • Hardware floating point • ECC error correcting memory • Hardware encryption • Secure digital card interface 	
Flash	16 MB	
RAM	128 MB SDRAM (DDR2)	
Nonvolatile RAM	<ul style="list-style-type: none"> • 4 MB (no battery required) • Stores configuration data and historical records • Saves 35 most recent daily and batch records • 1 MB reserved for user archives 	
SD Card	8 GB available for storing historical records	
Real Time Clock	<ul style="list-style-type: none"> • Maintains time during power loss • Reports downtime on power-up • Field replaceable battery • Battery monitor and alarming 	
Real Time Clock Battery Backup Period	<ul style="list-style-type: none"> • 1000 days (2.75 years) typical • Actual backup period: <ul style="list-style-type: none"> – Dependent on ambient temperature of the equipment – Higher ambient temperatures increase the self-discharge rate of the battery 	
USB Device Port	<ul style="list-style-type: none"> • Mini-B receptacle • Provides interface for CPU Firmware updates • Compatible with a USB 2.0 full speed transfer rate 	

Motherboard		Specifications
Type	Proprietary configured with plug-in DIN connectors for CPU, PSU and I/O Modules	
Transient Protection	Transzorb devices on motherboard	
Number of I/O Module Slots	OMNI 4000	OMNI 7000
	4 slots	10 slots

Process Input and Output Modules Capabilities and Features							
Type	Input #1	Input #2	Input #3	Input #4	Analog Outputs	Level A Fidelity	Double Chronometry Proving
A	4-20 mA, 1-5 V, RTD		4-20 mA, 1-5V, Flow Pulses		Two 4-20 mA	No	No
B	4-20 mA, 1-5 V, RTD		4-20 mA, 1-5V, Flow Pulse	Frequency Density	One 4-20 mA	No	No
E/D	4-20 mA, 1-5 V, RTD		Frequency Density		Two 4-20 mA	No	No
E	4-20 mA, 1-5 V, RTD		Flow Pulses		Two 4-20 mA	Yes	Yes
HT/HM	HART FSK Protocol				Two 4-20 mA	No	No

Flowmeter Pulse Inputs*	Specifications
Input Frequency	<ul style="list-style-type: none"> DC to 15 kHz square wave DC to 12 kHz sine wave**
Positive Going Trigger Threshold	+4.2 V ± 0.2 V (nominal @ 1 kHz)
Negative Going Trigger Threshold	+3.2 V ± 0.2 V (nominal @ 1 kHz)
Input Impedance	1 MΩ (nominal @ 1kHz)
Configuration	Differential input (E module inputs are single-ended referenced to DC return)
Common Mode Voltage	±250 VDC to chassis ground
Pulse Fidelity Check	Channels are continuously compared for frequency and sequence
E Module Only	<ul style="list-style-type: none"> Complete failure of either A or B channel will not affect totaling Simultaneous noise pulses are rejected with better than 90% certainty

* Use the DC coupling–high threshold setting.

** The maximum frequency allowed is reduced when operating with a sine wave input signal. This is because the signal must extend beyond the high-level threshold and below the low-level threshold for a minimum of 30µs to allow the photo-optical couplers to conduct.

Densitometer Pulse Inputs*	Specifications
Positive Going Trigger Threshold	<ul style="list-style-type: none"> +1.6 V \pm 0.2 V–AC coupling: low threshold +4.2 V \pm 0.2 V–DC coupling: high threshold
Negative Going Trigger Threshold	<ul style="list-style-type: none"> +1.2 V \pm 0.2 V–AC coupling: low threshold +3.2 V \pm 0.2 V–DC coupling: high threshold
Minimum Signal Level	2 V peak to peak
Maximum Signal Level	5 V peak to peak
Minimum Frequency	100 Hz (10,000 μ s period)
Maximum Frequency	6.7 kHz (150 μ s period)

*Use AC coupling–low threshold or DC coupling–high threshold settings.



AC coupling is only used in conjunction with the low signal input threshold setting. It is available for densitometer periodic time measurements only.

Prover Detector Switch Inputs: Conventional and Pipe	Specifications
Input Type	Digital I/O
Gating Transition	Voltage transition starts and stops prove run counts
Minimum Time Pulse High	1 ms
Minimum Time Pulse Low	> 100 ms
Input Impedance	4.7 k Ω
Input Voltage	> +5 VDC ON, < +4 VDC OFF (referenced to DC return)
Debounce	100 ms in hardware logic
Common Mode Voltage	\pm 250 VDC to chassis ground

E Combo Module Prover Detector Switch Inputs: Pulse Interpolation	Specifications
Input Type	<ul style="list-style-type: none"> Digital I/O (active-low) Normally driven by a bounce-free open collector transistor or a normally open switch
Gating Transition	Voltage transition starts and stops prove run counts
Input Voltage	> +7 VDC ON, < +6 VDC OFF (referenced to DC return)

Analog Inputs	Specifications
Input Type	1-5 V or 4-20 mA
Input Impedance	<ul style="list-style-type: none"> 1 MΩ when configured for 1-5 V 250 Ω when configured for 4-20 mA (selected by installing shunt resistor)
Resolution	14 binary bits
Accuracy	$\pm 0.025\%$ of reading ± 2 counts 14 °F to 131 °F (-10 °C to +55 °C)
Common Mode Voltage	± 250 VDC to chassis ground

RTD Inputs	Specifications
RTD Configuration	4-wire bridge
RTD Resistance	100 Ω at 32 °F (0 °C)
Excitation Current	3.45 mA nominal (± 0.02 mA)
Maximum Field Wiring Resistance	1 k Ω per wire
Resolution	0.008 Ω
Range	-229 °F to 293 °F (-145 °C to +145 °C)
Accuracy	$\pm 0.025\%$ of reading ± 2 counts 14 °F to 131 °F (-10 °C to +55 °C)
Common Mode Voltage	± 250 VDC to chassis ground

Analog Outputs	Specifications
Resolution	12 binary bits
Output	Current source 4-20 mA (referenced to transducer power return terminal)
Common Mode	± 250 V to chassis ground
Maximum/Minimum Working Loop Voltage	30 to 18 VDC
Loop Resistance	<ul style="list-style-type: none"> 900 Ω with 24 VDC power 1.2k Ω with 30 VDC power
Update Rate	Each 500ms
Accuracy	$\pm 0.05\%$ of reading ± 2 counts 14 °F to 131 °F (-10 °C to +55 °C)

HART Module (HT/HM)	Specifications
Physical link	Frequency Shift Keying (FSK)
Networks*	4 per Module – 24 Max
Devices	<ul style="list-style-type: none"> 1 per Network – 24 Max (HT Module) 4 per Network – 96 Max (HM Module)
Loop Power	+24 VDC (+/- 0.25V) supplied from the 4/7000 Back Panel or external DC supply
Internal Load Resistance**	Selectable for each network (250 ohms, 500 ohms or Out)
LEDs	Indicators for each network (activity and status)
Minimum Input Threshold for Carrier Detect	120 mVpp
Baud Rate	1200 bps
Common Mode Voltage	±250 VDC to chassis ground
* 6 HT/HM modules maximum	
** If load resistance is set to “Out” position, an external load resistor from 250 – 600 ohms must be provided.	

Control Outputs/Status Inputs*	Specifications
Configuration	FET transistor source (referenced to DC return)
Configured as an Output	
Output Current Capacity	200 mA maximum per point, 500 mA maximum for the DM module
Output Voltage	+DC–1V nominal
Scan Rate	Outputs may be pulsed at 50 Hz maximum.
Configured as an Input	
Input Impedance	4.7 kΩ
Input Voltage	<ul style="list-style-type: none"> Input voltages > +5 VDC to < DC+ will be recognized as ON (referenced to DC return). Input voltages < +4 VDC will be recognized as OFF (referenced to DC return). 30 VDC Maximum
LEDs	Operating and fault condition indicators on each channel
Common Mode	±250 V to chassis ground
*10 Per DM module, one module per unit	

Multi-Bus Serial I/O Module*		Specifications
RS-232		
Serial Data Output Voltage	±7.5 V typical	
Recommended Load Impedance	1.5 kΩ	
Short Circuit Current	10 mA limited	
Input Low Threshold	-3.0 V	
Input High Threshold	+3.0 V	
Baud Rate	Software selectable range: .3, .6, 1.2, 2.4, 4.8, 9.6, 19.2, 38.4 kbps	
Common Mode Voltage	±250 VDC to chassis ground	
LEDs	Indicator LEDs for each channel input, output and handshaking signals	
RS-485		
Serial Data Output Voltage	5 V differential driver	
Recommended Load Impedance	120 Ω (located on module)	
Short Circuit Current	20 mA limited	
Differential Input Low Threshold	-0.2 V	
Differential Input High Threshold	+0.2 V	
Baud Rate	Software selectable range: .3, .6, 1.2, 2.4, 4.8, 9.6, 19.2, 38.4 kbps	
Common Mode Voltage	±250 VDC to chassis ground	
LEDs	Indicator LEDs for each channel input, output and handshaking signals	
*2 ports for each module. Each port can be configured for RS-232, RS-485 2-wire or 4-wire.		

Dual Ethernet Module		Specifications
Ethernet		
Physical	10/100 BaseT	
Speed	10/100 Mbits/s	
Ports	2 per module	
Connections	8 simultaneous per port; the default TCP port setting is 7001 through 7008	
Protocols	Modbus, Modbus/TCP, LPD, Syslog, Telnet, TCP, UDP SSL (individually enabled/disabled for each virtual connection)	

Dual Ethernet Module	Specifications
RS-485 2-WIRE	
Ports	2 per module
Serial Data Output Voltage	5 V differential driver
Recommended Load Impedance	120 Ω ; termination located on module through software selectable enable/disable
Short Circuit Current	120 mA maximum
Input Low Threshold	0.2 V
Input High Threshold	TBD
Baud Rate	Software selectable range: .3, .6, 1.2, 2.4, 4.8, 9.6, 19.2, 38.4 kbps
Common Mode Voltage	\pm 250 VDC to chassis ground
LEDs	Indicator LEDs for each channel input, output signals
Protocols	Modbus, Modbus/TCP, LPD

Operator Keypad	Specifications
Keypad Characteristics	25 keys with tactile and audio feedback: numeric, function, operational and navigation keys
Data Entry Lockout	Internal switch and software passwords
Key Debounce	Software controlled
USB Device Port	<ul style="list-style-type: none"> • Mini-B receptacle • Modbus compatible • 230400 baud rate, no parity, 8 data bits, 1 stop bit
USB Host Port	<ul style="list-style-type: none"> • Type-A receptacle • Provides interface to update CPU firmware using a USB memory stick

LCD Display	Specifications
Display	800 x 480 color graphics
Viewable Temperature	+14 °F to +140 °F (-10 °C to +60 °C)

Alarm Indicator LED	Specifications
Dual Color	Red/green
Indication	Active alarm LED: <ul style="list-style-type: none"> • Red indicates a new, unacknowledged alarm exists. • Green indicates an acknowledged alarm exists. • Not lit indicates that no alarms are present.

Security	Specifications
Hardware	Optional lock on housing and internal keyboard program lockout
Software	<ul style="list-style-type: none"> • Multi-user, multi-level password controls on OMNICONNECT, OMNIPANEL access • Port security for SCADA and HMI systems • SSL encryption on Ethernet connections • Front Panel User ID and PIN

Appendix A. Jumper Settings

A.1 Serial Module

Configure for RS-485 Mode

To access the serial module and configure the jumper blocks when an RS-485 setting is required, follow these instructions:

1. Verify that the power to the flow computer is **OFF**.
2. If you are using the panel mount chassis, lift the Front Panel Bezel upwards in order to slide the inner chassis out.
If you are using the NEMA chassis, remove the card-retaining bracket from the chassis.
3. Use the card ejector to remove the serial module from the chassis.
Make note of the serial module's designated slot number on the motherboard.
4. Locate the following port(s) and jumpers:
 - a. Port 1: JB4, JB5 and JB6
 - b. Port 2: JB1, JB2 and JB3
5. Apply one of the following RS-485 jumper settings (a, b, c, or d) according to project requirements.

For each configuration, the jumper needs to be in the on (closed) position.
 - a. Terminated RS-485 2-wire

Terminate the RS-485 devices at the ends of an RS-485 bus network.
 - b. Unterminated RS-485 2-wire

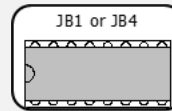

On (closed)

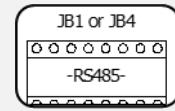

Off (open)

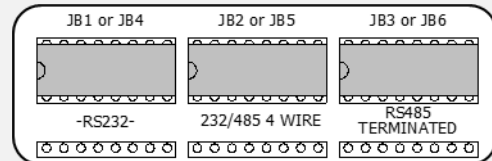
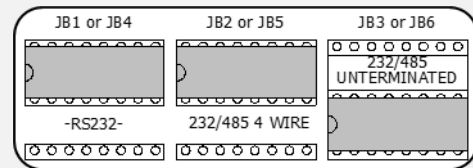

	<p>c. Terminated RS-485 4-wire</p> <p>d. Unterminated RS-485 4-wire</p>	
<p>6.</p>	<p>When positioning is complete, update your project drawings and documents. Go to Table 3-6 for guidance on back panel wiring.</p>	
<p>7.</p>	<p>Reinsert the Serial module into its designated slot.</p>	
<p>8.</p>	<p>To reinstall the panel mount chassis, slowly slide the inner chassis back into the flow computer.</p> <p>For the NEMA chassis, re-install the card-retaining bracket.</p>	

A.2 A/B Combo Module

The A/B Combo Module is configured for either an A module or a B module by positioning the module TYPE jumper (JPB) in either the A or B position.

Each A or B module requires a specific address of 1 through 6. Position the jumper's address (ADD) for A0, A1 and A2 as indicated in the jumper table located on the PCB.

The A module can have either:

- Two analog outputs (4-20mA) where the Analog Out #2 jumper must be installed for the second analog output.
- One analog output and two RTD excitation current sources.

When the jumper is installed in the RTD2 position, this second output then becomes the second RTD excitation current source (3.45 mA) and the second analog output is no longer available.

The B module has one analog output (4-20mA) and two RTD excitation sources (3.45 mA). The RTD2 jumper is always installed on a B combo.



To avoid using the second RTD excitation source and retain an analog output, use an available excitation source on another combo module.

Input Channels 1 and 2 can accept:

- Analog input voltages (1-5 VDC)
- Current inputs (4-20mA) converted to 1-5 VDC by installing the 4-20 jumper
- Low level RTD input signals (0.20–0.55 VDC)

Installing the RTD jumper increases the signal input by a factor of 10X.

Input Channels 3 and 4 can accept:

- Analog input voltages (1-5 VDC)
- Current inputs (4-20mA) converted to 1-5 VDC by installing the 4-20 jumper
- Pulse signals (0-12 KHz) by removing the four “A” jumpers and installing the two “P” jumpers

Input Channel 4 can be configured for AC or DC signal coupling. The input signal trigger threshold can be lowered from 3.5 to 1.5 VDC by removing the input threshold HI jumper, which makes it suitable for interfacing to Solartron type densitometers.

A.3 A/B Module Setup

Configure the A/B Combo as either an A module or a B module by positioning the TYPE jumper (JPB) as indicated in Figure A-1.

Assign a unique address to each A or B module installed into the OMNI flow computer by positioning the jumper’s address (ADD) in the jumper table as indicated in Figure A-1.

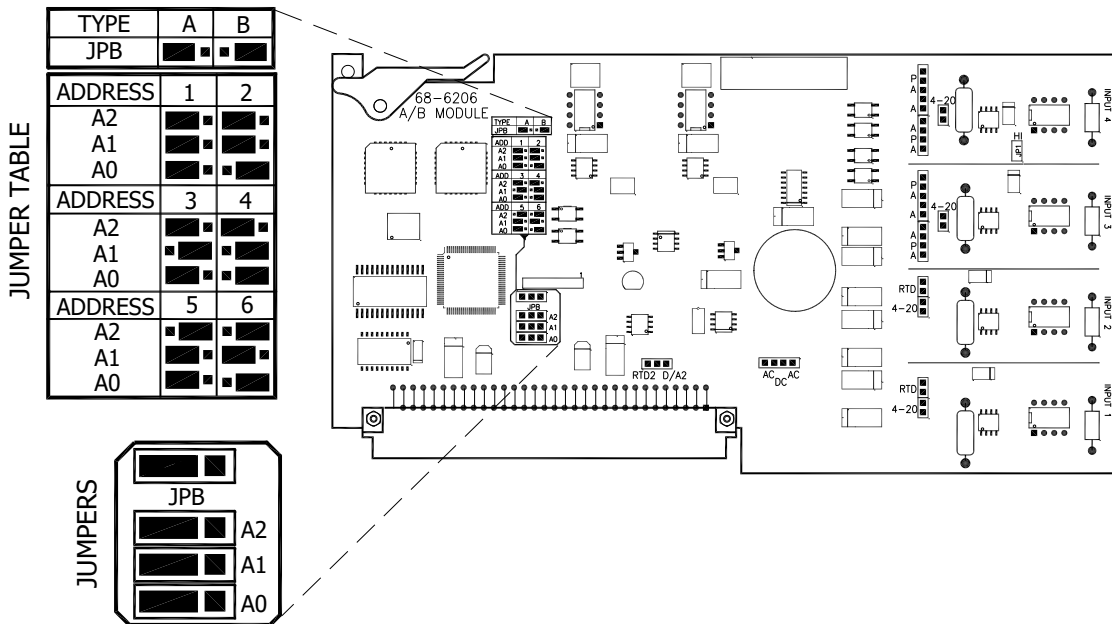

Figure A-1: A Module Type and Address Jumpers

A.3.1 A Module Process Input Type – Analog

To configure an A module for Analog Inputs, set the jumpers according to these instructions.

Configure Inputs 1 and 2 for one of three analog signal types:

- For 1-5 VDC Input, remove both RTD and 4-20 jumpers.
- For 4-20 mA Input, install the 4-20 jumper.
- For RTD Input, install the RTD jumper.

Configure Input 3 for one of the two analog signal types:

- Install all four “A” jumpers.
- For 1-5 VDC Input, remove the 4-20 jumper.
- For 4-20 mA Input, install the 4-20 jumper.

Configure Input 4 for one of the two analog signal types:

- Install all four “A” jumpers.
- Install the DC coupling jumper.
- Install the HI signal threshold.
- For 1-5 VDC Input, remove the 4-20 jumper.
- For 4-20 mA Input, install the 4-20 jumper.

Refer to Figure A-2 for default input and output jumper settings: Inputs Ch1 = 4-20mA, Ch2 = 4-20mA, Ch3 = 4-20mA, Ch4 = 4-20mA and Output Ch2 = 4-20mA.

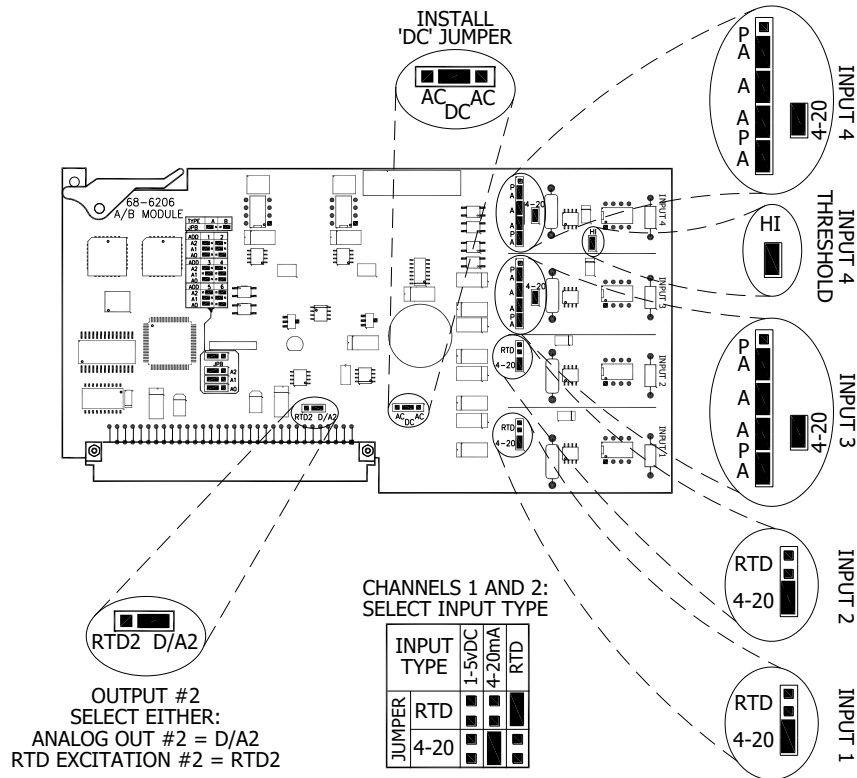

Figure A-2: A Module Analog Jumper Settings

A.3.2 A Module Process Input Type – Pulse

To configure an A module Pulse Inputs, set the jumpers according to these instructions.

Configure Inputs 1 and 2 for one of three analog signal types:

- For 1-5 VDC Input, remove both RTD and 4-20 jumpers.
- For 4-20 mA Input, install the 4-20 jumper.
- For RTD Input, install the RTD jumper.

Configure Input 3 for one of the three signal types:

- Analog Input:
 - Install all four “A” jumpers.
 - For 1-5 VDC Input, remove the 4-20 jumper.
 - For 4-20 mA Input, install the 4-20 jumper.
- Pulse Input:
 - Remove all four “A” jumpers, and install the two “P” jumpers.
 - Install the DC coupling jumper.

Configure Input 4 for pulse signal types:

- Remove all four “A” jumpers, and install the two “P” jumpers.
- Install the DC coupling jumper.
- Install the HI signal threshold.
- Remove the 4-20 jumper.

Refer to Figure A-3 for default input and output jumper settings: Inputs Ch1 = 4-20mA, Ch2 = 4-20mA, Ch3 = Pulse, Ch4 = DC coupled Pulse and Output Ch2 = 4-20mA.

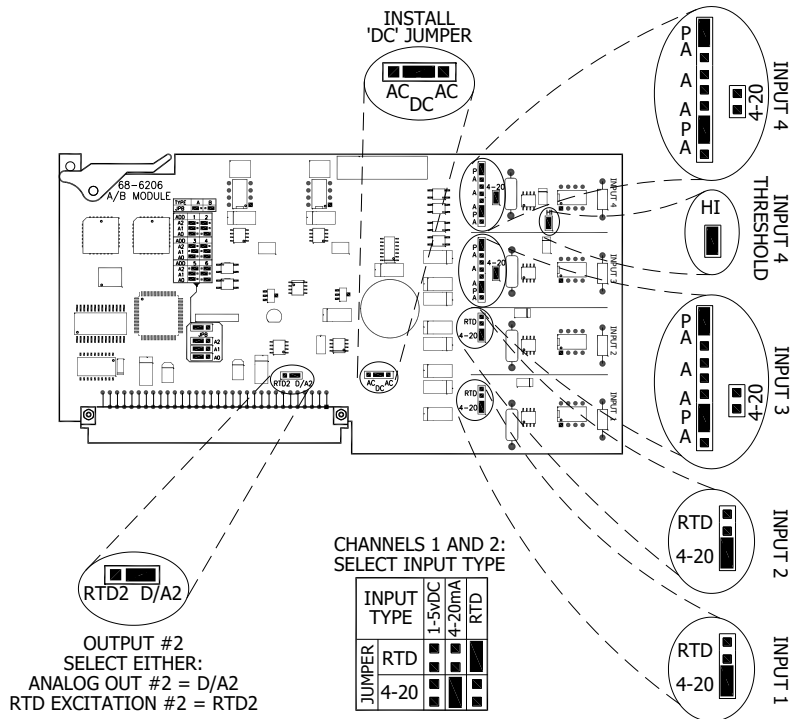

Figure A-3: A Module Pulse Jumper Settings

A.3.3 B Module Process Input Type – Pulse

The B module (or E/D module) is required when connecting to digital densitometers. With the B module, Analog Output #2 is never available, because the periodic time function uses the internal timer counter that is normally used to generate the second analog output.

To configure a B module for Pulse Inputs, set the jumpers according to these instructions.

Configure Inputs 1 and 2 for one of three analog signal types:

- For 1-5 VDC Input, remove both RTD and 4-20 jumpers.
- For 4-20 mA Input, install the 4-20 jumper.
- For RTD Input, install the RTD jumper.

Configure Input 3 for pulse signal types:

- Remove all four “A” jumpers, and install the two “P” jumpers.
- Remove the 4-20 jumper.

Configure Input 4 for pulse signal types:

- Remove all four “A” jumpers, and install the two “P” jumpers.
- Signal coupling is instrument dependent.
 - For AC coupled, install the two AC jumpers.
 - For DC coupled, install the DC jumper.
- Signal threshold is instrument dependent:
 - For a 1.5v threshold, remove the HI jumper.
 - For a 3.5v threshold, install the HI jumper.
- Remove the 4-20 jumper.

Refer to Figure A-4 for default input and output jumper settings: Inputs Ch1 = 4-20mA, Ch2 = 4-20mA, Ch3 = 4-20mA, Ch4 = AC coupled Pulse and Output Ch2 = RTD2.

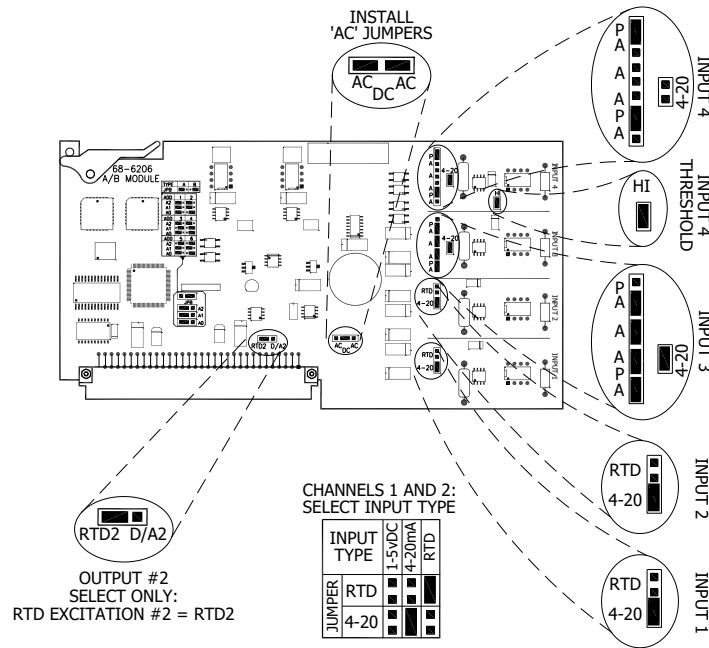

Figure A-4: B Module Jumper Settings

A.4 E/D Process Module

The E/D module is configured for either an E/D module or an E module by positioning the module TYPE jumper (JPD) in either the E/D or E position.

Each E/D or E module requires a specific address of 1 through 6. Position the jumpers address (MOD) for A0, A1 and A2 as indicated in the jumper tables located on the PCB. There are 4 process Input Channels.

The E module provides pulse interpolation and double chronometry timers to provide Level A pulse fidelity checking on Channels 3 or 4 to support small volume proving. This module also has a Detector Switch Input.

Channels 1 and 2 can accept:

- Analog input voltages (1-5 VDC)
- Current inputs (4-20mA) converted to 1-5 VDC by installing the 4-20 jumper
- Low level RTD input signals (0.20 - 0.55 VDC) by installing the RTD jumper, which increases the signal input by a factor of 10X

Channels 3 and 4 can be configured for flowmeter pulses or densitometer frequency signals. They can be configured for AC or DC signal coupling. Each input threshold can be adjusted for 1.5 or 3.5 Vpp, which makes it suitable for interfacing to Solartron type densitometers.

A.5 E/D Module Setup

Configure the E/D module as either an E/D module or E module by positioning the TYPE jumper (JPD) as indicated in Figure A-5.

Assign a unique address to each E/D or E module installed into the OMNI flow computer by positioning the jumper's address (MOD) as indicated in Figure A-5.

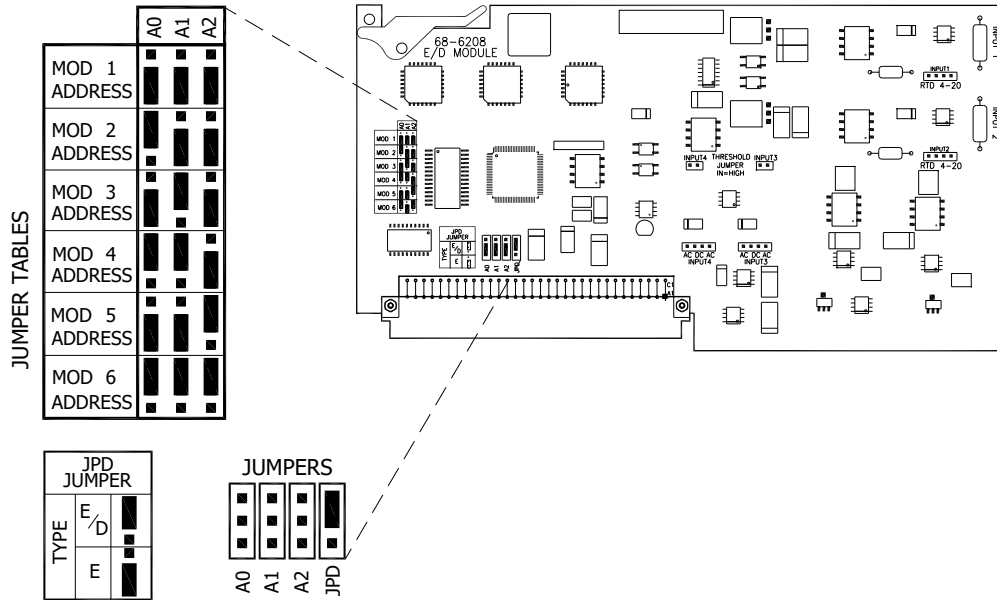

Figure A-5: E/D Module Type and Address Jumpers

A.5.1 E/D Module Process Inputs

To configure the E/D module Process Inputs, set the jumpers according to these instructions.

Configure Inputs 1 and 2 for one of three analog signal types:

- For 1-5 VDC Input, remove both RTD and 4-20 jumpers.
- For 4-20 mA Input, install the 4-20 jumper.
- For RTD Input, install the RTD jumper.

Configure Inputs 3 and 4 for pulse input type:

- Signal coupling is instrument dependent:
 - For AC coupled, install the two AC jumpers.
 - For DC coupled, install the DC jumper.
- Signal threshold is instrument dependent:
 - For a 1.5v threshold, remove the HI jumper.
 - For a 3.5v threshold, install the HI jumper.

Refer to Figure A-6 for default input jumper settings: Inputs Ch1 = 4-20mA, Ch2 = 4-20mA, Ch3 = AC coupled Pulse, Low threshold, and Ch4 = AC coupled Pulse, Low threshold.

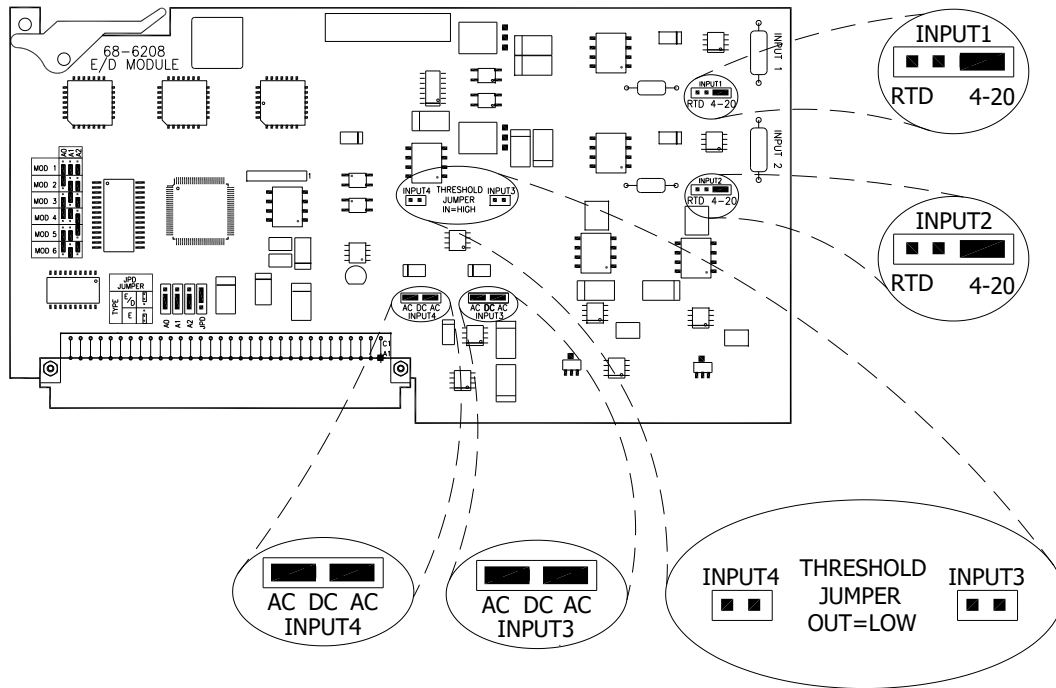

Figure A-6: E/D Module Jumper Settings

A.5.2 E Module Process Input

To configure the E module Process Inputs, set the jumpers according to these instructions.

Configure Inputs 1 and 2 for one of three analog signal types:

- For 1-5 VDC Input, remove both RTD and 4-20 jumpers.
- For 4-20 mA Input, install the 4-20 jumper.
- For RTD Input, install the RTD jumper.

Configure Inputs 3 and 4 for pulse input type:

- Signal coupling is instrument dependent:
 - For AC coupled, install the two AC jumpers.
 - For DC coupled, install the DC jumper.
- Signal threshold is instrument dependent:
 - For a 1.5v threshold, remove the HI jumper.
 - For a 3.5v threshold, install the HI jumper.

Refer to Figure A-7 for default input jumper settings: Inputs Ch1 = 4-20mA, Ch2 = 4-20mA, Ch3 = DC coupled Pulse, HI threshold, and Ch4 = DC coupled Pulse, Hi threshold.

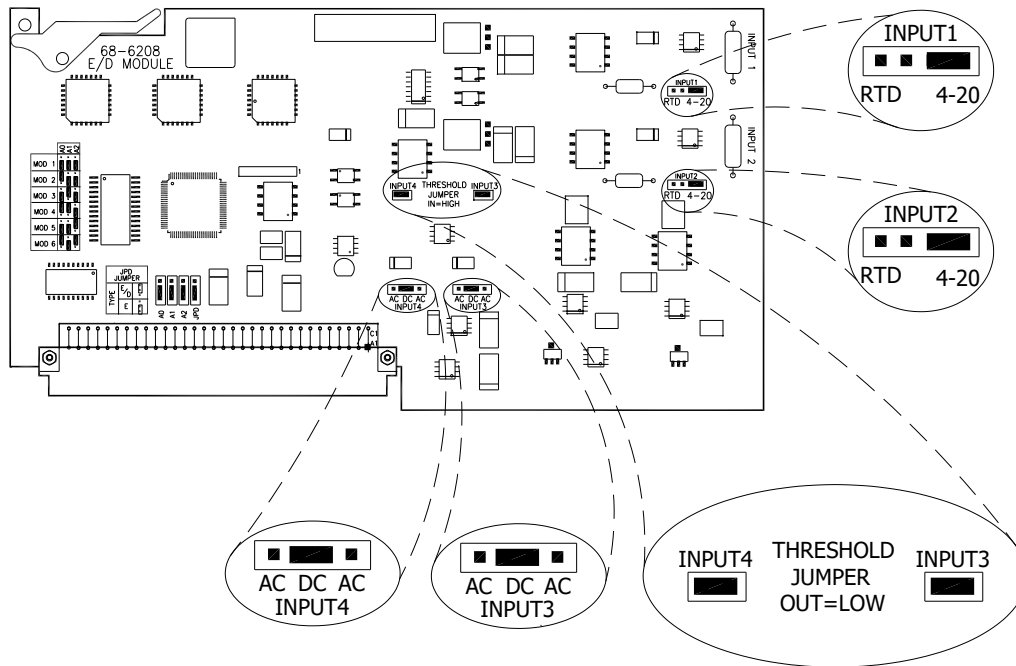

Figure A-7: E Module Jumper Settings

A.6 HART HT and HM Modules

The HART module is shipped as one of two: a 68-6207-HT or 68-6207-HM. The HT option is for use in point-to-point systems. The HM option can be used in point-to-point, multi-drop, or multi-variable mode systems.

For both option types, the HART module provides the following:

- Four independent HART FSK networks
- Two 4-20 mA Analog Outputs
- Maximum of six modules per OMNI 7000
- Point-to-point transmitter connections with the HT option
- Multi-drop and multi-variable transmitter connections with the HM option
- Four devices per network in multi-drop mode

A.7 HART Module Setup

Assign a unique address to each module installed into the OMNI flow computer by positioning jumpers as indicated in Figure A-8.

Loop power for each HART network must be provided externally by using the OMNI 7000 +24 VDC terminals or an external power supply. Loop load resistors are provided on the module for convenience and can be selected as being OUT of circuit, 250 ohms, or 500 ohms. When in the OUT position, a load resistor from 250 ohms to 600 ohms must be provided externally.

Configure each Load Resistor as required for instrument installation as indicated in Figure A-8 (refer to Figure 3-32 through Figure 3-34 for wiring examples).

- OUT = Externally installed load resistor of 250Ω to 600Ω
- 250Ω = On-board load resistor is installed in the current loop.
- 500Ω = On-board load resistor is installed in the current loop.

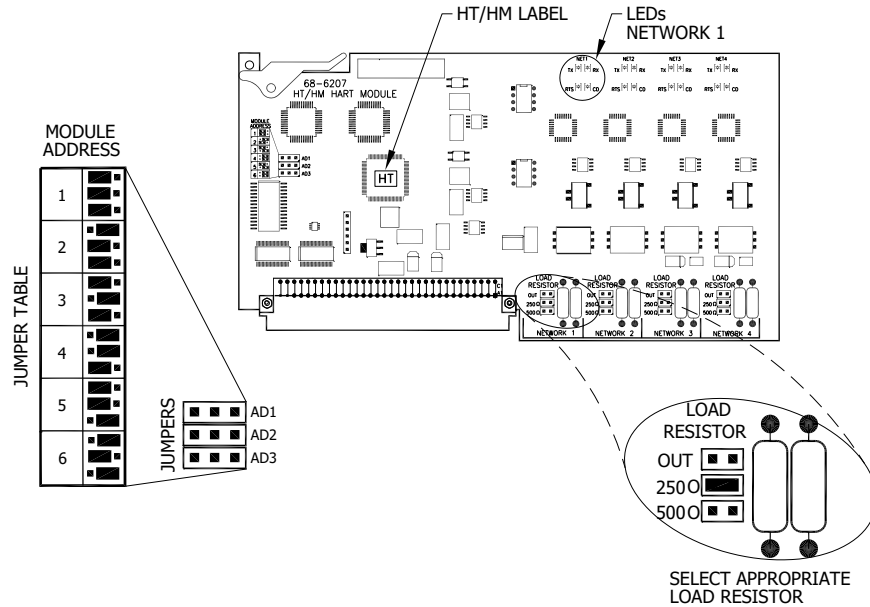

Figure A-8: HART Address and Load Resistor Jumpers

A.8 Digital I/O Terminal Board Setup

Each DT module requires a specific unique address of 1 through 3. Position the Address Selection Switches as indicated in the Address Selection table shown in Figure A-9.

- Set the COMM LINK TERMINATION Switch to the IN position:
 - If the DT module is the only Digital Terminal module connected to the flow computer
 - If the DT module is positioned at the end of the Comm Link bus. Refer to Digital Terminal Board #3 in Figure 3-20.
- Otherwise, set the switch to the OUT position.

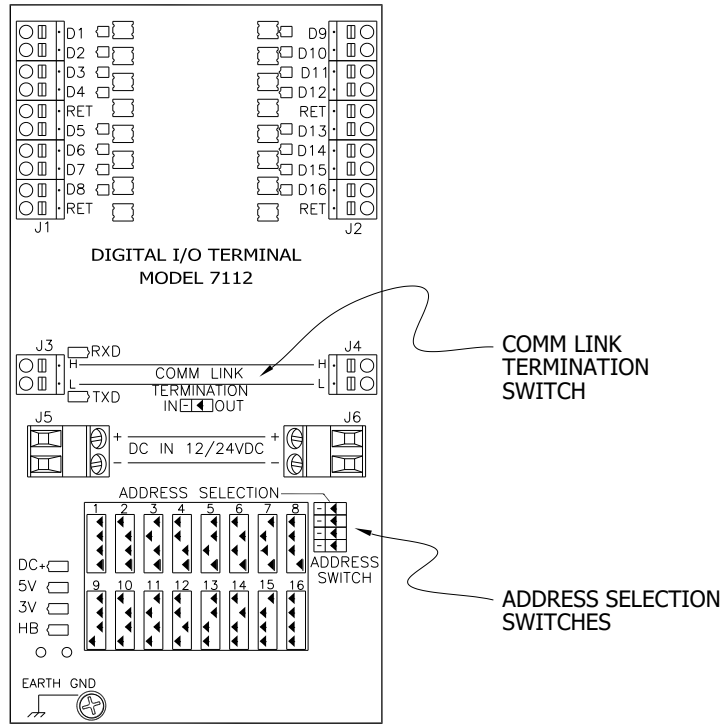
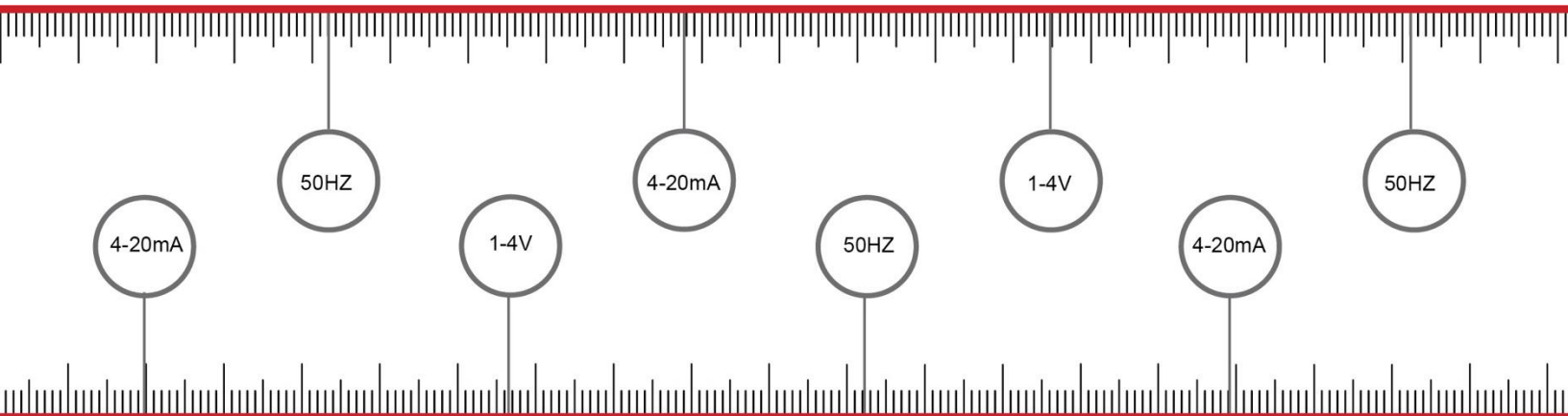

Figure A-9: DT Board Jumper Settings



The OMNI Flow logo, "OMNI", "OMNICOM" and "Measure the Difference", are registered trademarks of OMNI Flow Computers, Inc., in the United States and other countries. "OMNICONNECT" and "OMNIPANEL" are trademarks of OMNI Flow Computers, Inc., in the United States and other countries. All other trademarks are the property of their respective owners